



**NEHRU COLLEGE OF ENGINEERING AND RESEARCH CENTRE  
(NAAC Accredited)**

(Approved by AICTE, Affiliated to APJ Abdul Kalam Technological University, Kerala)



**1.2.2 Number of Add on /Certificate programs offered during the last five years**

**Academic Year : 2015- 2016**

**No. of Programmes: 12**

SI No	Department	Page No
1	<a href="#">Automobile Engineering</a>	2
2	<a href="#">Computer Science and Engineering</a>	62
3	<a href="#">Electrical and Electronics Engineering</a>	132
4	<a href="#">Mechanical Engineering</a>	227
5	<a href="#">Mechatronics Engineering</a>	330
6	<a href="#">MBA</a>	470
7	<a href="#">Electronics and Communication Engineering</a>	509
8	<a href="#">Master of Computer Applications</a>	581



**NEHRU COLLEGE OF ENGINEERING AND RESEARCH CENTRE  
(NAAC Accredited)**

(Approved by AICTE, Affiliated to APJ Abdul Kalam Technological University, Kerala)



# **Automobile Engineering**

NEHRU COLLEGE OF ENGINEERING AND RESEARCH CENTRE  
(Accredited by NAAC)  
PAMPADY, THIRUVILWAMALA, THRISSUR (DT) – 680588

NCERC/3128/F/AC/29/15

26.06.2015

**CIRCULAR**

It is informed that all the departments are directed to conduct the certificate courses and value added courses for the odd and even semesters of the Academic year 2015-16. The schedule for the above courses with details should be submitted to the office on or before 6<sup>th</sup> August 2015.



**Principal**

Copy to: All HoDs, for information and necessary action.

Circulate among Staffs

NCERC, Library.

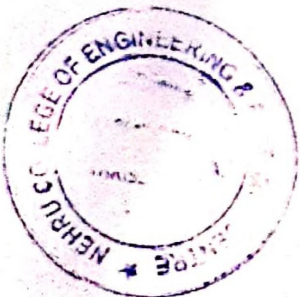

**PRINCIPAL**  
Nehru College of  
Engineering and Research Centre  
Pampady, Thiruvilwamala, Thrissur Dt  
Pin - 680 587 Kerala

# NEHRU COLLEGE OF ENGINEERING AND RESEARCH CENTRE

PAMPADY, THIRUVILWAMALA – 680 588

(ACCREDITED BY NAAC)







DEPARTMENT OF AUTOMOBILE ENGINEERING

Minutes of Meeting of Department Advisory Committee – 2015-16 – Odd Semester

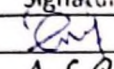
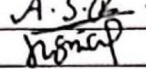
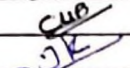
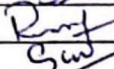
Date & Time:

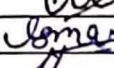
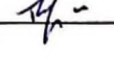
Meeting Facilitator: Head of the Department

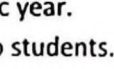
In Attendance:

S. No	Name	Signature
1	Vimal M N, Associate Professor	
2	Sagya Rajan, Associate Professor	
3	Senthil Kumar, Assistant Professor	
4	Subrahmannian AS, Assistant Professor	
5	Jayakrishnan S, Assistant Professor	
6	Ranjith, Assistant Professor	
7	Seena PS, Assistant Professor	
8	Jithin, Assistant Professor	
9	Deepak KP, Assistant Professor	
10	Shaik Usman Sha, Assistant Professor	
11	Rejumon R, Assistant Professor	

Absent: None

Meeting Agenda:

1. To discuss the certificate courses for the 2015-2016 academic year.
2. To identify the topics of the certificate courses for offering to students.
3. To select an interested faculty and allot the course.

Minutes of Meeting:

1. The meeting starts with a silent prayer.
2. HOD welcomed the entire teaching faculty for the meeting.
3. HOD asked for the willingness of the faculty to conduct the certificate course
4. Mr Shaik Usman Sha G has shown his willingness to take a certificate course on "Latest Technologies of modern passenger car familiarization, aggregates and system" in the academic year.
5. HOD asked Mr. Shaik Usman Sha G to prepare the syllabus for the topic and submit for approval.

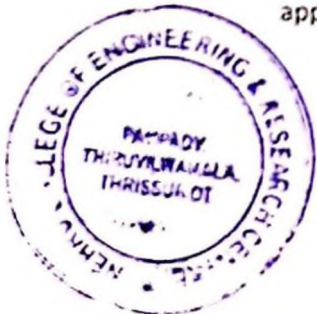

  
PRINCIPAL  
Nehru College of  
Engineering and Research Centre  
Pampady, Thiruvilwamala, Thrissur Dt  
Ph: 680 582 Kerala

6. HOD asked the department coordinator to make notice and publish it on the department notice board.
7. The meeting was concluded by 4 pm.

A.S.R.

Prepared by,

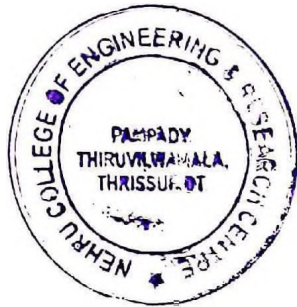

[Signature]

**PRINCIPAL**  
Nehru College of  
Engineering and Research Centre  
Pampady Thiruvilwamala Thrissur  
Pin 680 597 Kerala

**NEHRU COLLEGE OF ENGINEERING RESEARCH CENTRE**  
**PAMPADY, THIRUVILWAMALA - 680 588**  
**DEPARTMENT OF AUTOMOBILE ENGINEERING**  
**CERTIFICATE COURSE – 2015-2016 – ODD SEMESTER**

**LATEST TECHNOLOGIES OF MODERN PASSENGER CAR FAMILIARIZATION, AGGREGATES AND SYSTEM**  
**SYLLABUS**

CLASS	PARTICULARS
1	Introduction to automobile
2	Review of Auto basics
3	Automobile Working Cycle
4	Basic Terms such as HP, Torque, Sp Fuel consumption, Gradability
5	Wheel bases, Turning radius, Tracks, Road reactions, Vehicle stability etc
6	Introduction to Passenger Cars
7	Tata Passenger Car Types
8	Latest Car Models of competitors
9	Modern Car engines
10	Multipoint Injection Petrol engine, Common Rail Direct Injection Diesel engine
11	Modern Diesel Engines: FIP, ECU, Common rail injection Systems
12	Clutch
13	Transmission
14	Differential working /Functioning
15	Suspension , Independent suspension, Antiroll bars
16	Torsion bars , Stabilizers
17	Braking system
18	Vacuum Brakes, ABS
19	EBD
20	ESP/ECSs
21	Latest Technologies And Advancement Of Upcoming And Recent TATA
22	Motors Passenger Cars, EGR
23	SENSORS & SYSTEMS ADVANCEMENTS
24	EMMISSION CONTROL
25	EURO & BS SYSTEM & REQUIREMENT TO ACHIEVE
26	OTHER NEW SYSTEMS OF TATA MOTORS CARS
27	Physical Demonstration of Engine Assembly
28	Physical Demonstration of Clutch Assembly
29	Physical Demonstration of Gear Assembly
30	Physical Demonstration of Carburetor System

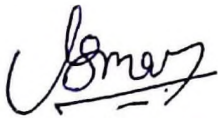

Program Coordinator



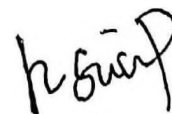

Head of the Department

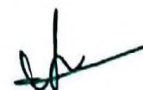

PRINCIPAL

Nehru College of  
 Engineering and Research Centre  
 Pampady, Thiruvilwamala, Thiruvananthapuram Dt  
 Pin - 680 597, Kerala

NEHRU COLLEGE OF ENGINEERING AND RESEARCH CENTRE  
PAMPADY, THIRUVILWAMALA - 680 588  
DEPARTMENT OF AUTOMOBILE ENGINEERING

NOTICE

As per the advice from the DAC meeting, it was decided to conduct the certificate course on "Latest Technologies of Modern Passenger Car Familiarization, Aggregates and System" which will be conducted by having 30 hours of contact classes from 4 pm to 5 pm in the odd semester of 2015-2016 academic year. Those who are interested to participate, enroll your name to your class advisor.



Head of the Department

To:

I, III, V, VII Semester Classroom - AUE  
Principal  
Academic Office  
Notice Board - AUE

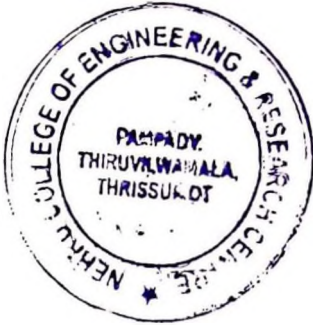

PRINCIPAL  
Nehru College of  
Engineering and Research Centre  
Pampady, Thiruvilwamala, Thrissur Dt  
Pin 680 597 Kerala

# NEHRU COLLEGE OF ENGINEERING AND RESEARCH CENTRE

PAMPADY, THIRUVILWAMALA - 680 588

DEPARTMENT OF AUTOMOBILE ENGINEERING

## ENROLLEMENT LIST OF CERTIFICATE COURSE - 2015-16 - ODD SEMESTER

Course Name : Latest Technologies of modern passenger car familiarization, aggregates and system

Sl No	Register Number	Student Name	Semester	Year
1	NCAMEAU001	Abhijith Na	VII	IV
2	NCAMEAU003	Abu Asad M	VII	IV
3	NCAMEAU004	Achengadan James Davis	VII	IV
4	NCAMEAU005	Ajith K	VII	IV
5	NCAMEAU007	Akshay Dileep	VII	IV
6	NCAMEAU008	Anoop M	VII	IV
7	NCAMEAU009	Aravind Yadav	VII	IV
8	NCAMEAU010	Arun C.r	VII	IV
9	NCAMEAU012	Arun S Varma	VII	IV
10	NCAMEAU013	Clins Thommy	VII	IV
11	NCAMEAU014	Devanand C.t	VII	IV
12	NCAMEAU015	Faes A.a	VII	IV
13	NCAMEAU017	Gokul Ajith	VII	IV
14	NCAMEAU018	Hiran K.h	VII	IV
15	NCAMEAU020	Kanchan B	VII	IV
16	NCAMEAU021	Krishna Das	VII	IV
17	NCAMEAU025	Midhun M	VII	IV
18	NCAMEAU026	Nair Vishnu Babu	VII	IV
19	NCAMEAU027	Nithin Raj	VII	IV
20	NCAMEAU028	Praveen Kumar N.k	VII	IV
21	NCAMEAU029	Rahul Mohan	VII	IV
22	NCAMEAU031	Rohith R Nath	VII	IV
23	NCAMEAU032	Sachin Ravi K.r	VII	IV
24	NCAMEAU033	Sajith N.s	VII	IV
25	NCAMEAU034	Sajith U Menon	VII	IV

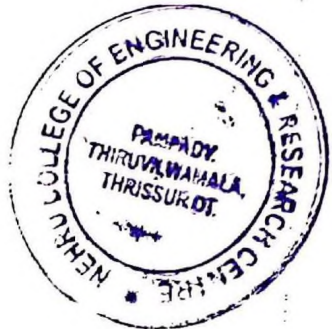

**PRINCIPAL**  
Nehru College of  
Engineering and Research Centre  
Pampady, Thiruvilwamala, Thrissur Dt  
Pin 680 597 Kerala.



26	NCAMEAU035	Shuhaib Rahman K	VII	IV
27	NCAMEAU036	Srijith R Nair	VII	IV
28	NCAMEAU037	Unais Rahman	VII	IV
29	NCAMEAU038	Vimal Dev I.p	VII	IV
30	NCANEAU001	Aakash P Mohan	V	III
31	NCANEAU002	Aaqil Roshan Shaik	V	III
32	NCANEAU004	Akhil M	V	III
33	NCANEAU005	Akshay A S	V	III
34	NCANEAU006	Akshay K	V	III
35	NCANEAU007	Amal Dev	V	III
36	NCANEAU008	Amal P	V	III
37	NCANEAU009	Ananthakrishnan C	V	III
38	NCANEAU010	Anson Ps	V	III
39	NCANEAU011	Anugrah P	V	III
40	NCANEAU012	Anushob O V	V	III
41	NCANEAU014	Aravind A	V	III
42	NCANEAU016	Arju P K	V	III
43	NCANEAU017	Ashiq .p.h	V	III
44	NCANEAU018	Ashish C G	V	III
45	NCANEAU019	Aswin Achuthan Palat	V	III
46	NCANEAU020	Azlan Ali	V	III
47	NCANEAU021	Carl Joy	V	III
48	NCANEAU022	Deepak K S	V	III
49	NCANEAU024	Gokul Raj	V	III
50	NCANEAU025	Greejith M.g	V	III
51	NCANEAU027	Harikrishna Yadav A.v	V	III
52	NCANEAU030	Jishnu A.h	V	III
53	NCANEAU031	Libin Andrews	V	III
54	NCANEAU032	Midhun Mohan	V	III
55	NCANEAU033	Mohammed Rusin Kafoor	V	III
56	NCANEAU037	Rahul M R	V	III

**PRINCIPAL**

Nehru College of  
Engineering and Research Centre  
Panipady Thiruvilwamala Thrissur Dt  
Pin - 680 597 Kerala

57	NCANEAU038	Rammohan C	V	III
58	NCANEAU039	Ranjith Kr	V	III
59	NCANEAU040	Raveen Krishna K	V	III
60	NCANEAU041	Rinoy Johnson	V	III
61	NCANEAU042	Sachin	V	III
62	NCANEAU043	Sahal Ali Ahmed	V	III
63	NCANEAU044	Sanad Thurakkal Puthan Purayil	V	III
64	NCANEAU045	Sanal Krishnan M	V	III
65	NCANEAU047	Sandeep K	V	III
66	NCANEAU048	Sandeep.m	V	III
67	NCANEAU049	Sanil A A	V	III
68	NCANEAU050	Santhanu Ajith	V	III
69	NCANEAU051	Sarath Chandran K.t	V	III
70	NCANEAU053	Sudin Sp	V	III
71	NCANEAU054	Syam P.s	V	III
72	NCANEAU055	Uday Harinarayanan	V	III
73	NCANEAU057	K A Vidyasagar	V	III
74	NCANEAU058	Vishnu Mohan	V	III
75	NCANEAU059	Kowshik V	V	III

*Principal*

Head of the Department



*Principal*

PRINCIPAL  
Nehru College of  
Engineering and Research Centre  
Thiruvananthapuram, Thiruvananthapuram  
Ph: 9447111111





NEHRU COLLEGE OF ENGINEERING AND RESEARCH CENTRE

PAMPADY, THIRUVILWAMALA - 680 588

DEPARTMENT OF AUTOMOBILE ENGINEERING

CERTIFICATE COURSE – 2015-2016 – ODD SEMESTER – EXAM

LATEST TECHNOLOGIES OF MODERN PASSENGER CAR FAMILIARIZATION, AGGREGATES AND SYSTEM

ANSWER KEY

Answer all the Questions

Max Marks: 50 Marks

- 1 The temperature indicating instrument in vehicles indicates the temperature of  
A) Engine piston      B) Engine cylinder      C) Lubricating oil      D) Jacket cooling water
- 2 Two general types of tyres are  
A) **Tube type and tubeless**      B) Solid and tubeless      C) Air and pneumatic      D) Split rim and drop centre
- 3 How many cells are used in a 12 volt car battery?  
A) 2      B) 4      C) **6**      D) 8
- 4 The motion of the cam is transferred to the valves through  
A) Pistons      B) **Rocker arms**      C) Camshaft pulley      D) Valve stems
- 5 The power actually developed inside the engine cylinder is called as  
A) **Indicated power**      B) Brake power      C) Frictional power      D) None of these
- 6 If the air-fuel mixture in a spark ignition engine is too rich, then air-fuel ratio is about  
A) 17:1      B) 15:1      C) 13:1      D) **10:1**
- 7 Petrol that detonates easily is called  
A) High octane petrol      B) **Low octane petrol**      C) Unleaded petrol      D) Blended fuel
- 8 The advantage of a tubeless tyre over tube type tyre is  
A) Slow air leakage      B) **Better fuel efficiency**      C) Less chances of running flat      D) **All of these**
- 9 In a single dry plate clutch, torsional vibrations are absorbed by  
A) **Coil springs known as torsional springs**      B) Cushion springs      C) Central hub      D) Clutch pedal
- 10 The battery is an electrochemical device, which means battery  
A) Makes chemicals by mechanical means      B) **Uses chemical action to provide electricity**      C) Has curved plates instead of flat plates      D) Does not use an electrolyte
- 11 An overinflated tyre will wear the tread most near the  
A) Edges      B) Corners      C) **Centre**      D) None of these
- 12 The calorific value of Diesel is about  
A) 36.5 MJ/kg      B) 38.5 MJ/kg      C) **42.5 MJ/kg**      D) 45.5 MJ/kg
- 13 The function of oil control rings is that it

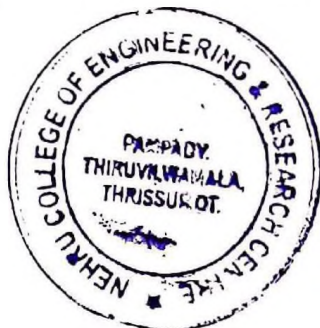

PRINCIPAL

Nehru College of  
Engineering and Research Centre  
Pampady Thiruvilwamala, Thrissur, Kerala  
Pin 680 597 Kerala

- A) Lubricates the cylinder wall by releasing oil from its hole
- B) Keeps the cylinder wall lubricated by holding oil in its channel
- C) Prevents engine oil from going into the combustion chamber and returns excess lubricating oil off the cylinder wall through the return holes in the piston to the oil pan
- D) Maintains a seal and prevents escape of burned gases and oil leakage
- 14 Two advantages of using helical gears rather than spur gears in a transmission system are
- A) Strength and cost
- B) Strength and less end thrust
- C) Noise level and strength
- D) Noise level and economy
- 15 The correct flow of power through the drive train is
- A) Engine drive shafts, clutch, main shaft, counter shaft, final driven gear, wheels
- B) Engine clutch, main shaft, counter shaft, final driven gear, drive shafts, wheels
- C) Engine clutch, counter shaft, main shaft, final driven gear, drive shafts, wheels
- D) Engine main shaft, counter shaft, clutch, final driven gear, drive shafts, wheels
- 16 The painting of automobiles is done to
- A) Prevent rust from growing on the body
- B) Improve its external appearance
- C) Retain the characteristics of steel for long
- D) All of these
- 17 The calorific value of petrol is about
- A) 36.5-38.5 MJ/kg
- B) 39.4-42.5 MJ/kg
- C) 42.7-43.5 MJ/kg
- D) 45.5-47 MJ/kg
- 18 The coefficient of friction for the clutch facing is approximately
- A) 0.1
- B) 0.4
- C) 0.8
- D) 1.2
- 19 The air resistance to a car at 20 kmph is R. The air resistance at 40 kmph will be
- A) R
- B) 2R
- C) 4R
- D) 4R<sup>2</sup>
- 20 The braking control type traction control system (TCS) generally operates in the speed range of
- A) Less than 20 kmph
- B) Less than 40 kmph
- C) Less than 60 kmph
- D) More than 60 kmph
- 21 The function of a first compression ring (top ring) is that it
- A) Increases the combustion temperature
- B) Creates swirl
- C) Maintains a seal and prevents the fuel leakage
- D) Maintains a seal and prevents escape of burned gases and loss of pressure in the combustion chamber
- 22 The component that connects the steering rack to the knuckles is
- A) Tie rod
- B) Sector gear
- C) Pivot
- D) Spline
- 23 The cetane number of a Diesel fuel is a measure of
- A) Volatility
- B) Viscosity
- C) Ignition quality
- D) Delay period
- 24 In petrol engines, during suction stroke, \_\_\_\_\_ is drawn in the cylinder

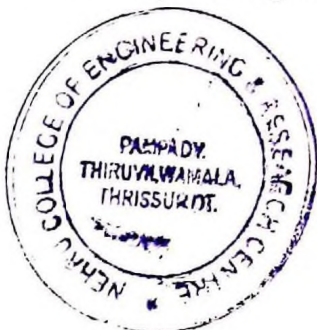

  
**PRINCIPAL**  
 Nehru College of  
 Engineering and Research Centre  
 Pamipady Thiruvilwamala, Thrissur Dt  
 Pin 680 597 Kerala

- 25      A) Air and fuel      B) Only fuel      C) Only air      D) None of these
- The main feature of Macpherson strut suspension is that
- A) The vertical size of the suspension can be made more compact      B) Non vertical external forces are supported by the suspension arms      C) The unsprung mass is lighter      D) The assembly is slightly more complicated in design

\*\*\*



A handwritten signature in black ink, appearing to be "JL".

**PRINCIPAL**  
Nehru College of  
Engineering and Research Centre  
Pampady Thiruvilwamala, Thirissur Dt  
Pin 680 597 Kerala

Student Name: Devanand C S

Register Number: NCAMEAU014.

36/50

18/25

NEHRU COLLEGE OF ENGINEERING AND RESEARCH CENTRE

PAMPADY, THIRUVILAVAMALA - 680 588

DEPARTMENT OF AUTOMOBILE ENGINEERING

CERTIFICATE COURSE – 2015-2016 – ODD SEMESTER – EXAM

**LATEST TECHNOLOGIES OF MODERN PASSENGER CAR FAMILIARIZATION, AGGREGATES AND SYSTEM**

Answer all the Questions and each question carry 2 marks

Max Marks: 50 Marks

- The temperature indicating instrument in vehicles indicates the temperature of
- 1 A) Engine piston B) Engine cylinder C) Lubricating oil  D) Jacket cooling water
- Two general types of tyres are
- 2 A)  Tube type and tubeless B) Solid and tubeless C) Air and pneumatic D) Split rim and drop centre
- How many cells are used in a 12 volt car battery?
- 3 A) 2 B) 4 C)  6 D) 8
- The motion of the cam is transferred to the valves through
- 4 A) Pistons B) Rocker arms C) Camshaft pulley  D) Valve stems
- The power actually developed inside the engine cylinder is called as
- 5 A)  Indicated power B) Brake power C) Frictional power D) None of these
- If the air-fuel mixture in a spark ignition engine is too rich, then air-fuel ratio is about
- 6 A) 17:1 B) 15:1 C)  13:1 D) 10:1
- Petrol that detonates easily is called
- 7 A) High octane petrol B)  Low octane petrol C) Unleaded petrol D) Blended fuel
- The advantage of a tubeless tyre over tube type tyre is
- 8 A) Slow air leakage B)  Better fuel efficiency C) Less chances of running flat D)  All of these
- In a single dry plate clutch, torsional vibrations are absorbed by
- 9 A) Coil springs known as torsional springs B)  Cushion springs C) Central hub D) Clutch pedal
- The battery is an electrochemical device, which means battery
- 10 A) Makes chemicals by mechanical means B) Uses chemical action to provide electricity C)  Has curved plates instead of flat plates D) Does not use an electrolyte
- An overinflated tyre will wear the tread most near the
- 11 A) Edges B) Corners C)  Centre D) None of these
- The calorific value of Diesel is about
- 12 A) 36.5 MJ/kg B) 38.5 MJ/kg C)  42.5 MJ/kg D) 45.5 MJ/kg
- 13 The function of oil control rings is that it

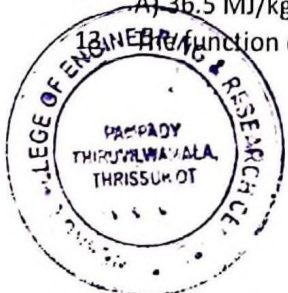

*[Signature]*  
PRINCIPAL  
Nehru College of  
Engineering and Research Centre  
Pampady Thiruvilavamala, Thrissur Dt  
Pin - 680 597 Kerala

Student Name:

Register Number:

- A) Lubricates the cylinder wall by releasing oil from its hole
- B) Keeps the cylinder wall lubricated by holding oil in its channel
- C)  Prevents engine oil from going into the combustion chamber and returns excess lubricating oil off the cylinder wall through the return holes in the piston to the oil pan
- D) Maintains a seal and prevents escape of burned gases and oil leakage
- 14 Two advantages of using helical gears rather than spur gears in a transmission system are
- A) Strength and cost
- B) Strength and less end thrust
- C)  Noise level and strength
- D) Noise level and economy
- 15 The correct flow of power through the drive train is
- A) Engine drive shafts, clutch, main shaft, counter shaft, final driven gear, wheels
- B)  Engine clutch, main shaft, counter shaft, final driven gear, drive shafts, wheels
- C) Engine clutch, counter shaft, main shaft, final driven gear, drive shafts, wheels
- D) Engine main shaft, counter shaft, clutch, final driven gear, drive shafts, wheels
- 16 The painting of automobiles is done to
- A) Prevent rust from growing on the body
- B)  Improve its external appearance
- C) Retain the characteristics of steel for long
- D)  All of these
- 17 The calorific value of petrol is about
- A) 36.5-38.5 MJ/kg
- B) 39.4-42.5 MJ/kg
- C) 42.7-43.5 MJ/kg
- D)  45.5-47 MJ/kg
- 18 The coefficient of friction for the clutch facing is approximately
- A) 0.1
- B)  0.4
- C) 0.8
- D) 1.2
- 19 The air resistance to a car at 20 kmph is R. The air resistance at 40 kmph will be
- A) R
- B) 2R
- C)  4R
- D) 4R<sup>2</sup>
- 20 The braking control type traction control system (TCS) generally operates in the speed range of
- A) Less than 20 kmph
- B) Less than 40 kmph
- C) Less than 60 kmph
- D)  More than 60 kmph
- 21 The function of a first compression ring (top ring) is that it
- A) Increases the combustion temperature
- B) Creates swirl
- C)  Maintains a seal and prevents the fuel leakage
- D) Maintains a seal and prevents escape of burned gases and loss of pressure in the combustion chamber
- 22 The component that connects the steering rack to the knuckles is
- A)  Tie rod
- B) Sector gear
- C) Pivot
- D) Spline

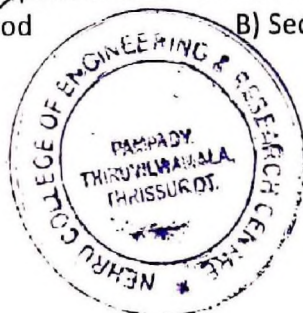

PRINCIPAL  
Nehru College of  
Engineering and Research Centre  
Pampady, Thiruvilwamala, Thrissur Dt  
Pin 680 597 Kerala

Student Name:

Register Number:

- 23 The cetane number of a Diesel fuel is a measure of  
A) Volatility                      B) Viscosity                      C) Ignition quality                       D) Delay period
- 24 In petrol engines, during suction stroke, \_\_\_\_\_ is drawn in the cylinder  
 A) Air and fuel                      B) Only fuel                      C) Only air                      D) None of these
- 25 The main feature of Macpherson strut suspension is that  
A) The vertical size of the suspension can be made more compact                       B) Non vertical external forces are supported by the suspension arms                      C) The unsprung mass is lighter                      D) The assembly is slightly more complicated in design

\*\*\*



PRINCIPAL  
Nehru College of  
Engineering and Research Centre  
Panipady, Thiruvithamala, Thiruvananthapuram Dt  
Pin: 680 597 Kerala

Student Name: Sachin Ravi K. R

Register Number: NCEMDEAU032

36/50 18/25

NEHRU COLLEGE OF ENGINEERING AND RESEARCH CENTRE

PAMPADY THIRUVILWAMALA - 680 588

DEPARTMENT OF AUTOMOBILE ENGINEERING

CERTIFICATE COURSE - 2015-2016 - ODD SEMESTER - EXAM

LATEST TECHNOLOGIES OF MODERN PASSENGER CAR FAMILIARIZATION, AGGREGATES AND SYSTEM

Answer all the Questions and each question carry 2 marks

Max Marks: 50 Marks

- The temperature indicating instrument in vehicles indicates the temperature of
- 1 A) Engine piston B) Engine cylinder C) Lubricating oil  D) Jacket cooling water
- Two general types of tyres are
- 2  A) Tube type and tubeless B) Solid and tubeless C) Air and pneumatic D) Split rim and drop centre
- How many cells are used in a 12 volt car battery?
- 3 A) 2  B) 4 C) 6 D) 8
- The motion of the cam is transferred to the valves through
- 4 A) Pistons  B) Rocker arms C) Camshaft pulley D) Valve stems
- The power actually developed inside the engine cylinder is called as
- 5  A) Indicated power B) Brake power C) Frictional power D) None of these
- If the air-fuel mixture in a spark ignition engine is too rich, then air-fuel ratio is about
- 6 A) 17:1 B) 15:1 C) 13:1  D) 10:1
- Petrol that detonates easily is called
- 7 A) High octane petrol B) Low octane petrol  C) Unleaded petrol D) Blended fuel
- The advantage of a tubeless tyre over tube type tyre is
- 8 A) Slow air leakage B) Better fuel efficiency C) Less chances of running flat  D) All of these
- In a single dry plate clutch, torsional vibrations are absorbed by
- 9  A) Coil springs known as torsional springs B) Cushion springs C) Central hub D) Clutch pedal
- The battery is an electrochemical device, which means battery
- 10 A) Makes chemicals by mechanical means  B) Uses chemical action to provide electricity C) Has curved plates instead of flat plates D) Does not use an electrolyte
- An overinflated tyre will wear the tread most near the
- 11 A) Edges B) Corners  C) Centre D) None of these
- The calorific value of Diesel is about
- 12 A) 36.5 MJ/kg B) 38.5 MJ/kg  C) 42.5 MJ/kg D) 45.5 MJ/kg
- 13 The function of oil control rings is that it

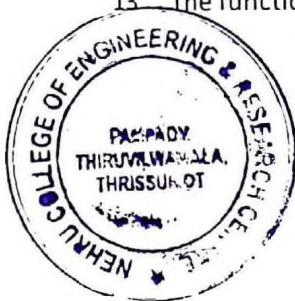

  
PRINCIPAL  
Nehru College of  
Engineering and Research Centre  
Pampady Thiruvilwamala, Thrissur Dt  
Pin 680 597 Kerala

Student Name:

Register Number:

- A) Lubricates the cylinder wall by releasing oil from its hole
- B) Keeps the cylinder wall lubricated by holding oil in its channel
- C) Prevents engine oil from going into the combustion chamber and returns excess lubricating oil off the cylinder wall through the return holes in the piston to the oil pan
- D) Maintains a seal and prevents escape of burned gases and oil leakage
- 14 Two advantages of using helical gears rather than spur gears in a transmission system are
- A) Strength and cost
- B) Strength and less end thrust
- C) Noise level and strength
- D) Noise level and economy
- 15 The correct flow of power through the drive train is
- A) Engine drive shafts, clutch, main shaft, counter shaft, final driven gear, wheels
- B) Engine clutch, main shaft, counter shaft, final driven gear, drive shafts, wheels
- C) Engine clutch, counter shaft, main shaft, final driven gear, drive shafts, wheels
- D) Engine main shaft, counter shaft, clutch, final driven gear, drive shafts, wheels
- 16 The painting of automobiles is done to
- A) Prevent rust from growing on the body
- B) Improve its external appearance
- C) Retain the characteristics of steel for long
- D) All of these
- 17 The calorific value of petrol is about
- A) 36.5-38.5 MJ/kg
- B) 39.4-42.5 MJ/kg
- C) 42.7-43.5 MJ/kg
- D) 45.5-47 MJ/kg
- 18 The coefficient of friction for the clutch facing is approximately
- A) 0.1
- B) 0.4
- C) 0.8
- D) 1.2
- 19 The air resistance to a car at 20 kmph is R. The air resistance at 40 kmph will be
- A) R
- B) 2R
- C) 4R
- D) 4R<sup>2</sup>
- 20 The braking control type traction control system (TCS) generally operates in the speed range of
- A) Less than 20 kmph
- B) Less than 40 kmph
- C) Less than 60 kmph
- D) More than 60 kmph
- 21 The function of a first compression ring (top ring) is that it
- A) Increases the combustion temperature
- B) Creates swirl
- C) Maintains a seal and prevents the fuel leakage
- D) Maintains a seal and prevents escape of burned gases and loss of pressure in the combustion chamber
- 22 The component that connects the steering rack to the knuckles is
- A) Tie rod
- B) Sector gear
- C) Pivot
- D) Spline
- 23 The cetane number of a Diesel fuel is a measure of
- A) Volatility
- B) Viscosity
- C) Ignition quality
- D) Delay period

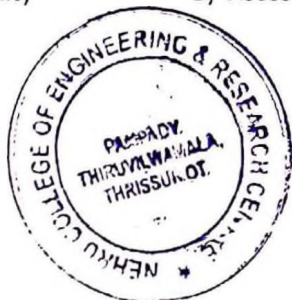

  
PRINCIPAL  
Nehru College of  
Engineering and Research Centre  
Pampady Thiruvilwamala Thrikkulam  
Pin 680 597 Kerala

Student Name:

Register Number:

- 24 In petrol engines, during suction stroke, \_\_\_\_\_ is drawn in the cylinder  
A) Air and fuel      B) Only fuel      C) Only air      D) None of these
- 25 The main feature of Macpherson strut suspension is that  
A) The vertical size of the suspension can be made more compact      B) Non vertical external forces are supported by the suspension arms      C) The unsprung mass is lighter      D) The assembly is slightly more complicated in design

\*\*\*



  
**PRINCIPAL**  
Nehru College of  
Engineering and Research Centre  
Panpady Thiruvilwamala Thirissur Dist.  
Pin 680 597 Kerala

Student Name: Arun S Varma

Register Number: NCEMEA012

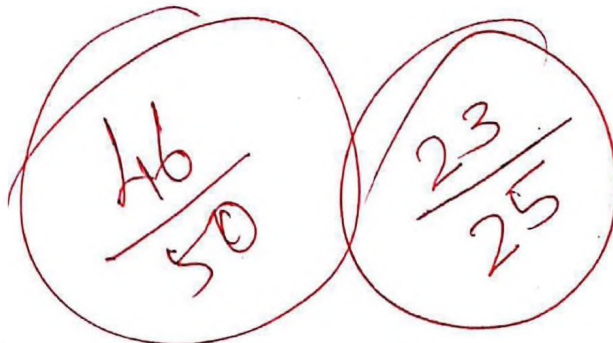

NEHRU COLLEGE OF ENGINEERING AND RESEARCH CENTRE

PAMPADY, THIRUVILWAMALA - 680 588

DEPARTMENT OF AUTOMOBILE ENGINEERING

CERTIFICATE COURSE – 2015-2016 – ODD SEMESTER – EXAM

LATEST TECHNOLOGIES OF MODERN PASSENGER CAR FAMILIARIZATION, AGGREGATES AND SYSTEM

Answer all the Questions and each question carry 2 marks

Max Marks: 50 Marks

- The temperature indicating instrument in vehicles indicates the temperature of
- 1 A) Engine piston B) Engine cylinder C) Lubricating oil  D) Jacket cooling water
- Two general types of tyres are
- 2  A) Tube type and tubeless B) Solid and tubeless C) Air and pneumatic D) Split rim and drop centre
- How many cells are used in a 12 volt car battery?
- 3 A) 2 B) 4  C) 6 D) 8
- The motion of the cam is transferred to the valves through
- 4 A) Pistons  B) Rocker arms C) Camshaft pulley D) Valve stems
- The power actually developed inside the engine cylinder is called as
- 5  A) Indicated power B) Brake power C) Frictional power D) None of these
- If the air-fuel mixture in a spark ignition engine is too rich, then air-fuel ratio is about
- 6 A) 17:1 B) 15:1 C) 13:1  D) 10:1
- Petrol that detonates easily is called
- 7 A) High octane petrol  B) Low octane petrol C) Unleaded petrol D) Blended fuel
- The advantage of a tubeless tyre over tube type tyre is
- 8 A) Slow air leakage B) Better fuel efficiency  C) Less chances of running flat D) All of these
- In a single dry plate clutch, torsional vibrations are absorbed by
- 9  A) Coil springs known as torsional springs B) Cushion springs C) Central hub D) Clutch pedal
- The battery is an electrochemical device, which means battery
- 10 A) Makes chemicals by mechanical means  B) Uses chemical action to provide electricity C) Has curved plates instead of flat plates D) Does not use an electrolyte
- An overinflated tyre will wear the tread most near the
- 11 A) Edges B) Corners  C) Centre D) None of these
- The calorific value of Diesel is about
- 12 A) 36.5 MJ/kg B) 38.5 MJ/kg C) 42.5 MJ/kg  D) 45.5 MJ/kg
- 13 The function of oil control rings is that it

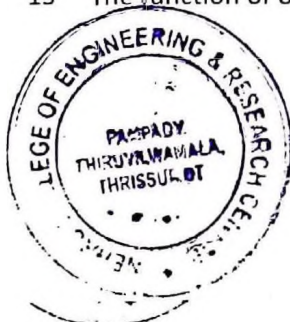

PRINCIPAL  
Nehru College of  
Engineering and Research Centre  
Pampady Thiruvilwamala Thrissur 01  
Pin 680 597 Kerala

Student Name:

Register Number:

- A) Lubricates the cylinder wall by releasing oil from its hole
- B) Keeps the cylinder wall lubricated by holding oil in its channel
- C) Prevents engine oil from going into the combustion chamber and returns excess lubricating oil off the cylinder wall through the return holes in the piston to the oil pan
- D) Maintains a seal and prevents escape of burned gases and oil leakage
- 14 Two advantages of using helical gears rather than spur gears in a transmission system are
- A) Strength and cost
- B) Strength and less end thrust
- C) Noise level and strength
- D) Noise level and economy
- 15 The correct flow of power through the drive train is
- A) Engine drive shafts, clutch, main shaft, counter shaft, final driven gear, wheels
- B) Engine clutch, main shaft, counter shaft, final driven gear, drive shafts, wheels
- C) Engine clutch, counter shaft, main shaft, final driven gear, drive shafts, wheels
- D) Engine main shaft, counter shaft, clutch, final driven gear, drive shafts, wheels
- 16 The painting of automobiles is done to
- A) Prevent rust from growing on the body
- B) Improve its external appearance
- C) Retain the characteristics of steel for long
- D) All of these
- 17 The calorific value of petrol is about
- A) 36.5-38.5 MJ/kg
- B) 39.4-42.5 MJ/kg
- C) 42.7-43.5 MJ/kg
- D) 45.5-47 MJ/kg
- 18 The coefficient of friction for the clutch facing is approximately
- A) 0.1
- B) 0.4
- C) 0.8
- D) 1.2
- 19 The air resistance to a car at 20 kmph is R. The air resistance at 40 kmph will be
- A) R
- B) 2R
- C) 4R
- D) 4R<sup>2</sup>
- 20 The braking control type traction control system (TCS) generally operates in the speed range of
- A) Less than 20 kmph
- B) Less than 40 kmph
- C) Less than 60 kmph
- D) More than 60 kmph
- 21 The function of a first compression ring (top ring) is that it
- A) Increases the combustion temperature
- B) Creates swirl
- C) Maintains a seal and prevents the fuel leakage
- D) Maintains a seal and prevents escape of burned gases and loss of pressure in the combustion chamber
- 22 The component that connects the steering rack to the knuckles is
- A) Tie rod
- B) Sector gear
- C) Pivot
- D) Spline



PRINCIPAL  
Nehru College of  
Engineering and Research Centre  
Pamplady Thiruvilwamala, Thrissur Dt  
Pin: 680 597 Kerala

Student Name:

Register Number:

- 23 The cetane number of a Diesel fuel is a measure of  
A) Volatility B) Viscosity C) Ignition quality D) Delay period
- 24 In petrol engines, during suction stroke, \_\_\_\_\_ is drawn in the cylinder  
A) Air and fuel B) Only fuel C) Only air D) None of these
- 25 The main feature of Macpherson strut suspension is that  
A) The vertical size of the suspension can be made more compact  
B) Non vertical external forces are supported by the suspension arms  
C) The unsprung mass is lighter  
D) The assembly is slightly more complicated in design

\*\*\*



  
**PRINCIPAL**  
Nehru College of  
Engineering and Research Centre  
Panipady Thiruvilwamala, Thirissur Dt  
Pin 680 597 Kerala

# NEHRU COLLEGE OF ENGINEERING AND RESEARCH CENTRE

PAMPADY, THIRUVILWAMALA - 680 588

## DEPARTMENT OF AUTOMOBILE ENGINEERING

### MARK LIST OF CERTIFICATE COURSE - 2015-16 - ODD SEMESTER

Course Name : Latest Technologies of modern passenger car familiarization, aggregates and system

Sl No	Register Number	Student Name	Semester	Year	Marks
1	NCAMEAU001	Abhijith Na	VII	IV	42
2	NCAMEAU003	Abu Asad M	VII	IV	38
3	NCAMEAU004	Achengadan James Davis	VII	IV	32
4	NCAMEAU005	Ajith K	VII	IV	36
5	NCAMEAU007	Akshay Dileep	VII	IV	32
6	NCAMEAU008	Anoop M	VII	IV	34
7	NCAMEAU009	Aravind Yadav	VII	IV	38
8	NCAMEAU010	Arun C.r	VII	IV	34
9	NCAMEAU012	Arun S Varma	VII	IV	46
10	NCAMEAU013	Clins Thommy	VII	IV	34
11	NCAMEAU014	Devanand C.t	VII	IV	36
12	NCAMEAU015	Faes A.a	VII	IV	38
13	NCAMEAU017	Gokul Ajith	VII	IV	36
14	NCAMEAU018	Hiran K.h	VII	IV	34
15	NCAMEAU020	Kanchan B	VII	IV	38
16	NCAMEAU021	Krishna Das	VII	IV	42
17	NCAMEAU025	Midhun M	VII	IV	42
18	NCAMEAU026	Nair Vishnu Babu	VII	IV	40
19	NCAMEAU027	Nithin Raj	VII	IV	34
20	NCAMEAU028	Praveen Kumar N.k	VII	IV	36
21	NCAMEAU029	Rahul Mohan	VII	IV	32
22	NCAMEAU031	Rohith R Nath	VII	IV	30
23	NCAMEAU032	Sachin Ravi K.r	VII	IV	36
24	NCAMEAU033	Sajith N.s	VII	IV	32
25	NCAMEAU034	Sajith U Menon	VII	IV	36
26	NCAMEAU035	Shuhaib Rahman K	VII	IV	34
27	NCAMEAU036	Srijith R Nair	VII	IV	32
28	NCAMEAU037	Unais Rahman	VII	IV	34
29	NCAMEAU038	Vimal Dev I.p	VII	IV	36
30	NCANEAU001	Aakash P Mohan	V	III	32
31	NCANEAU002	Aaqil Roshan Shaik	V	III	32
32	NCANEAU004	Akhil M	V	III	36
33	NCANEAU005	Akshay A S	V	III	38
34	NCANEAU006	Akshay K	V	III	36
35	NCANEAU007	Amal Dev	V	III	34
36	NCANEAU008	Amal P	V	III	36
37	NCANEAU009	Ananthakrishnan C	V	III	38
38	NCANEAU010	Anson Ps	V	III	32

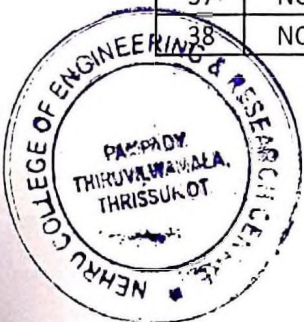

PRINCIPAL  
Nehru College of  
Engineering and Research Centre  
Pampady Thiruvilwamala, Thirissur Dt  
Pin 680 597 Kerala

Sl No	Register Number	Student Name	Semester	Year	Marks
39	NCANEAU011	Anugrah P	V	III	42
40	NCANEAU012	Anushob O V	V	III	44
41	NCANEAU014	Aravind A	V	III	42
42	NCANEAU016	Arju P K	V	III	42
43	NCANEAU017	Ashiq .p.h	V	III	34
44	NCANEAU018	Ashish C G	V	III	42
45	NCANEAU019	Aswin Achuthan Palat	V	III	38
46	NCANEAU020	Azlan Ali	V	III	36
47	NCANEAU021	Carl Joy	V	III	32
48	NCANEAU022	Deepak K S	V	III	34
49	NCANEAU024	Gokul Raj	V	III	32
50	NCANEAU025	Greejith M.g	V	III	34
51	NCANEAU027	Harikrishna Yadav A.v	V	III	36
52	NCANEAU030	Jishnu A.h	V	III	38
53	NCANEAU031	Libin Andrews	V	III	32
54	NCANEAU032	Midhun Mohan	V	III	34
55	NCANEAU033	Mohammed Rusin Kafoor	V	III	32
56	NCANEAU037	Rahul M R	V	III	34
57	NCANEAU038	Rammohan C	V	III	34
58	NCANEAU039	Ranjith Kr	V	III	36
59	NCANEAU040	Raveen Krishna K	V	III	42
60	NCANEAU041	Rinoy Johnson	V	III	36
61	NCANEAU042	Sachin	V	III	26
62	NCANEAU043	Sahal Ali Ahmed	V	III	38
63	NCANEAU044	Sanad Thurakkal Puthan Purayil	V	III	38
64	NCANEAU045	Sanal Krishnan M	V	III	22
65	NCANEAU047	Sandeep K	V	III	24
66	NCANEAU048	Sandeep.m	V	III	26
67	NCANEAU049	Sanil A A	V	III	32
68	NCANEAU050	Santhanu Ajith	V	III	36
69	NCANEAU051	Sarath Chandran K.t	V	III	28
70	NCANEAU053	Sudin Sp	V	III	30
71	NCANEAU054	Syam P.s	V	III	32
72	NCANEAU055	Uday Harinarayanan	V	III	34
73	NCANEAU057	K A Vidyasagar	V	III	36
74	NCANEAU058	Vishnu Mohan	V	III	32
75	NCANEAU059	Kowshik V	V	III	30



*J. S. S. S.*  
Head of the Department

*Ch*  
PRINCIPAL  
Nehru College of  
Engineering and Research Centre  
Pampady Thiruvilwamala, Thiruvananthapuram Dt  
Pin - 6e0 597 Kerala

Date: 3 / 8 / 2015

From

Shaik Usman Sha G,  
Course Coordinator,  
Department of Automobile Engineering,  
Nehru College of Engineering and Research Centre  
Pampady, Thiruvilwamala - 680 588.

To

The Principal,  
Nehru College of Engineering and Research Centre  
Pampady, Thiruvilwamala - 680 588.

Through: HOD, Department of Automobile Engineering

Respected Sir,

SUB: Request for conducting Certificate Course for the odd semester of 2015 - 2016 Academic Year - reg

As per the circular number NCERC/3128/F/AC/29/15 on 26.06.2015, I may request your permission to conduct the certificate course for the odd semester of the 2015-2016 academic year. The syllabus and lecture plan is attached herewith for your perusal.

Details of Course certificate:

Academic Year	Semester	Topic	Time	No of Hours
2015 - 2016	ODD	Latest Technologies of modern passenger car familiarization, aggregates and system	4 pm - 5 pm	30

Kindly do the needful. Thank you.

Yours faithfully,

Shaik Usman Sha G,  
Assistant Professor – AUE.

*Forwarded To Principal*

*3/8/15*

*As per*

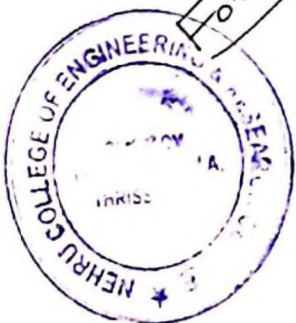

PRINCIPAL  
Nehru College of  
Engineering and Research Centre  
Pampady, Thiruvilwamala, Thiruvananthapuram  
Pin - 680 588 Kerala

# ABOUT US

Nehru College of Engineering and Research Centre(NCERC), situated on the Bank of the river Nila, is a premier Engineering college that has pioneered engineering education, research and training in the private sector. Established in 2002 by the founder chairman Shri P.K. Das, NCERC is committed to impart world class quality education in engineering and research. Dedicated to the service in the realm of technical education in Kerala, it is an ISO 9001:2015 certified institution, approved by All India Council for Technical Education (AICTE), affiliated to A P J Abdul Kalam Technological University(KTU) and is accredited by National Assessment and Accreditation Council (NAAC).



[www.ncerc.ac.in](http://www.ncerc.ac.in)  
PH: 04884 282070, 284000



NEHRU COLLEGE OF ENGINEERING AND RESEARCH CENTRE, PAMPADY THRISSUR.

PRESENTS

A COURSE ON

*Latest Technologies of modern passenger car familiarization, aggregates and system*

DURING 2015-2016 ODD SEMESTER

Cordinator

Mr. Shaik Usman Sha G

DEPARTMENT OF AUTOMOBILE ENGINEERING



PRINCIPAL

Nehru College of Engineering and Research Centre  
Pampady, Thrissur, Kerala  
686 012, India

## ABOUT THE COURSE

- This course will provide the college students a base to automotive technology.
- Students will learn about each and every driving systems involved in automation and get better understanding and grip on its application.
- Students will be learning the basics of each and every automotive part along with the physical demonstration of many automotive parts, so that they have the insight of the full working mechanism involved in it.
- These projects focus on the application and use of technology rather than their internal working so that a person can grasp the concepts well.
- This is more practically oriented course which is provided to give the insight of the real mechanism involved in different automotive parts.



# Latest Technologies of modern passenger car familiarization , aggregates and system

## COURSE DETAILS

### COURSE COORDINATOR



Mr. Shaik Usman Sha G  
Assistant Professor,  
Departement of Automobile Engineering

### CONTACT

Email: [shaikusmansha@ncerc.ac.in](mailto:shaikusmansha@ncerc.ac.in)

Phone: 9447365475

PRINCIPAL  
Nehru College of  
Engineering and Research Centre  
Thiruvananthapuram



**NEHRU COLLEGE OF ENGINEERING AND RESEARCH CENTRE**  
**THRISSUR - 680 588**

**COURSE COMPLETION CERTIFICATE**

Is presented to  
Clins Thommy

For successfully completing the course on "**Latest Technologies of modern passenger car familiarization, aggregates and system**" organised by Department of Automobile Engineering, Nehru College of Engineering and Research Centre, Thrissur during odd semesters of 2015-2016 academic year.

Program Coordinator

HoD

**PRINCIPAL**  
Nehru College of Engineering and Research Centre  
Thrissur - 680 588





NEHRU COLLEGE OF ENGINEERING AND RESEARCH CENTRE  
THRISSUR - 680 588

COURSE COMPLETION CERTIFICATE

Is presented to  
Syam P.S

For successfully completing the course on "**Latest Technologies of modern passenger car familiarization, aggregates and system**" organised by Department of Automobile Engineering, Nehru College of Engineering and Research Centre, Thrissur during odd semesters of 2015-2016 academic year.

Program Coordinator

HoD

PRINCIPAL  
Nehru College of  
Engineering and Research Ce  
Panipady, Thrissur, Kerala, India  
Ph: 0487-2522000



NEHRU COLLEGE OF ENGINEERING AND RESEARCH CENTRE  
THRISSUR - 680 588

COURSE COMPLETION CERTIFICATE

Is presented to  
Praveen Kumar N.K

For successfully completing the course on "**Latest Technologies of modern passenger car familiarization, aggregates and system**" organised by Department of Automobile Engineering, Nehru College of Engineering and Research Centre, Thrissur during odd semesters of 2015-2016 academic year.

Program Coordinator

HoD



PRINCIPAL  
Nehru College of  
Engineering and Research Centre  
Panampilly, Thrissur - 680 588  
Ph: 680 588 5888

# NEHRU COLLEGE OF ENGINEERING AND RESEARCH CENTRE

PAMPADY, THIRUVILWAMALA – 680 588

(ACCREDITED BY NAAC)







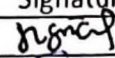

DEPARTMENT OF AUTOMOBILE ENGINEERING

Minutes of Meeting of Department Advisory Committee – 2015-16 – Even Semester

Date & Time:

Meeting Facilitator: Head of the Department

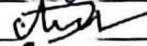
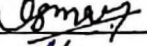
In Attendance:

S. No	Name	Signature
1	Senthil Kumar, Assistant Professor	
2	Vimal M N, Associate Professor	
3	Subrahmannian AS, Assistant Professor	
4	Jayakrishnan S, Assistant Professor	
5	Ranjith, Assistant Professor	
6	Seena PS, Assistant Professor	
7	Jithin, Assistant Professor	
8	Deepak KP, Assistant Professor	
9	Shaik Usman Sha, Assistant Professor	
10	Rejumon R, Assistant Professor	

Absent: None

Meeting Agenda:

1. To discuss the certificate courses for the 2015-2016 academic year.
2. To identify the topics of the certificate courses for offering to students.
3. To select an interested faculty and allot the course.

Minutes of Meeting:

1. The meeting starts with a silent prayer.
2. HOD welcomed the entire teaching faculty for the meeting.
3. HOD asked for the willingness of the faculty to conduct the certificate course
4. Mr Deepak K P has shown his willingness to take a certificate course on "Proposal for automotive workshop on automobile basics + advanced system study "in the academic year.
5. HOD asked Mr Deepak K P to prepare the syllabus for the topic and submit for approval.



  
PRINCIPAL  
Nehru College of  
Engineering and Research Centre  
Pampady, Thiruvilwamala, Thrissur Dt  
Pin 680 597 Kerala

6. HOD asked the department coordinator to make notice and publish it on the department notice board.
7. The meeting was concluded by 4 pm.

Prepared by,

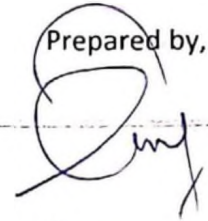

(VIMAL U N)



PRINCIPAL  
Nehru College of  
Engineering and Research Centre  
Panipady Thiruvilwamala, Thrikkur OT,  
Pin - 680 597 Kerala

NEHRU COLLEGE OF ENGINEERING RESEARCH CENTRE

PAMPADY, THIRUVILWAMALA – 680 588

DEPARTMENT OF AUTOMOBILE ENGINEERING

CERTIFICATE COURSE – 2015-2016 – EVEN SEMESTER

PROPOSAL FOR AUTOMOTIVE WORKSHOP ON AUTOMOBILE BASICS + ADVANCED SYSTEM STUDY

SYLLABUS

CLASS	PARTICULARS
1	Introduction to automobile
2	Review of Auto basics
3	Automobile Working Cycle
4	Basic Terms such as HP, Torque, Sp Fuel consumption, Gradability
5	Wheel bases, Turning radius, Tracks, Road reactions, Vehicle stability etc
6	Introduction to Passenger Cars
7	Tata Passenger Car Types
8	Latest Car Models of competitors
9	Modern Car engines
10	Multipoint Injection Petrol engine, Common Rail Direct Injection Diesel engine
11	Modern Diesel Engines: FIP, ECU, Common rail injection Systems
12	Clutch
13	Transmission
14	Differential working /Functioning
15	Suspension , Independent suspension, Antiroll bars
16	Torsion bars , Stabilizers
17	Braking system
18	Vacuum Brakes, ABS
19	EBD
20	ESP/ECSS
21	Safety features in TATA Motors passenger cars: Tata Car Safety features
22	Active and Passive Safety
23	Crash tests
24	Air bags
25	Roll over controls
26	Special slides and video on TATA motors vehicles
27	Study of Under body parts - Location and inter connectivity.
28	Physical Demonstration of Engine Assembly
29	Physical Demonstration of Clutch Assembly
30	Physical Demonstration of Gear Assembly

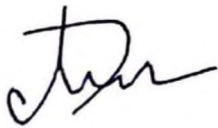

Program Coordinator



Head of the Department

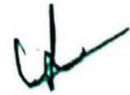

PRINCIPAL  
Nehru College of  
Engineering and Research Centre  
Pampady Thiruvilwamala Thrissur Dist  
Pin 680 597 Kerala

NEHRU COLLEGE OF ENGINEERING AND RESEARCH CENTRE  
PAMPADY, THIRUVILWAMALA - 680 588  
DEPARTMENT OF AUTOMOBILE ENGINEERING

NOTICE

As per the advice from the DAC meeting, it was decided to conduct the certificate course on "Proposal for Automotive Workshop on Automobile Basics + Advanced System Study" which will be conducted by having 30 hours of contact classes from 4 pm to 5 pm in the even semester of 2015-2016 academic year. Those who are interested to participate, enroll your name to your class advisor.

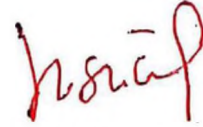

Head of the Department

To:

II, IV, VI, VIII Semester Classroom - AUE  
Principal  
Academic Office  
Notice Board - AUE



**PRINCIPAL**

Nehru College of  
Engineering and Research Centre  
Pampady, Thiruvilwamala, Thrissur Dt  
Pin 680 597 Kerala

# NEHRU COLLEGE OF ENGINEERING AND RESEARCH CENTRE

PAMPADY, THIRUVILWAMALA - 680 588

## DEPARTMENT OF AUTOMOBILE ENGINEERING

### ENROLLEMENT LIST OF CERTIFICATE COURSE - 2015-16 - EVEN SEMESTER

Course Name : Proposal for automotive workshop on automobile basics + advanced system study

Sl No	Register Number	Student Name	Semester	Year
1	NCAMEAU001	Abhijith Na	VIII	IV
2	NCAMEAU003	Abu Asad M	VIII	IV
3	NCAMEAU004	Achengadan James Davis	VIII	IV
4	NCAMEAU005	Ajith K	VIII	IV
5	NCAMEAU007	Akshay Dileep	VIII	IV
6	NCAMEAU008	Anoop M	VIII	IV
7	NCAMEAU009	Aravind Yadav	VIII	IV
8	NCAMEAU010	Arun C.r	VIII	IV
9	NCAMEAU012	Arun S Varma	VIII	IV
10	NCAMEAU013	Clins Thommy	VIII	IV
11	NCAMEAU014	Devanand C.t	VIII	IV
12	NCAMEAU015	Faes A.a	VIII	IV
13	NCAMEAU017	Gokul Ajith	VIII	IV
14	NCAMEAU018	Hiran K.h	VIII	IV
15	NCAMEAU020	Kanchan B	VIII	IV
16	NCAMEAU021	Krishna Das	VIII	IV
17	NCAMEAU025	Midhun M	VIII	IV
18	NCAMEAU026	Nair Vishnu Babu	VIII	IV
19	NCAMEAU027	Nithin Raj	VIII	IV
20	NCAMEAU028	Praveen Kumar N.k	VIII	IV
21	NCAMEAU029	Rahul Mohan	VIII	IV
22	NCAMEAU031	Rohith R Nath	VIII	IV
23	NCAMEAU032	Sachin Ravi K.r	VIII	IV
24	NCAMEAU033	Sajith N.s	VIII	IV
25	NCAMEAU034	Sajith U Menon	VIII	IV



**PRINCIPAL**

Nehru College of  
Engineering and Research Centre  
Pampady, Thiruvilwamala, Thrissur Dt  
Pin - 680 587 Kerala

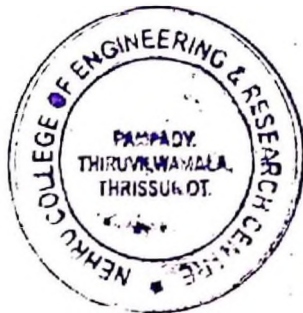

26	NCAMEAU035	Shuhaib Rahman K	VIII	IV
27	NCAMEAU036	Srijith R Nair	VIII	IV
28	NCAMEAU037	Unais Rahman	VIII	IV
29	NCAMEAU038	Vimal Dev I.p	VIII	IV
30	NCANEAU009	Ananthakrishnan C	VI	III
31	NCANEAU010	Anson Ps	VI	III
32	NCANEAU011	Anugrah P	VI	III
33	NCANEAU012	Anushob O V	VI	III
34	NCANEAU014	Aravind A	VI	III
35	NCANEAU016	Arju P K	VI	III
36	NCANEAU017	Ashiq .p.h	VI	III
37	NCANEAU018	Ashish C G	VI	III
38	NCANEAU019	Aswin Achuthan Palat	VI	III
39	NCANEAU020	Azlan Ali	VI	III
40	NCANEAU021	Carl Joy	VI	III
41	NCANEAU022	Deepak K S	VI	III
42	NCANEAU024	Gokul Raj	VI	III
43	NCANEAU025	Greejith M.g	VI	III
44	NCANEAU027	Harikrishna Yadav A.v	VI	III
45	NCANEAU030	Jishnu A.h	VI	III
46	NCANEAU031	Libin Andrews	VI	III
47	NCANEAU032	Midhun Mohan	VI	III
48	NCANEAU033	Mohammed Rusin Kafoor	VI	III
49	NCANEAU037	Rahul M R	VI	III
50	NCANEAU038	Rammohan C	VI	III
51	NCANEAU039	Ranjith Kr	VI	III
52	NCANEAU040	Raveen Krishna K	VI	III
53	NCANEAU041	Rinoy Johnson	VI	III
54	NCANEAU042	Sachin	VI	III
55	NCANEAU043	Sahal Ali Ahmed	VI	III
56	NCANEAU044	Sanad Thurakkal Puthan Purayil	VI	III

  
**PRINCIPAL**  
 Nehru College of  
 Engineering and Research Centre  
 Pampady, Thiruvilvamala, Thrissur, OT  
 Pin: 680 597 Kerala

57	NCANEAU045	Sanal Krishnan M	VI	III
58	NCANEAU047	Sandeep K	VI	III
59	NCANEAU048	Sandeep.m	VI	III
60	NCANEAU049	Sanil A A	VI	III
61	NCANEAU050	Santhanu Ajith	VI	III
62	NCANEAU051	Sarath Chandran K.t	VI	III
63	NCANEAU053	Sudin Sp	VI	III
64	NCANEAU054	Syam P.s	VI	III
65	NCANEAU055	Uday Harinarayanan	VI	III
66	NCANEAU057	K A Vidyasagar	VI	III
67	NCANEAU058	Vishnu Mohan	VI	III
68	NCANEAU059	Kowshik V	VI	III
69	NCANEAU060	Mahesh Venu	VI	III
70	NCANEAU061	Muhammed Jinas P	VI	III
71	NCANEAU062	Fayis Musthafa K.t	VI	III
72	NCANEAU063	Abhiram R	VI	III
73	NCANEAU064	MEBIN SUNNY	VI	III
74	NCANEAU065	Jeffy Simon Mathew	VI	III
75	NCANEAU066	Marshal A S	VI	III

*Principal*

Head of the Department



*[Signature]*  
PRINCIPAL  
Nehru College of  
Engineering and Research Centre  
Pampady Thiruvilwamala, Thrissur Dt  
Pin. 680 597 Kerala

NEHRU COLLEGE OF ENGINEERING AND RESEARCH CENTRE  
 PAMPADY, THIRUVILWAMALA - 680 588  
 DEPARTMENT OF AUTOMOBILE ENGINEERING  
 ATTENDANCE REGISTER OF CERTIFICATE COURSE - 2015-16 - EVEN SEMESTER  
 Course Name : Proposal for automotive workshop on automobile basics + advanced system study

Sl No	Register Number	Student Name	Hours																													
			1	2	3	4	5	6	7	8	9	10	11	12	13	14	15	16	17	18	19	20	21	22	23	24	25	26	27	28	29	30
1	NCAMEAU001	Abhijith Na	/	/	/	/	/	/	/	/	/	/	/	/	/	/	/	/	/	/	/	/	/	/	/	/	/	/	/	/	/	/
2	NCAMEAU003	Abu Asad M	/	/	/	/	/	/	/	/	/	/	/	/	/	/	/	/	/	/	/	/	/	/	/	/	/	/	/	/	/	/
3	NCAMEAU004	Achengadan James Davis	/	/	/	/	/	/	/	/	/	/	/	/	/	/	/	/	/	/	/	/	/	/	/	/	/	/	/	/	/	/
4	NCAMEAU005	Ajith K	/	/	/	/	/	/	/	/	/	/	/	/	/	/	/	/	/	/	/	/	/	/	/	/	/	/	/	/	/	/
5	NCAMEAU007	Akshay Dileep	/	/	/	/	/	/	/	/	/	/	/	/	/	/	/	/	/	/	/	/	/	/	/	/	/	/	/	/	/	/
6	NCAMEAU008	Anoop M	/	/	/	/	/	/	/	/	/	/	/	/	/	/	/	/	/	/	/	/	/	/	/	/	/	/	/	/	/	/
7	NCAMEAU009	Aravind Yadav	/	/	/	/	/	/	/	/	/	/	/	/	/	/	/	/	/	/	/	/	/	/	/	/	/	/	/	/	/	/
8	NCAMEAU010	Arun C.r	/	/	/	/	/	/	/	/	/	/	/	/	/	/	/	/	/	/	/	/	/	/	/	/	/	/	/	/	/	/
9	NCAMEAU012	Arun S Varma	/	/	/	/	/	/	/	/	/	/	/	/	/	/	/	/	/	/	/	/	/	/	/	/	/	/	/	/	/	/
10	NCAMEAU013	Clins Thommy	/	/	/	/	/	/	/	/	/	/	/	/	/	/	/	/	/	/	/	/	/	/	/	/	/	/	/	/	/	/
11	NCAMEAU014	Devanand C.t	/	/	/	/	/	/	/	/	/	/	/	/	/	/	/	/	/	/	/	/	/	/	/	/	/	/	/	/	/	/
12	NCAMEAU015	Faes A.a	/	/	/	/	/	/	/	/	/	/	/	/	/	/	/	/	/	/	/	/	/	/	/	/	/	/	/	/	/	/
13	NCAMEAU017	Gokul Ajith	/	/	/	/	/	/	/	/	/	/	/	/	/	/	/	/	/	/	/	/	/	/	/	/	/	/	/	/	/	/
14	NCAMEAU018	Hiran K.h	/	/	/	/	/	/	/	/	/	/	/	/	/	/	/	/	/	/	/	/	/	/	/	/	/	/	/	/	/	/
15	NCAMEAU020	Kanchan B	/	/	/	/	/	/	/	/	/	/	/	/	/	/	/	/	/	/	/	/	/	/	/	/	/	/	/	/	/	/
16	NCAMEAU021	Krishna Das	/	/	/	/	/	/	/	/	/	/	/	/	/	/	/	/	/	/	/	/	/	/	/	/	/	/	/	/	/	/
17	NCAMEAU025	Midhun M	/	/	/	/	/	/	/	/	/	/	/	/	/	/	/	/	/	/	/	/	/	/	/	/	/	/	/	/	/	/
18	NCAMEAU026	Nair Vishnu Babu	/	/	/	/	/	/	/	/	/	/	/	/	/	/	/	/	/	/	/	/	/	/	/	/	/	/	/	/	/	/
19	NCAMEAU027	Nithin Raj	/	/	/	/	/	/	/	/	/	/	/	/	/	/	/	/	/	/	/	/	/	/	/	/	/	/	/	/	/	/
20	NCAMEAU028	Praveen Kumar N.k	/	/	/	/	/	/	/	/	/	/	/	/	/	/	/	/	/	/	/	/	/	/	/	/	/	/	/	/	/	/
21	NCAMEAU029	Rahul Mohan	/	/	/	/	/	/	/	/	/	/	/	/	/	/	/	/	/	/	/	/	/	/	/	/	/	/	/	/	/	/
22	NCAMEAU031	Rohith R Nath	/	/	/	/	/	/	/	/	/	/	/	/	/	/	/	/	/	/	/	/	/	/	/	/	/	/	/	/	/	/
23	NCAMEAU032	Sachin Ravi K.r	/	/	/	/	/	/	/	/	/	/	/	/	/	/	/	/	/	/	/	/	/	/	/	/	/	/	/	/	/	/
24	NCAMEAU033	Sajith N.s	/	/	/	/	/	/	/	/	/	/	/	/	/	/	/	/	/	/	/	/	/	/	/	/	/	/	/	/	/	/
25	NCAMEAU034	Sajith U Menon	/	/	/	/	/	/	/	/	/	/	/	/	/	/	/	/	/	/	/	/	/	/	/	/	/	/	/	/	/	/
26	NCAMEAU035	Shuhaib Rahman K	/	/	/	/	/	/	/	/	/	/	/	/	/	/	/	/	/	/	/	/	/	/	/	/	/	/	/	/	/	/
27	NCAMEAU036	Srijith R Nair	/	/	/	/	/	/	/	/	/	/	/	/	/	/	/	/	/	/	/	/	/	/	/	/	/	/	/	/	/	/
28	NCAMEAU037	Unais Rahman	/	/	/	/	/	/	/	/	/	/	/	/	/	/	/	/	/	/	/	/	/	/	/	/	/	/	/	/	/	/
29	NCAMEAU038	Vimal Dev I.p	/	/	/	/	/	/	/	/	/	/	/	/	/	/	/	/	/	/	/	/	/	/	/	/	/	/	/	/	/	/
30	NCAMEAU009	Ananthakrishnan C	/	/	/	/	/	/	/	/	/	/	/	/	/	/	/	/	/	/	/	/	/	/	/	/	/	/	/	/	/	/
31	NCAMEAU010	Anson Ps	/	/	/	/	/	/	/	/	/	/	/	/	/	/	/	/	/	/	/	/	/	/	/	/	/	/	/	/	/	/
32	NCAMEAU011	Anugrah P	/	/	/	/	/	/	/	/	/	/	/	/	/	/	/	/	/	/	/	/	/	/	/	/	/	/	/	/	/	/
33	NCAMEAU012	Anushob D.V	/	/	/	/	/	/	/	/	/	/	/	/	/	/	/	/	/	/	/	/	/	/	/	/	/	/	/	/	/	/
34	NCAMEAU014	Aravind A	/	/	/	/	/	/	/	/	/	/	/	/	/	/	/	/	/	/	/	/	/	/	/	/	/	/	/	/	/	/
35	NCAMEAU016	Arju P.K	/	/	/	/	/	/	/	/	/	/	/	/	/	/	/	/	/	/	/	/	/	/	/	/	/	/	/	/	/	/
36	NCAMEAU017	Ashiq p.h	/	/	/	/	/	/	/	/	/	/	/	/	/	/	/	/	/	/	/	/	/	/	/	/	/	/	/	/	/	/
37	NCAMEAU018	Ashish C.G	/	/	/	/	/	/	/	/	/	/	/	/	/	/	/	/	/	/	/	/	/	/	/	/	/	/	/	/	/	/
38	NCAMEAU019	Aswin Achuthan Palat	/	/	/	/	/	/	/	/	/	/	/	/	/	/	/	/	/	/	/	/	/	/	/	/	/	/	/	/	/	/
39	NCAMEAU020	Azlan Ali	/	/	/	/	/	/	/	/	/	/	/	/	/	/	/	/	/	/	/	/	/	/	/	/	/	/	/	/	/	/
40	NCAMEAU021	Carl Joy	/	/	/	/	/	/	/	/	/	/	/	/	/	/	/	/	/	/	/	/	/	/	/	/	/	/	/	/	/	/

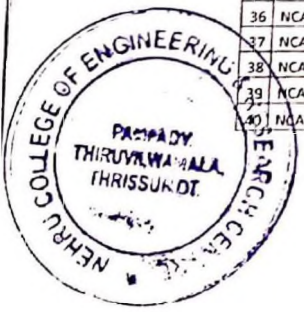

PRINCIPAL   
 Nehru College of Engineering and Research Centre  
 Pampady Thiruvilwamala, Thrissur Di  
 Pin 680 597 Kerala



NEHRU COLLEGE OF ENGINEERING AND RESEARCH CENTRE  
PAMPADY, THIRUVILWAMALA - 680 588

DEPARTMENT OF AUTOMOBILE ENGINEERING

CERTIFICATE COURSE – 2015-2016 – EVEN SEMESTER – EXAM

PROPOSAL FOR AUTOMOTIVE WORKSHOP ON AUTOMOBILE BASICS + ADVANCED SYSTEM STUDY

ANSWER KEY

Answer all the Questions

Max Marks: 50 Marks

1. The capacity of a battery is usually expressed in terms of  
(A) Volts (B) Amperes (C) Weight (D) **Ampere hours**
2. The most commonly used power plant in automobiles is  
(A) Gas turbine (B) **I.C. engine** (C) Battery (D) None of these
3. In a square type engine  
(A) Geometrical shape is square  
(B) Diameter and length of piston are same  
(C) Two cylinders are placed horizontal and two vertical  
(D) **Stroke length and cylinder bore are same**
4. The path taken by intake air is  
(A) Carburettor (or throttle body) air cleaner intake manifold intake ports cylinders  
(B) Air cleaner carburettor (or throttle body) intake ports intake manifold cylinders  
(C) Air cleaner intake manifold carburettor (or throttle body) intake ports cylinders  
(D) **Air cleaner carburettor (or throttle body) intake manifold intake ports cylinders**
5. The brake warning light warns the driver of  
(A) Water in the master cylinder  
(B) Air in the hydraulic system  
(C) **Failure of the primary or secondary circuit of hydraulic system**  
(D) Power brake failure
6. The connecting rods are generally made of \_\_\_\_\_ shaped cross-section.  
(A) **I** (B) C (C) L (D) H
7. It is necessary to maintain the valve clearances as they  
(A) Reduce the resistance to sliding that occurs between the cam and the tappet  
(B) **Allow for lengthening of the valves owing to the heat of combustion**  
(C) Increase the speed at which the valves move up and down  
(D) Make the crankshaft turn smoothly

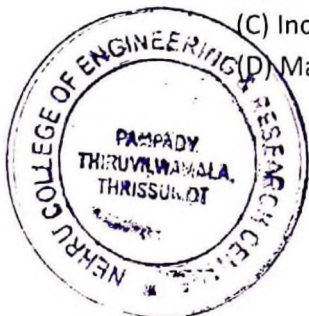

PRINCIPAL  
Nehru College of  
Engineering and Research Centre  
Pampady Thiruvilwamala Thiruvananthapuram Dt  
Pin 680 597 Kerala

8. The characteristic that is enhanced by the honing of cylinder sleeves inner surface is  
 (A) Cooling efficiency  
 (B) Resistance to wear  
 (C) **Lubrication performance**  
 (D) None of these
9. If the air-fuel mixture ignites before the spark takes place at spark plug, the condition is called  
 (A) Detonation (B) Ignition (C) **Pre-ignition** (D) Rumble
10. The instrument used to check specific gravity of acid in a battery is  
 (A) **Hydrometer** (B) Hygrometer (C) Anemometer (D) Multimeter
11. The crankshaft of a typical inline four cylinder engine has \_\_\_\_\_ balance weights.  
 (A) 12 (B) 4 (C) 16 (D) **8**
12. The condition that results in large quantities of HC emission is  
 (A) High temperature combustion (B) **Incomplete combustion**  
 (C) Low temperature combustion (D) High atmospheric temperature combustion
13. The engine oil viscosity is defined by \_\_\_\_\_ ratings.  
 (A) Automatic transmission fluid (ATF) (B) **Society of automotive engineers (SAE)**  
 (C) Gross vehicle weight (GVW) (D) American petroleum institute (API)
14. The negative plates of a lead acid battery has  
 (A) Lead peroxide ( $PbO_2$ ) (B) **Spongy lead (Pb)** (C) Lead sulphate ( $PbSO_4$ ) (D) Sulphuric acid ( $H_2SO_4$ )
15. The drive-shafts are connected to the differential and wheel hubs through universal joints because the universal joints  
 (A) Absorb the vibrations transferred from the surface of the road  
 (B) **Compensate for variations in the relative positions of the differential and the wheels** which result from bumpy road surfaces or other similar driving conditions.  
 (C) Absorb any difference in speed between the left and right wheels when the vehicle is turning  
 (D) None of the above

The octane rating of petrol commercially available is

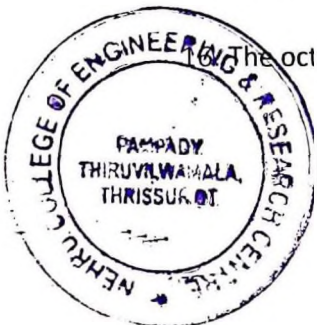

*[Handwritten Signature]*

**PRINCIPAL**

Nehru College of  
 Engineering and Research Centre  
 Panipady, Thiruvilwamala, Thrissur District  
 Pin 680 597 Kerala

(A) 85-95 (B) 95-100 (C) 100-110 (D) 110-125

17. The vehicle ride will be comfortable if

- (A) Unsprung mass is kept minimum (B) Sprung mass is kept minimum  
(C) Vehicle mass is kept minimum (D) All of these

18. The auto ignition in a spark ignition engine means

- (A) Automatic ignition of the charge at the end of compression  
(B) Ignition induced by the passage of a spark  
(C) Ignition of the charge before the passage of flame front  
(D) Ignition induced to supplement the process of normal combustion

19. When the brake pedal free play is less than the specified value, then the

- (A) Brake drags (B) Brake fades  
(C) Vapour locking occurs in the brake lines (D) Antilock braking system malfunctions

20. The acid used in automobile battery is

- (A) Hydrochloric acid (B) Hydrofluoric acid (C) Nitric acid (D) Sulphuric acid

21. Highest useful compression ratio (HUCR) is the highest compression ratio at which the

- (A) Engine can run (B) Engine gives maximum output  
(C) Engine is most efficient (D) Fuel can be used in a test engine without knocking

22. A petrol engine of a car develops 125 Nm torque at 2700 r.p.m. The car is driven in second gear having gear ratio of 1.75. The final drive ratio is 4.11. If the overall transmission efficiency is 90%, then the torque available at the driving wheels is

- (A) 8.091 Nm (B) 80.91 Nm (C) 809.1 Nm (D) 8091 Nm

23. The air gap between the central electrode and ground (or side) electrode of a spark plug is around

- (A) 0.2 mm (B) 0.5 mm (C) 1 mm (D) 1.5 mm

24. A four cylinder engine has a capacity of 2.4 litres. The swept volume of one cylinder is

- (A) 400 cm<sup>3</sup> (B) 600 cm<sup>3</sup> (C) 1200 cm<sup>3</sup> (D) 2400 cm<sup>3</sup>

25. The positive plates of a lead acid battery has

- (A) Lead peroxide (PbO<sub>2</sub>) (B) Spongy lead (Pb) (C) Lead sulphate (PbSO<sub>4</sub>) (D) Sulphuric acid (H<sub>2</sub>SO<sub>4</sub>)

## NEHRU COLLEGE OF ENGINEERING AND RESEARCH CENTRE

PAMPADY, THIRUVILWAMLA – 680 588



PRINCIPAL

Nehru College of  
Engineering and Research Centre  
Pampady, Thiruvilwamala, Thiruvananthapuram Dt  
Pin 680 597 Kerala

Student Name: Rohith R Nath

Register Number: NCAMEAU031

40  
50

20  
25

NEHRU COLLEGE OF ENGINEERING AND RESEARCH CENTRE  
PAMPADY, THIRUVILWAMALA - 680 588

DEPARTMENT OF AUTOMOBILE ENGINEERING

CERTIFICATE COURSE – 2015-2016 – EVEN SEMESTER – EXAM

PROPOSAL FOR AUTOMOTIVE WORKSHOP ON AUTOMOBILE BASICS + ADVANCED SYSTEM STUDY

Answer all the Questions and each question carry 2 marks

Max Marks: 50 Marks

1. The capacity of a battery is usually expressed in terms of  
(A) Volts (B) Amperes (C) Weight (D)  Ampere hours
2. The most commonly used power plant in automobiles is  
(A) Gas turbine (B)  I.C. engine (C) Battery (D) None of these
3. In a square type engine  
(A) Geometrical shape is square  
(B) Diameter and length of piston are same  
(C)  Two cylinders are placed horizontal and two vertical  
(D) Stroke length and cylinder bore are same
4. The path taken by intake air is  
(A) Carburettor (or throttle body) air cleaner intake manifold intake ports cylinders  
(B) Air cleaner carburettor (or throttle body) intake ports intake manifold cylinders  
(C) Air cleaner intake manifold carburettor (or throttle body) intake ports cylinders  
(D)  Air cleaner carburettor (or throttle body) intake manifold intake ports cylinders
5. The brake warning light warns the driver of  
(A) Water in the master cylinder  
(B) Air in the hydraulic system  
(C)  Failure of the primary or secondary circuit of hydraulic system  
(D) Power brake failure
6. The connecting rods are generally made of \_\_\_\_\_ shaped cross-section.  
(A)  I (B) C (C) L (D) H
7. It is necessary to maintain the valve clearances as they

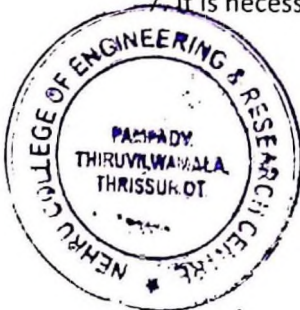

*Ct*

PRINCIPAL  
Nehru College of  
Engineering and Research Centre  
Pampady Thiruvilwamala, Thirissur Dt  
Pin 680 597 Kerala

Student Name:

Register Number:

- (A) Reduce the resistance to sliding that occurs between the cam and the tappet  
 (B) Allow for lengthening of the valves owing to the heat of combustion  
(C) Increase the speed at which the valves move up and down  
(D) Make the crankshaft turn smoothly
8. The characteristic that is enhanced by the honing of cylinder sleeves inner surface is  
(A) Cooling efficiency  
(B) Resistance to wear  
 (C) Lubrication performance  
(D) None of these
9. If the air-fuel mixture ignites before the spark takes place at spark plug, the condition is called  
(A) Detonation (B) Ignition  (C) Pre-ignition (D) Rumble
10. The instrument used to check specific gravity of acid in a battery is  
(A) Hydrometer  (B) Hygrometer (C) Anemometer (D) Multimeter
11. The crankshaft of a typical inline four cylinder engine has \_\_\_\_\_ balance weights.  
(A) 12 (B) 4 (C) 16  (D) 8
12. The condition that results in large quantities of HC emission is  
 (A) High temperature combustion (B) Incomplete combustion  
(C) Low temperature combustion (D) High atmospheric temperature combustion..
13. The engine oil viscosity is defined by \_\_\_\_\_ ratings.  
(A) Automatic transmission fluid (ATF)  (B) Society of automotive engineers (SAE)  
(C) Gross vehicle weight (GVW) (D) American petroleum institute (API)
14. The negative plates of a lead acid battery has  
(A) Lead peroxide ( $PbO_2$ ) (B) Spongy lead (Pb)  (C) Lead sulphate ( $PbSO_4$ ) (D) Sulphuric acid ( $H_2SO_4$ )
15. The drive-shafts are connected to the differential and wheel hubs through universal joints because the universal joints  
(A) Absorb the vibrations transferred from the surface of the road  
 (B) Compensate for variations in the relative positions of the differential and the wheels which result from bumpy road surfaces or other similar driving conditions.



  
PRINCIPAL  
Nehru College of  
Engineering and Research Centre  
Panapady Thiruvilwamala, Thrissur Dt  
Pin 680 597 Kerala

Student Name:

Register Number:

- (C) Absorb any difference in speed between the left and right wheels when the vehicle is turning  
(D) None of the above

16. The octane rating of petrol commercially available is  
 (A) 85-95 (B) 95-100 (C) 100-110 (D) 110-125

17. The vehicle ride will be comfortable if  
(A) Unsprung mass is kept minimum  (B) Sprung mass is kept minimum  
(C) Vehicle mass is kept minimum (D) All of these

18. The auto ignition in a spark ignition engine means  
(A) Automatic ignition of the charge at the end of compression  
(B) Ignition induced by the passage of a spark  
 (C) Ignition of the charge before the passage of flame front  
(D) Ignition induced to supplement the process of normal combustion

19. When the brake pedal free play is less than the specified value, then the  
 (A) Brake drags  (B) Brake fades  
(C) Vapour locking occurs in the brake lines (D) Antilock braking system malfunctions

20. The acid used in automobile battery is  
(A) Hydrochloric acid (B) Hydrofluoric acid (C) Nitric acid  (D) Sulphuric acid

21. Highest useful compression ratio (HUCR) is the highest compression ratio at which the  
(A) Engine can run (B) Engine gives maximum output  
(C) Engine is most efficient  (D) Fuel can be used in a test engine without knocking

22. A petrol engine of a car develops 125 Nm torque at 2700 r.p.m. The car is driven in second gear having gear ratio of 1.75. The final drive ratio is 4.11. If the overall transmission efficiency is 90%, then the torque available at the driving wheels is  
(A) 8.091 Nm (B) 80.91 Nm  (C) 809.1 Nm (D) 8091 Nm

23. The air gap between the central electrode and ground (or side) electrode of a spark plug is around  
(A) 0.2 mm (B) 0.5 mm  (C) 1 mm (D) 1.5 mm

24. A four cylinder engine has a capacity of 2.4 litres. The swept volume of one cylinder is  
(A) 400 cm<sup>3</sup>  (B) 600 cm<sup>3</sup> (C) 1200 cm<sup>3</sup> (D) 2400 cm<sup>3</sup>

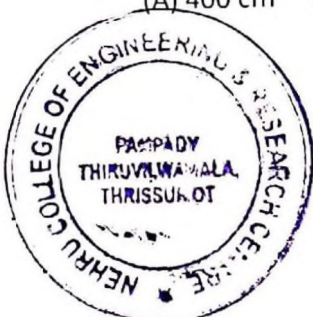

PRINCIPAL  
Nehru College of  
Engineering and Research Centre  
Panpady Thiruvilwala, Thiruvananthapuram  
Pin 680 597 Kerala

Student Name:

Register Number:

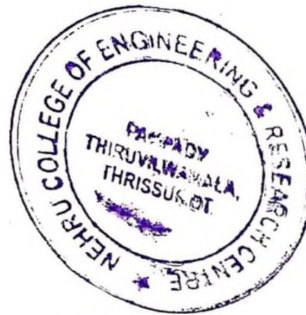

  
PRINCIPAL  
Nehru College of  
Engineering and Research Centre  
Pamoady, Thiruvilwamala Thrissur Dt  
Pin 680 597 Kerala

25. The positive plates of a lead acid battery has
- (A) Lead peroxide ( $\text{PbO}_2$ )    (B) Spongy lead ( $\text{Pb}$ )    (C) Lead sulphate ( $\text{PbSO}_4$ )    (D) Sulphuric acid ( $\text{H}_2\text{SO}_4$ )

Student Name: Sreejith R Nair

Register Number: NCAMEAU036

14/50

22/25

NEHRU COLLEGE OF ENGINEERING AND RESEARCH CENTRE

PAMPADY, THIRUVILWAMALA - 680 588

DEPARTMENT OF AUTOMOBILE ENGINEERING

CERTIFICATE COURSE – 2015-2016 – EVEN SEMESTER – EXAM

**PROPOSAL FOR AUTOMOTIVE WORKSHOP ON AUTOMOBILE BASICS + ADVANCED SYSTEM STUDY**

*Answer all the Questions and each question carry 2 marks*

*Max Marks: 50 Marks*

1. The capacity of a battery is usually expressed in terms of  
(A) Volts (B) Amperes (C) Weight (D)  Ampere hours
2. The most commonly used power plant in automobiles is  
(A) Gas turbine (B)  I.C. engine (C) Battery (D) None of these
3. In a square type engine  
(A) Geometrical shape is square  
(B) Diameter and length of piston are same  
(C)  Two cylinders are placed horizontal and two vertical  
(D) Stroke length and cylinder bore are same
4. The path taken by intake air is  
(A) Carburettor (or throttle body) air cleaner intake manifold intake ports cylinders  
(B) Air cleaner carburettor (or throttle body) intake ports intake manifold cylinders  
(C)  Air cleaner intake manifold carburettor (or throttle body) intake ports cylinders  
(D) Air cleaner carburettor (or throttle body) intake manifold intake ports cylinders
5. The brake warning light warns the driver of  
(A) Water in the master cylinder  
(B) Air in the hydraulic system  
(C)  Failure of the primary or secondary circuit of hydraulic system  
(D) Power brake failure
6. The connecting rods are generally made of \_\_\_\_\_ shaped cross-section.  
(A)  I (B) C (C) L (D) H
7. It is necessary to maintain the valve clearances as they  
(A) Reduce the resistance to sliding that occurs between the cam and the tappet  
(B) Allow for lengthening of the valves owing to the heat of combustion  
(C)  Increase the speed at which the valves move up and down  
(D) Make the crankshaft turn smoothly

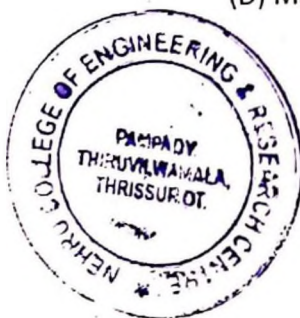

*[Signature]*

PRINCIPAL  
Nehru College of  
Engineering and Research Centre  
Pampady, Thiruvilwamala, Thrissur Dt  
Pin 680 597 Kerala

Student Name:

Register Number:

8. The characteristic that is enhanced by the honing of cylinder sleeves inner surface is  
(A) Cooling efficiency  
(B) Resistance to wear  
(C) Lubrication performance  
(D) None of these
9. If the air-fuel mixture ignites before the spark takes place at spark plug, the condition is called  
(A) Detonation (B) Ignition (C) Pre-ignition (D) Rumble
10. The instrument used to check specific gravity of acid in a battery is  
(A) Hydrometer (B) Hygrometer (C) Anemometer (D) Multimeter
11. The crankshaft of a typical inline four cylinder engine has \_\_\_\_\_ balance weights.  
(A) 12 (B) 4 (C) 16 (D) 8
12. The condition that results in large quantities of HC emission is  
(A) High temperature combustion (B) Incomplete combustion  
(C) Low temperature combustion (D) High atmospheric temperature combustion
13. The engine oil viscosity is defined by \_\_\_\_\_ ratings.  
(A) Automatic transmission fluid (ATF) (B) Society of automotive engineers (SAE)  
(C) Gross vehicle weight (GVW) (D) American petroleum institute (API)
14. The negative plates of a lead acid battery has  
(A) Lead peroxide ( $PbO_2$ ) (B) Spongy lead (Pb) (C) Lead sulphate ( $PbSO_4$ ) (D) Sulphuric acid ( $H_2SO_4$ )
15. The drive-shafts are connected to the differential and wheel hubs through universal joints because the universal joints  
(A) Absorb the vibrations transferred from the surface of the road  
(B) Compensate for variations in the relative positions of the differential and the wheels which result from bumpy road surfaces or other similar driving conditions.  
(C) Absorb any difference in speed between the left and right wheels when the vehicle is turning  
(D) None of the above



*cd*  
PRINCIPAL  
Nehru College of  
Engineering and Research Centre  
Pambooy Thruvilwamala Thrissur Dt  
Pin 680 597 Kerala

Student Name:

Register Number:

16. The octane rating of petrol commercially available is  
 (A) 85-95 (B) 95-100 (C) 100-110 (D) 110-125
17. The vehicle ride will be comfortable if:  
 (A) Unsprung mass is kept minimum (B) Sprung mass is kept minimum  
(C) Vehicle mass is kept minimum (D) All of these
18. The auto ignition in a spark ignition engine means  
(A) Automatic ignition of the charge at the end of compression  
(B) Ignition induced by the passage of a spark  
 (C) Ignition of the charge before the passage of flame front  
(D) Ignition induced to supplement the process of normal combustion
19. When the brake pedal free play is less than the specified value, then the  
 (A) Brake drags (B) Brake fades  
(C) Vapour locking occurs in the brake lines (D) Antilock braking system malfunctions
20. The acid used in automobile battery is  
(A) Hydrochloric acid (B) Hydrofluoric acid (C) Nitric acid  (D) Sulphuric acid
21. Highest useful compression ratio (HUCR) is the highest compression ratio at which the  
(A) Engine can run (B) Engine gives maximum output  
(C) Engine is most efficient  (D) Fuel can be used in a test engine without knocking
22. A petrol engine of a car develops 125 Nm torque at 2700 r.p.m. The car is driven in second gear having gear ratio of 1.75. The final drive ratio is 4.11. If the overall transmission efficiency is 90%, then the torque available at the driving wheels is  
(A) 8.091 Nm (B) 80.91 Nm (C) 809.1 Nm  (D) 8091 Nm
23. The air gap between the central electrode and ground (or side) electrode of a spark plug is around  
(A) 0.2 mm (B) 0.5 mm  (C) 1 mm (D) 1.5 mm
24. A four cylinder engine has a capacity of 2.4 litres. The swept volume of one cylinder is  
(A) 400 cm<sup>3</sup>  (B) 600 cm<sup>3</sup> (C) 1200 cm<sup>3</sup> (D) 2400 cm<sup>3</sup>
25. The positive plates of a lead acid battery has  
 (A) Lead peroxide (PbO<sub>2</sub>) (B) Spongy lead (Pb) (C) Lead sulphate (PbSO<sub>4</sub>) (D) Sulphuric acid (H<sub>2</sub>SO<sub>4</sub>)

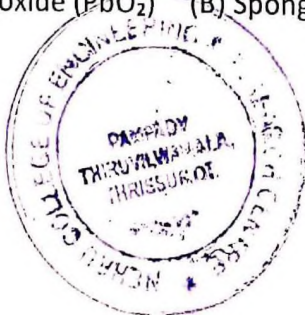

  
PRINCIPAL  
Nehru College of  
Engineering and Research Centre  
Pampady Thiruvilwamala Thiruvananthapuram  
Pin 680 597 Kerala

Student Name: Achengadan James Davis  
Register Number: NCAMEA0004

34  
50

17  
25

NEHRU COLLEGE OF ENGINEERING AND RESEARCH CENTRE

PAMPADY, THIRUVILWAMALA - 680 588

DEPARTMENT OF AUTOMOBILE ENGINEERING

CERTIFICATE COURSE - 2015-2016 - EVEN SEMESTER - EXAM

PROPOSAL FOR AUTOMOTIVE WORKSHOP ON AUTOMOBILE BASICS + ADVANCED SYSTEM STUDY

Answer all the Questions and each question carry 2 marks

Max Marks: 50 Marks

1. The capacity of a battery is usually expressed in terms of  
(A) Volts (B) Amperes (C) Weight (D)  Ampere hours
2. The most commonly used power plant in automobiles is  
(A) Gas turbine (B)  I.C. engine (C) Battery (D) None of these
3. In a square type engine  
(A) Geometrical shape is square  
(B) Diameter and length of piston are same  
(C) Two cylinders are placed horizontal and two vertical  
(D)  Stroke length and cylinder bore are same
4. The path taken by intake air is  
(A) Carburettor (or throttle body) air cleaner intake manifold intake ports cylinders  
(B) Air cleaner carburettor (or throttle body) intake ports intake manifold cylinders  
(C) Air cleaner intake manifold carburettor (or throttle body) intake ports cylinders  
(D)  Air cleaner carburettor (or throttle body) intake manifold intake ports cylinders
5. The brake warning light warns the driver of  
(A) Water in the master cylinder  
(B) Air in the hydraulic system  
(C)  Failure of the primary or secondary circuit of hydraulic system  
(D) Power brake failure
6. The connecting rods are generally made of \_\_\_\_\_ shaped cross-section.  
(A)  I (B) C (C) L (D) H
7. It is necessary to maintain the valve clearances as they  
(A) Reduce the resistance to sliding that occurs between the cam and the tappet  
(B)  Allow for lengthening of the valves owing to the heat of combustion  
(C) Increase the speed at which the valves move up and down  
(D) Make the crankshaft turn smoothly

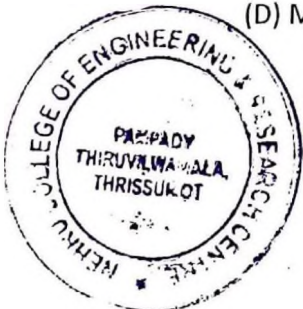

*U*

PRINCIPAL

Nehru College of  
Engineering and Research Centre  
Pampady Thiruvilwamala, Thrissur Dt  
Pin 680 597 Kerala

Student Name:

Register Number:

8. The characteristic that is enhanced by the honing of cylinder sleeves inner surface is  
(A) Cooling efficiency  
(B) Resistance to wear  
(C) Lubrication performance  
(D) None of these
9. If the air-fuel mixture ignites before the spark takes place at spark plug, the condition is called  
(A) Detonation (B) Ignition (C) Pre-ignition (D) Rumble
10. The instrument used to check specific gravity of acid in a battery is  
(A) Hydrometer (B) Hygrometer (C) Anemometer (D) Multimeter
11. The crankshaft of a typical inline four cylinder engine has \_\_\_\_\_ balance weights.  
(A) 12 (B) 4 (C) 16 (D) 8
12. The condition that results in large quantities of HC emission is  
(A) High temperature combustion (B) Incomplete combustion  
(C) Low temperature combustion (D) High atmospheric temperature combustion
13. The engine oil viscosity is defined by \_\_\_\_\_ ratings.  
(A) Automatic transmission fluid (ATF) (B) Society of automotive engineers (SAE)  
(C) Gross vehicle weight (GVW) (D) American petroleum institute (API)
14. The negative plates of a lead acid battery has  
(A) Lead peroxide ( $PbO_2$ ) (B) Spongy lead (Pb) (C) Lead sulphate ( $PbSO_4$ ) (D) Sulphuric acid ( $H_2SO_4$ )
15. The drive-shafts are connected to the differential and wheel hubs through universal joints because the universal joints  
(A) Absorb the vibrations transferred from the surface of the road  
(B) Compensate for variations in the relative positions of the differential and the wheels which result from bumpy road surfaces or other similar driving conditions.  
(C) Absorb any difference in speed between the left and right wheels when the vehicle is turning  
(D) None of the above



  
PRINCIPAL  
Nehru College of  
Engineering and Research Centre  
Pampady Thuvilwamala Thrissur Dt  
Pin 680 597 Kerala

Student Name:

Register Number:

16. The octane rating of petrol commercially available is  
(A) 85-95 (B) 95-100 (C) 100-110 (D) 110-125
17. The vehicle ride will be comfortable if  
(A) Unsprung mass is kept minimum (B) Sprung mass is kept minimum  
(C) Vehicle mass is kept minimum (D) All of these
18. The auto ignition in a spark ignition engine means  
(A) Automatic ignition of the charge at the end of compression  
(B) Ignition induced by the passage of a spark  
(C) Ignition of the charge before the passage of flame front  
(D) Ignition induced to supplement the process of normal combustion
19. When the brake pedal free play is less than the specified value, then the  
(A) Brake drags (B) Brake fades  
(C) Vapour locking occurs in the brake lines (D) Antilock braking system malfunctions
20. The acid used in automobile battery is  
(A) Hydrochloric acid (B) Hydrofluoric acid (C) Nitric acid (D) Sulphuric acid
21. Highest useful compression ratio (HUCR) is the highest compression ratio at which the  
(A) Engine can run (B) Engine gives maximum output  
(C) Engine is most efficient (D) Fuel can be used in a test engine without knocking
22. A petrol engine of a car develops 125 Nm torque at 2700 r.p.m. The car is driven in second gear having gear ratio of 1.75. The final drive ratio is 4.11. If the overall transmission efficiency is 90%, then the torque available at the driving wheels is  
(A) 8.091 Nm (B) 80.91 Nm (C) 809.1 Nm (D) 8091 Nm
23. The air gap between the central electrode and ground (or side) electrode of a spark plug is around  
(A) 0.2 mm (B) 0.5 mm (C) 1 mm (D) 1.5 mm
24. A four cylinder engine has a capacity of 2.4 litres. The swept volume of one cylinder is  
(A) 400 cm<sup>3</sup> (B) 600 cm<sup>3</sup> (C) 1200 cm<sup>3</sup> (D) 2400 cm<sup>3</sup>
25. The positive plates of a lead acid battery has  
(A) Lead peroxide (PbO<sub>2</sub>) (B) Spongy lead (Pb) (C) Lead sulphate (PbSO<sub>4</sub>) (D) Sulphuric acid (H<sub>2</sub>SO<sub>4</sub>)



  
PRINCIPAL  
Nehru College of  
Engineering and Research Centre  
Pampady Thiruvikramala Thrissur Dist  
Pin 680 597 Kerala

# NEHRU COLLEGE OF ENGINEERING AND RESEARCH CENTRE

PAMPADY, THIRUVILWAMALA - 680 588

## DEPARTMENT OF AUTOMOBILE ENGINEERING

### MARK LIST OF CERTIFICATE COURSE - 2015-16 - EVEN SEMESTER

Course Name : Proposal for automotive workshop on automobile basics + advanced system study

Sl No	Register Number	Student Name	Semester	Year	Marks
1	NCAMEAU001	Abhijith Na	VIII	IV	32
2	NCAMEAU003	Abu Asad M	VIII	IV	36
3	NCAMEAU004	Achengadan James Davis	VIII	IV	34
4	NCAMEAU005	Ajith K	VIII	IV	32
5	NCAMEAU007	Akshay Dileep	VIII	IV	36
6	NCAMEAU008	Anoop M	VIII	IV	32
7	NCAMEAU009	Aravind Yadav	VIII	IV	34
8	NCAMEAU010	Arun C.r	VIII	IV	38
9	NCAMEAU012	Arun S Varma	VIII	IV	34
10	NCAMEAU013	Clins Thommy	VIII	IV	46
11	NCAMEAU014	Devanand C.t	VIII	IV	34
12	NCAMEAU015	Faes A.a	VIII	IV	36
13	NCAMEAU017	Gokul Ajith	VIII	IV	38
14	NCAMEAU018	Hiran K.h	VIII	IV	36
15	NCAMEAU020	Kanchan B	VIII	IV	34
16	NCAMEAU021	Krishna Das	VIII	IV	42
17	NCAMEAU025	Midhun M	VIII	IV	38
18	NCAMEAU026	Nair Vishnu Babu	VIII	IV	36
19	NCAMEAU027	Nithin Raj	VIII	IV	34
20	NCAMEAU028	Praveen Kumar N.k	VIII	IV	34
21	NCAMEAU029	Rahul Mohan	VIII	IV	34
22	NCAMEAU031	Rohith R Nath	VIII	IV	40
23	NCAMEAU032	Sachin Ravi K.r	VIII	IV	34
24	NCAMEAU033	Sajith N.s	VIII	IV	36
25	NCAMEAU034	Sajith U Menon	VIII	IV	38
26	NCAMEAU035	Shuhaib Rahman K	VIII	IV	38
27	NCAMEAU036	Srijith R Nair	VIII	IV	44
28	NCAMEAU037	Unais Rahman	VIII	IV	32
29	NCAMEAU038	Vimal Dev I.p	VIII	IV	36
30	NCANEAU009	Ananthakrishnan C	VI	III	34
31	NCANEAU010	Anson Ps	VI	III	32
32	NCANEAU011	Anugrah P	VI	III	36
33	NCANEAU012	Anushob O V	VI	III	32
34	NCANEAU014	Aravind A	VI	III	34
35	NCANEAU016	Arju P K	VI	III	38
36	NCANEAU017	Ashiq .p.h	VI	III	34
37	NCANEAU018	Ashish C G	VI	III	46
38	NCANEAU019	Aswin Achuthan Palat	VI	III	34

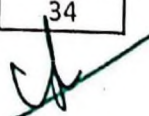

  
PRINCIPAL  
Nehru College of  
Engineering and Research Centre  
Pampady, Thiruvilwamala, Thrissur Dt  
Pin - 680 588

Sl No	Register Number	Student Name	Semester	Year	Marks
39	NCANEAU020	Azlan Ali	VI	III	36
40	NCANEAU021	Carl Joy	VI	III	38
41	NCANEAU022	Deepak K S	VI	III	36
42	NCANEAU024	Gokul Raj	VI	III	34
43	NCANEAU025	Greejith M.g	VI	III	42
44	NCANEAU027	Harikrishna Yadav A.v	VI	III	38
45	NCANEAU030	Jishnu A.h	VI	III	36
46	NCANEAU031	Libin Andrews	VI	III	34
47	NCANEAU032	Midhun Mohan	VI	III	34
48	NCANEAU033	Mohammed Rusin Kafoor	VI	III	34
49	NCANEAU037	Rahul M R	VI	III	40
50	NCANEAU038	Rammohan C	VI	III	34
51	NCANEAU039	Ranjith Kr	VI	III	36
52	NCANEAU040	Raveen Krishna K	VI	III	38
53	NCANEAU041	Rinoy Johnson	VI	III	38
54	NCANEAU042	Sachin	VI	III	44
55	NCANEAU043	Sahal Ali Ahmed	VI	III	32
56	NCANEAU044	Sanad Thurakkal Puthan Purayil	VI	III	36
57	NCANEAU045	Sanal Krishnan M	VI	III	34
58	NCANEAU047	Sandeep K	VI	III	32
59	NCANEAU048	Sandeep.m	VI	III	36
60	NCANEAU049	Sanil A A	VI	III	34
61	NCANEAU050	Santhanu Ajith	VI	III	36
62	NCANEAU051	Sarath Chandran K.t	VI	III	38
63	NCANEAU053	Sudin Sp	VI	III	38
64	NCANEAU054	Syam P.s	VI	III	44
65	NCANEAU055	Uday Harinarayanan	VI	III	32
66	NCANEAU057	K A Vidyasagar	VI	III	36
67	NCANEAU058	Vishnu Mohan	VI	III	34
68	NCANEAU059	Kowshik V	VI	III	32
69	NCANEAU060	Mahesh Venu	VI	III	36
70	NCANEAU061	Muhammed Jinas P	VI	III	38
71	NCANEAU062	Fayis Musthafa K.t	VI	III	34
72	NCANEAU063	Abhiram R	VI	III	36
73	NCANEAU064	MEBIN SUNNY	VI	III	34
74	NCANEAU065	Jeffy Simon Mathew	VI	III	32
75	NCANEAU066	Marshal A S	VI	III	30



*[Handwritten Signature]*

Head of the Department

*[Handwritten Signature]*

PRINCIPAL

Netru College of  
Engineering and Research Centre  
Pamady Thiruvilwamala, Thrissur Dt  
Pin 680 597 Kerala

Date: 4 / 8 / 2015

From

Deepak K P,  
Course Coordinator,  
Department of Automobile Engineering,  
Nehru College of Engineering and Research Centre  
Pampady, Thiruvilwamala - 680 588.

To

The Principal,  
Nehru College of Engineering and Research Centre  
Pampady, Thiruvilwamala - 680 588.

Through: HOD, Department of Automobile Engineering

Respected Sir,

SUB: Request for conducting Certificate Course for the even semester of 2015 - 2016 Academic Year - reg.

As per the circular number NCERC/3128/F/AC/29/15 on 26.06.2015, I may request your permission to conduct the certificate course for the even semester of the 2015-2016 academic year. The syllabus and lecture plan is attached herewith for your perusal.

Details of Course certificate:

Academic Year	Semester	Topic	Time	No of Hours
2015-2016	EVEN	Proposal for automotive workshop on automobile basics + advanced system study	4 pm - 5 pm	30

Kindly do the needful. Thank you.

Yours faithfully,



Deepak K P  
Assistant Professor - AUE.

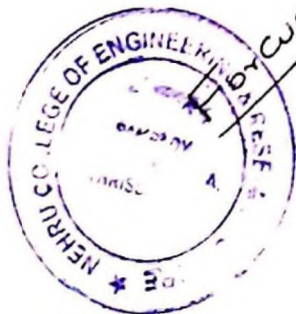

Approved & Forwarded To Principal

  
4/8/15





PRINCIPAL  
Nehru College of  
Engineering and Research Centre  
Pampady, Thiruvilwamala, Thrissur  
Pin - 680 597, Kerala

# ABOUT US

Nehru College of Engineering and Research Centre (NCERC), situated on the Bank of the river Nila, is a premier Engineering college that has pioneered engineering education, research and training in the private sector. Established in 2002 by the founder chairman Shri P.K. Das, NCERC is committed to impart world class quality education in engineering and research. Dedicated to the service in the realm of technical education in Kerala, it is an ISO 9001:2015 certified institution, approved by All India Council for Technical Education (AICTE), affiliated to A P J Abdul Kalam Technological University (KTU) and is accredited by National Assessment and Accreditation Council (NAAC).



[www.ncerc.ac.in](http://www.ncerc.ac.in)

  
 PRINCIPAL  
 Nehru College of  
 Engineering and Research Centre  
 Pampady Thiruvananthapuram, Kerala  
 Pin: 680 597 Kerala



NEHRU COLLEGE OF ENGINEERING  
 AND RESEARCH CENTRE, PAMPADY  
 THRISSUR.

PRESENTS

A COURSE ON

*Proposal for automotive workshop on  
 automobile basics + advanced system study*

DURING 2015-2016 EVEN SEMESTER

Cordinator

Mr. Deepak K P

DEPARTMENT OF AUTOMOBILE  
 ENGINEERING



## ABOUT THE COURSE

- ❖ This course will provide the college students a base to automotive technology.
- ❖ Students will learn about each and every driving systems involved in automation and get better understanding and grip on its application.
- ❖ The course providing insight into the structure and function of each component; vehicle integration; and related terms and working.



# Proposal for automotive workshop on automobile basics + advanced system study

## Course details

COURSE COORDINATOR



Mr. Deepak K P  
Assistant Professor,  
Departement of Automobile  
Engineering

### CONTACT

Email: [deepakkp@ncerc.ac.in](mailto:deepakkp@ncerc.ac.in)

Phone: 9895076253

  
PRINCIPAL  
Nehru College of  
Engineering and Research Center  
Pampady Thiruvananthapuram  
Pin - 680 567 Kerala



NEHRU COLLEGE OF ENGINEERING AND RESEARCH CENTRE  
THRISSUR - 680 588

*Is presented to*

*K A Vidyasagar*

*For successfully completing the course on "Proposal for automotive workshop on automobile basics + advanced system study" organised by Department of Automobile Engineering, Nehru College of Engineering and Research Centre, Thrissur during even semester of 2015-2016 academic year.*

Program Coordinator



HoD

PRINCIPAL  
Nehru College of  
Engineering and Research Centre  
Pampady Thiruvithamala Thrissur  
Pin - 680 587 Kerala



NEHRU COLLEGE OF ENGINEERING AND RESEARCH CENTRE  
THRISSUR - 680 588

*Is presented to*

**Sachin Ravi K R**

*For successfully completing the course on "Proposal for automotive workshop on automobile basics + advanced system study" organised by Department of Automobile Engineering, Nehru College of Engineering and Research Centre, Thrissur during even semester of 2015-2016 academic year.*

*Program Coordinator*

*HoD*

PRINCIPAL  
Nehru College of  
Engineering and Research Centre  
Pampady Thiruvithamala, Thrissur Dt  
Pin 680 597 Kerala





NEHRU COLLEGE OF ENGINEERING AND RESEARCH CENTRE



# Computer Science and Engineering



NEHRU COLLEGE OF ENGINEERING AND RESEARCH CENTRE  
THRISSUR - 680 588

*Is presented to*

*Sudin S P*

*For successfully completing the course on "Proposal for automotive workshop on automobile basics + advanced system study" organised by Department of Automobile Engineering, Nehru College of Engineering and Research Centre, Thrissur during even semester of 2015-2016 academic year.*

*Program Coordinator*

*HoD*

**PRINCIPAL**  
Nehru College of  
Engineering and Research Centre  
Pattipady Thiruvivamala, Thrissur, Kerala  
Pin - 680 588

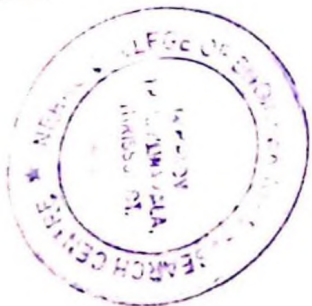

# NEHRU COLLEGE OF ENGINEERING AND RESEARCH CENTRE

(ACCREDITED BY NAAC)

PAMPADY, THIRUVILWAMALA, THRISSUR DIST.

## MINUTES OF DEPARTMENT ADVISORY COMMITTEE MEETING HELD ON 25/06/2015

A meeting of the Department Advisory Committee (DAC) was held on 25<sup>th</sup> June 2015 at 3:00 PM in the chamber of HoD. CSE department.

The following members were present:

1. Prof. Dr. S Subasree HoD, CSE Dept. *Suba*
2. Ms. Shinu Acca Mani-Assistant Professor, CSE Dept. *Shinu*
3. Ms. Meiji Jose -Assistant Professor, CSE Dept. *Meiji*
4. Ms. Silja Varghese-Assistant Professor, CSE Dept. *Silja*
5. Ms. Preethimol B -Assistant Professor, CSE Dept. *Preethimol*

### Agenda

- Discussing KTU syllabus
- Discussion on changes in mark distribution and additional activities to be done
- First series
- Certification course finalization

The following decisions were taken:

1. Awareness given to the staffs regarding the new syllabus and asked them to pass that to the students
2. Discussion was made on mark distribution in series, finalized the weightage of each questions according to new scheme
3. Decision was made to giving practical knowledge to students regarding upcoming technologies, as a part of that it has been decided to conduct a certificate course on "Big Data Analytics using Hadoop" from 06/07/2015 to 05/11/2015 for a period of 30 hours
4. staff advisors should ensure maximum participation and monitor the attendance.

The meeting came to an end at 3:50 PM.



*Suba*  
HoD *Suba*  
**PRINCIPAL**  
Nehru College of  
Engineering and Research Centre  
Pampady Thiruvilwamala, Thrissur Dt  
Pin 680 597 Kerala

Mark list

From,

Ms. Mary Mareena P.V,

Assistant Professor,

CSE Department, NCERC, PAMPADY.

To,

The Principal,

NCERC, PAMPADY.

Through HOD

Respected Madam,

SUBJECT: Request for Conducting a Certificate Course, Reg.

Students need a deep understanding of upcoming methodologies to enhance knowledge dissemination for doing projects. Big Data is used to better understand customers and their behaviors and preferences, so Computer Science and Engineering department would like to conduct a Certificate Course on "BIG DATA ANALYTICS USING HADOOP" from 06-07-2015. It will be a 30-hour course scheduled for July to October of this academic year 2015-2016. Kindly request you to give the permission for the same.

All UG/PG Engineering students of CSE Departments are Eligible for this course.

Thank you for your consideration. I look forward for your response soon.

Place: Pampady

Date: 25/6/2015

Forwarded to Principal  
B. Subraja  
25/6/2015  
ASW

Sincerely,

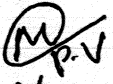
  
Mary Mareena P.V

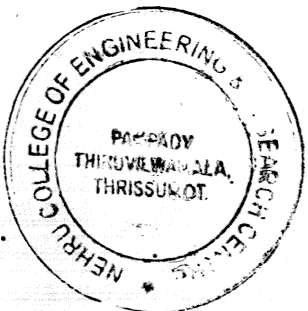

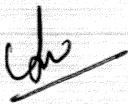

PRINCIPAL

Nehru College of  
Engineering and Research Centre  
Pampady, Thiruvilwamala, Thrissur Dt  
Pin - 680 597 Kerala



**NEHRU COLLEGE OF ENGINEERING AND RESEARCH CENTRE**  
**(NAAC Accredited)**  
(Approved by AICTE, Affiliated to University of Calicut and APJ Abdul Kalam Technological University, Kerala)



**ADMISSION TO ADD-ON COURSE (2015-2016)**

**Applications are invited for admission for the Add-On Course 'Big Data Analytics using Hadoop' offered by the Department of Computer Science and Engineering, Nehru College of Engineering and Research Centre, Pampady, Thrissur.**

**Eligibility Criteria:**

All UG/PG Engineering students of CSE department are Eligible.

Interested Students can give their names to respective class advisors on before 01-07-2015.

\*For First Years, Date is 05-08-2015.

**Timing:**

1 hour per day for 30 days from 4.00pm to 5.00pm. Saturday and Sunday may be used at the discretion of the Department.

**Attendance:**

A minimum of 75% attendance is required for writing the examination.

**Important Dates:**

Commencement of Classes: 06-07-2015

Examination date : 05-11-2015



HOD

**PRINCIPAL**  
Nehru College of  
Engineering and Research Centre  
Pampady, Thiruvilwamala, Thrissur Dt  
Pin 680 597 Kerala

**NCERC is a ISO 9001:2015 certified institution affiliated to AP J Abdul Kalam Technological University and approved by All India Council for Technical Education (AICTE). It is also accredited by NAAC. It offers 6 undergraduate and 4 Postgraduate program in Engineering, Computer Applications and Management. To make the students professionally worthy, the college has institutional membership of professional societies such as IEEE, ISTE, CSI, IE(INDIA), ISTD, AIMA, SEEM etc. to strengthen the values of the Institute and its Students.**

**College campus is located on the northern slopes of Thiruvilwamala, which merges with the banks of the holy river Nila. This undulating terrain of 40 acres with lush green vegetation is continuously swept and hugged by the gentle northern breeze that brings the purity, serenity and sweetness of the river Nila. This picturesque location shall linger nostalgically in the minds of anybody visiting this beautiful area. Endowed with an enchanting and breath-taking topography, lush green natural vegetation, virgin land, pollution free atmosphere, moderate temperature, plentiful of nectar like fresh water and salubrious climate, this is a sought after place for healthy life, clear thinking and pleasant learning experience.**

## CONTACT

[www.ncerc.ac.in](http://www.ncerc.ac.in)

ph:04884 282070 284000

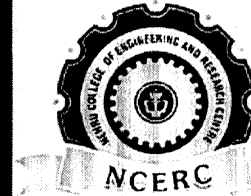

## Nehru College of Engineering and Research Centre, Pampady, Thrissur

Nehru College of Engineering and Research Centre (NCERC), one of the premier and vibrant Technical Institutions in Kerala, was started in the year 2002 under Nehru Group of Institutions (NGI) which was established in 1965 by Late Shri P. K. Das. There are 21 Institutions under NGI offering multiple courses from various areas including Aeronautics, Engineering, Management, MBBS, Pharmacy, IT, Nursing, Arts and Science.

**PRINCIPAL**  
Nehru College of  
Engineering and Research Centre  
Pampady Thiruvilwamala, Thrissur Dt  
Pin 680 597 Kerala

# BIG DATA USING HADOOP

## About the course

The Big Data Hadoop certification training is designed to give you an in-depth knowledge of the Big Data framework using Hadoop.

Hadoop is undoubtedly the preferred choice for such a requirement due to its key characteristics of being reliable, flexible, economical, and a scalable solution.

Big data analytics is the process of examining this large amount of different data types, or big data, in an effort to uncover hidden patterns, unknown correlations and other useful information.

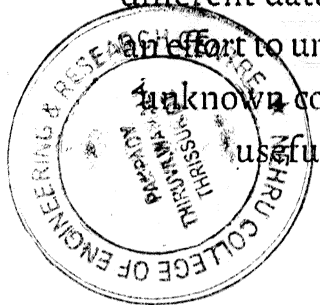

## Course details

Course Coordinator

Mary Mareena P V  
AP, CSE, NCERC

## Commencement of Classes

6-7-2015

Date of Exam

5-11-2015

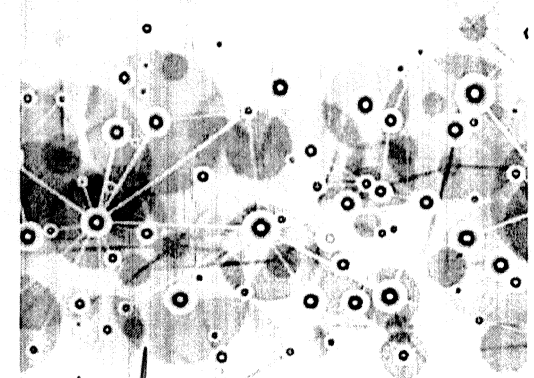

PRINCIPAL

Nehru College of  
Engineering and Research Centre  
Pampady Thiruvilwamala, Thiruvananthapuram Dt  
Pin 680 597 Kerala



**NEHRU COLLEGE OF ENGINEERING AND RESEARCH CENTRE  
(NAAC Accredited)**



(Approved by AICTE, Affiliated to University of Calicut and APJ Abdul Kalam Technological University, Kerala)

<b>BIG DATA ANALYTICS USING HADOOP syllabus</b>			
<b>Module</b>	<b>Contents</b>	<b>Hours</b>	<b>Exam Marks</b>
	<p><b>INTRODUCTION TO BIG DATA</b> Introduction to Big Data: Why Big Data and Where did it come from? Characteristics of Big Data- Volume, Variety, Velocity, Veracity, Valence, Value, Challenges and applications of Big Data.</p> <p>Introduction to Big Data Platforms, Overview of Apache Spark, HDFS, YARN, Introduction to MapReduce, MapReduce Programming Model with Spark, MapReduce Example: Word Count, Page Rank etc</p>	10	30%
II	<p>Introduction to Big Data Storage Platforms for Large Scale Data Storage, CAP Theorem, Eventual Consistency, Consistency Trade-Offs, ACID and BASE.</p> <p>Introduction to Big Data Streaming Platforms for Fast Data, Introduction to Big Data Streaming Systems, Big Data Pipelines for Real-Time computing. Hive.</p>	10	30%



**PRINCIPAL**  
Nehru College of  
Engineering and Research Centre  
Panipady, Thiruvilwamala, Thrissur Dt  
Pin 680 597 Kerala



**NEHRU COLLEGE OF ENGINEERING AND RESEARCH CENTRE**  
(NAAC Accredited)



(Approved by AICTE, Affiliated to University of Calicut and APJ Abdul Kalam Technological University, Kerala)

III	Introduction to Big Data Applications (Machine Learning), Overview of Big Data Machine Learning, Ma-hout Introduction.	10	40%
	Introduction to Big Data Applications (Graph Processing), Introduction to Pregel, Introduction to Giraph, Introduction to Spark GraphX		
<b>EXAM</b>			

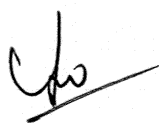

  
**PRINCIPAL**  
Nehru College of  
Engineering and Research Centre  
Panipady Thiruvilwamala, Thirissur Dt  
Pin 680 597 Kerala

**BIG DATA ANALYTICS USING HADOOP  
ATTENDANCE SHEET**

SL. NO.	REG NO	NAME	DATE																																
			1	2	3	4	5	6	7	8	9	10	11	12	13	14	15	16	17	18	19	20	21	22	23	24	25	26	27	28	29	30	31		
1	NCAMECS001	AARTNIRA M	/	/	/	/	/	/	/	/	/	/	/	/	/	/	/	/	/	/	/	/	/	/	/	/	/	/	/	/	/	/	/	/	
2	NCAMECS002	ABHIRAM G.M	/	/	/	/	/	/	/	/	/	/	/	/	/	/	/	/	/	/	/	/	/	/	/	/	/	/	/	/	/	/	/	/	
3	NCAMECS003	ARITHKUMAR K	/	/	/	/	/	/	/	/	/	/	/	/	/	/	/	/	/	/	/	/	/	/	/	/	/	/	/	/	/	/	/	/	
4	NCAMECS004	ANITH THOMAS	/	/	/	/	/	/	/	/	/	/	/	/	/	/	/	/	/	/	/	/	/	/	/	/	/	/	/	/	/	/	/	/	
5	NCAMECS005	AKASH V	/	/	/	/	/	/	/	/	/	/	/	/	/	/	/	/	/	/	/	/	/	/	/	/	/	/	/	/	/	/	/	/	
6	NCAMECS007	AKSHAY N	/	/	/	/	/	/	/	/	/	/	/	/	/	/	/	/	/	/	/	/	/	/	/	/	/	/	/	/	/	/	/	/	
7	NCAMECS008	AJUDA O S	/	/	/	/	/	/	/	/	/	/	/	/	/	/	/	/	/	/	/	/	/	/	/	/	/	/	/	/	/	/	/	/	
8	NCAMECS009	AMRUTHA C U	/	/	/	/	/	/	/	/	/	/	/	/	/	/	/	/	/	/	/	/	/	/	/	/	/	/	/	/	/	/	/	/	
9	NCAMECS010	AMRUTHAJAYARAJ K	/	/	/	/	/	/	/	/	/	/	/	/	/	/	/	/	/	/	/	/	/	/	/	/	/	/	/	/	/	/	/	/	
10	NCAMECS011	ANIL KIRAN S P	/	/	/	/	/	/	/	/	/	/	/	/	/	/	/	/	/	/	/	/	/	/	/	/	/	/	/	/	/	/	/	/	
11	NCAMECS012	ANIRUDH A WARRIER	/	/	/	/	/	/	/	/	/	/	/	/	/	/	/	/	/	/	/	/	/	/	/	/	/	/	/	/	/	/	/	/	
12	NCAMECS013	ANJALI I	/	/	/	/	/	/	/	/	/	/	/	/	/	/	/	/	/	/	/	/	/	/	/	/	/	/	/	/	/	/	/	/	
13	NCAMECS014	ANOOP JOHN	/	/	/	/	/	/	/	/	/	/	/	/	/	/	/	/	/	/	/	/	/	/	/	/	/	/	/	/	/	/	/	/	
14	NCAMECS015	ANU B	/	/	/	/	/	/	/	/	/	/	/	/	/	/	/	/	/	/	/	/	/	/	/	/	/	/	/	/	/	/	/	/	
15	NCAMECS016	ARJUN R SEKSHAR	/	/	/	/	/	/	/	/	/	/	/	/	/	/	/	/	/	/	/	/	/	/	/	/	/	/	/	/	/	/	/	/	/
16	NCAMECS017	ATHIRA P	/	/	/	/	/	/	/	/	/	/	/	/	/	/	/	/	/	/	/	/	/	/	/	/	/	/	/	/	/	/	/	/	/
17	NCAMECS018	ATHIRA T M	/	/	/	/	/	/	/	/	/	/	/	/	/	/	/	/	/	/	/	/	/	/	/	/	/	/	/	/	/	/	/	/	/
18	NCAMECS019	ATHIRA V	/	/	/	/	/	/	/	/	/	/	/	/	/	/	/	/	/	/	/	/	/	/	/	/	/	/	/	/	/	/	/	/	/
19	NCAMECS020	ATHULYA O K	/	/	/	/	/	/	/	/	/	/	/	/	/	/	/	/	/	/	/	/	/	/	/	/	/	/	/	/	/	/	/	/	/
20	NCAMECS021	BHAVYA K	/	/	/	/	/	/	/	/	/	/	/	/	/	/	/	/	/	/	/	/	/	/	/	/	/	/	/	/	/	/	/	/	/
21	NCAMECS022	CHARUTH S	/	/	/	/	/	/	/	/	/	/	/	/	/	/	/	/	/	/	/	/	/	/	/	/	/	/	/	/	/	/	/	/	/
22	NCAMECS023	DARSHANA	/	/	/	/	/	/	/	/	/	/	/	/	/	/	/	/	/	/	/	/	/	/	/	/	/	/	/	/	/	/	/	/	/
23	NCAMECS024	DEVI R	/	/	/	/	/	/	/	/	/	/	/	/	/	/	/	/	/	/	/	/	/	/	/	/	/	/	/	/	/	/	/	/	/
24	NCAMECS025	FIVEROSE P A	/	/	/	/	/	/	/	/	/	/	/	/	/	/	/	/	/	/	/	/	/	/	/	/	/	/	/	/	/	/	/	/	/
25	NCAMECS026	G APARNA	/	/	/	/	/	/	/	/	/	/	/	/	/	/	/	/	/	/	/	/	/	/	/	/	/	/	/	/	/	/	/	/	/
26	NCAMECS027	GREESHMA S	/	/	/	/	/	/	/	/	/	/	/	/	/	/	/	/	/	/	/	/	/	/	/	/	/	/	/	/	/	/	/	/	/
27	NCAMECS028	JESLY MOL A	/	/	/	/	/	/	/	/	/	/	/	/	/	/	/	/	/	/	/	/	/	/	/	/	/	/	/	/	/	/	/	/	/
28	NCAMECS029	JISHNU P V	/	/	/	/	/	/	/	/	/	/	/	/	/	/	/	/	/	/	/	/	/	/	/	/	/	/	/	/	/	/	/	/	/
29	NCAMECS030	KARTHIK RAGHUNATH	/	/	/	/	/	/	/	/	/	/	/	/	/	/	/	/	/	/	/	/	/	/	/	/	/	/	/	/	/	/	/	/	/

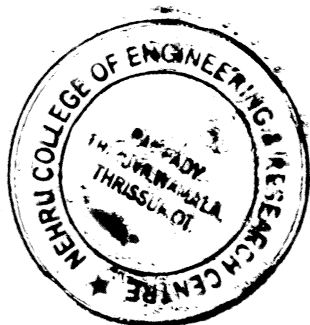

  
**PRINCIPAL**  
 Nehru College of  
 Engineering and Research Centre  
 Pampady Thiruvilwamala, Thiruvananthapuram Dt  
 Pin - 680 597 Kerala









COLLEGE OF E

Sl. No.	Name	1	2	3	4	5	6	7	8	9	10	11	12	13	14	15	16	17	18	19	20	
163	ADARSH																					
164	ADARSH																					
165	ADARSH																					
166	ADARSH																					
167	ADARSH																					
168	ADARSH																					
169	ADARSH																					
170	ADARSH																					
171	ADARSH																					
172	ADARSH																					
173	ADARSH																					
174	ADARSH																					
175	ADARSH																					
176	ADARSH																					
177	ADARSH																					
178	ADARSH																					
179	ADARSH																					
180	ADARSH																					
181	ADARSH																					
182	ADARSH																					
183	ADARSH																					
184	ADARSH																					
185	ADARSH																					
186	ADARSH																					
187	ADARSH																					
188	ADARSH																					
189	ADARSH																					
190	ADARSH																					
191	ADARSH																					
192	ADARSH																					
193	ADARSH																					
194	ADARSH																					
195	ADARSH																					
196	ADARSH																					
197	ADARSH																					
198	ADARSH																					
199	ADARSH																					
200	ADARSH																					
201	ADARSH																					
202	ADARSH																					
203	ADARSH																					
204	ADARSH																					
205	ADARSH																					

Engineering and Research Centre  
 Panipady Peruvilwamala Thiruvananthapuram  
 Pin - 680 597 Kerala

8 3 5 4 1 6 3 4 3 3 4 3 3 3 5 3 5 2 3 4 6 2 5 4 2

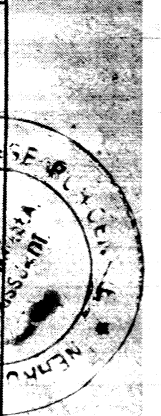



## QUESTION PAPER

1. As companies move past the experimental phase with Hadoop, many cite the need for additional capabilities, including \_\_\_\_\_
  - a) Improved data storage and information retrieval
  - b) Improved extract, transform and load features for data integration
  - c) Improved data warehousing functionality
  - d) Improved security, workload management and SQL support
2. Point out the correct statement.
  - a) Hadoop do need specialized hardware to process the data
  - b) Hadoop 2.0 allows live stream processing of real time data
  - c) In Hadoop programming framework output files are divided into lines or records
  - d) None of the mentioned
3. According to analysts, for what can traditional IT systems provide a foundation when they're integrated with big data technologies like Hadoop?
  - a) Big data management and data mining
  - b) Data warehousing and business intelligence
  - c) Management of Hadoop clusters
  - d) Collecting and storing unstructured data
4. Hadoop is a framework that works with a variety of related tools. Common cohorts include \_\_\_\_\_
  - a) MapReduce, Hive and HBase
  - b) MapReduce, MySQL and Google Apps
  - c) MapReduce, Hummer and Iguana
  - d) MapReduce, Heron and Trumpet
5. Point out the wrong statement.
  - a) Hardtop processing capabilities are huge and it's real advantage lies in the ability to process terabytes & petabytes of data
  - b) Hadoop uses a programming model called "MapReduce", all the programs should confirms to this model in order to work on Hadoop platform
  - c) The programming model, MapReduce, used by Hadoop is difficult to write and test
  - d) All of the mentioned
6. What was Hadoop named after?
  - a) Creator Doug Cutting's favorite circus act
  - b) Cutting's high school rock band
  - c) The toy elephant of Cutting's son
  - d) A sound Cutting's laptop made during Hadoop development
7. All of the following accurately describe Hadoop, EXCEPT \_\_\_\_\_
  - a) Open source
  - b) Real-time
  - c) Java-based
  - d) Distributed computing approach

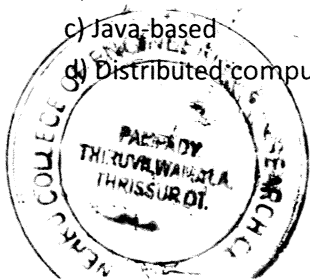

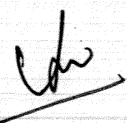
  
**PRINCIPAL**  
Nehru College of  
Engineering and Research Centre  
Panpady Thiruvithwamala, Thrissur Dt  
Pin 680 597 Kerala

8. \_\_\_\_\_ can best be described as a programming model used to develop Hadoop-based applications that can process massive amounts of data.
- a) MapReduce
  - b) Mahout
  - c) Oozie
  - d) All of the mentioned
9. \_\_\_\_\_ has the world's largest Hadoop cluster.
- a) Apple
  - b) Datamatics
  - c) Facebook
  - d) None of the mentioned
10. Facebook Tackles Big Data With \_\_\_\_\_ based on Hadoop.
- a) 'Project Prism'
  - b) 'Prism'
  - c) 'Project Big'
  - d) 'Project Data'
11. Replicated joins are useful for dealing with data skew.
- a) True
  - b) False
12. Maximum size allowed for small dataset in replicated join is:
- a) 10KB
  - b) 10 MB
  - c) 100 MB
  - d) 500 MB
13. Parameters could be passed to Pig scripts from:
- a) Parent Pig Scripts
  - b) Shell Script
  - c) Command Line
  - d) Configuration File
  - e) All the above except (a)
14. The schema of a relation can be examined through:
- a) ILLUSTRATE
  - b) DESCRIBE
  - c) DUMP
  - d) EXPLAIN
15. DUMP Statement writes the output in a file.
- a) True
  - b) False
16. Data can be supplied to PigUnit tests from:
- a) HDFS Location
  - b) Within Program
  - c) Both (a) and (b)
  - d) None of the above
17. Which of the following constructs are valid Pig Control Structures?
- a) If-else

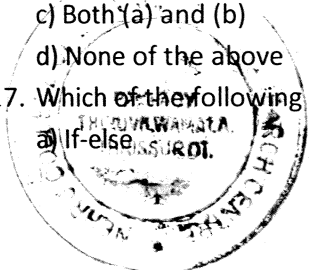

Handwritten signature of the Principal.

**PRINCIPAL**  
Nehru College of  
Engineering and Research Centre  
Pampady Thiruvilwamala, Thrissur Dt.  
Pin 680 597 Kerala

- b) For Loop
  - c) Until Loop
  - d) None of the above
18. Which of following is the return data type of Filter UDF?
- a) String
  - b) Integer
  - c) Boolean
  - d) None of the above
19. UDFs can be applied only in FOREACH statements in Pig.
- a) True
  - b) False
20. Which of the following are not possible in Hive?
- a) Creating Tables
  - b) Creating Indexes
  - c) Creating Synonym
  - d) Writing Update Statements
  - e) Both (c) and (d)
21. Who will initiate the mapper?
- a) Task tracker
  - b) Job tracker
  - c) Combiner
  - d) Reducer
22. Which of the following are the Big Data Solutions Candidates?
- a) Processing 1.5 TB data everyday
  - b) Processing 30 minutes Flight sensor data
  - c) Interconnecting 50K data points (approx. 1 MB input file)
  - d) Processing User clicks on a website
  - e) All of the above
23. Hadoop is a framework that allows the distributed processing of:
- a) Small Data Sets
  - b) Semi-Large Data Sets
  - c) Large Data Sets
  - d) Large and Small Data sets
24. Where does Sqoop ingest data from?
- a) Linux File Directory
  - b) Oracle
  - c) HBase
  - d) MySQL
  - e) MongoDB
25. Identify the batch processing scenarios from following:
- a) Sliding Window Averages Job
  - b) Facebook Comments Processing Job
  - c) Inventory Dynamic Pricing Job
  - d) Fraudulent Transaction Identification Job
  - e) Financial Forecasting Job

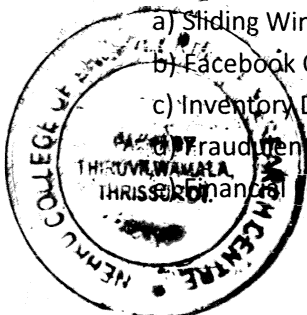

*cd*

**PRINCIPAL**  
Nehru College of  
Engineering and Research Centre  
Pampady Thiruvilwamala, Thirissur Dt  
Pin 680 597 Kerala

26. Which of the following are NOT metadata items?
- a) List of HDFS files
  - b) HDFS block locations
  - c) Replication factor of files
  - d) Access Rights
  - e) File Records distribution
27. What decides number of Mappers for a MapReduce job?
- a) File Location
  - b) mapred.map.tasks parameter
  - c) Input file size
  - d) Input Splits
28. Name Node monitors block replication process
- a) TRUE
  - b) FALSE
  - c) Depends on file type
29. Which of the following are true for Hadoop Pseudo Distributed Mode?
- a) It runs on multiple machines
  - b) Runs on multiple machines without any daemons
  - c) Runs on Single Machine with all daemons
  - d) Runs on Single Machine without all daemons
30. Which of following statement(s) are correct?
- a) Master and slaves files are optional in Hadoop 2.x
  - b) Master file has list of all name nodes
  - c) Core-site has hdfs and MapReduce related common properties
  - d) hdfs-site file is now deprecated in Hadoop 2.x
31. Which of the following is true for Hive?
- a) Hive is the database of Hadoop
  - b) Hive supports schema checking
  - c) Hive doesn't allow row level updates
  - d) Hive can replace an OLTP system
32. Which of the following is the highest level of Data Model in Hive?
- a) Table
  - b) View
  - c) Database
  - d) Partitions
33. Hive queries response time is in order of
- a) Hours at least
  - b) Minutes at least
  - c) Seconds at least
  - d) Milliseconds at least
34. Managed tables in Hive:
- a) Can load the data only from HDFS
  - b) Can load the data only from local file system
  - c) Are useful for enterprise wide data
  - d) Are Managed by Hive for their data and metadata

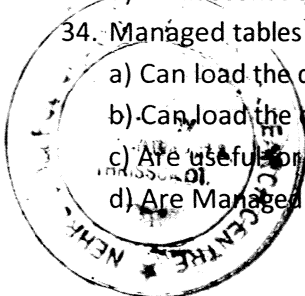

**PRINCIPAL**  
Nehru College of  
Engineering and Research Centre  
Pampady, Thiruvithwamala, Thiruvananthapuram Dt  
Pin 680 597 Kerala

35. Partitioned tables in Hive:
- Are aimed to increase the performance of the queries
  - Modify the underlying HDFS structure
  - Are not useful if the filter columns for query are different from the partition columns
  - All of the above
36. Hive UDFs can only be written in Java
- True
  - False
37. Hive can load the data from:
- Local File system
  - HDFS File system
  - Output of a Pig Job
  - All of the above
38. HBase is a key/value store. Specifically it is:
- Sparse
  - Sorted Map
  - Distributed
  - Consistent
  - Multi- dimensional
39. Which of the following is the outer most part of HBase data model
- Database
  - Table
  - Row key
  - Column family
40. Data can be loaded in HBase from Pig using
- PigStorage
  - SqoopStorage
  - BinStorage
  - HbaseStorage
41. Sqoop can load the data in HBase
- True
  - False
42. Which of the following APIs can be used for exploring HBase tables?
- HBaseDescriptor
  - HBaseAdmin
  - Configuration
  - HTable
43. Which of the following tables in HBase holds the region to key mapping?
- ROOT
  - .META.
  - MAP
  - REGIONS
44. What is the data type of version in HBase?
- INT
  - LONG

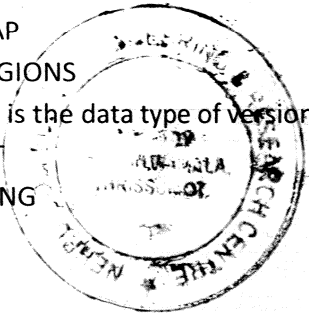

  
**PRINCIPAL**  
 Nehru College of  
 Engineering and Research Centre  
 Pampady Thiruvilwamala Thiruvananthapuram Dt  
 Pin 680 597 Kerala

- c) STRING
  - d) DATE
45. What is the data type of row key in HBase?
- a) INT
  - b) STRING
  - c) BYTE
  - d) BYTE[]
46. HBase first reads the data from
- a) Block Cache
  - b) Memstore
  - c) HFile
  - d) WAL
47. The High availability of Namenode is achieved in HDFS2.x using
- a) Polled Edit Logs
  - b) Synchronized Edit Logs
  - c) Shared Edit Logs
  - d) Edit Logs Replacement
48. The application master monitors all Map Reduce applications in the cluster
- a) True
  - b) False
49. HDFS Federation is useful for the cluster size of:
- a) >500 nodes
  - b) >900 nodes
  - c) > 5000 nodes
  - d) > 3500 nodes
50. Hive managed tables stores the data in
- a) Local Linux path
  - b) Any HDFS path
  - c) HDFS warehouse path
  - d) None of the above
51. On dropping managed tables, Hive:
- a) Retains data, but deletes metadata
  - b) Retains metadata, but deletes data
  - c) Drops both, data and metadata
  - d) Retains both, data and metadata
52. Managed tables don't allow loading data from other tables.
- a) True b) False
53. External tables can load the data from warehouse Hive directory.
- a) True b) False
54. On dropping external tables, Hive:
- a) Retains data, but deletes metadata
  - b) Retains metadata, but deletes data
  - c) Drops both, data and metadata
  - d) Retains both, data and metadata

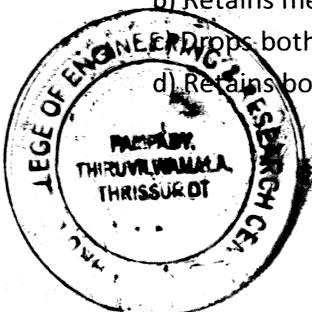

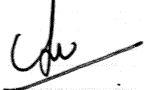
  
PRINCIPAL  
Nehru College of  
Engineering and Research Centre  
Pampady, Thiruvilwamala, Thrikkur Dt  
Pin - 680 597 Kerala

55. Partitioned tables can't load the data from normal (partitioned) tables

- a) True
- b) False

56. The partitioned columns in Hive tables are

- a) Physically present and can be accessed
- b) Physically absent but can be accessed
- c) Physically present but can't be accessed
- d) Physically absent and can't be accessed

57. Hive data models represent

- a) Table in Metastore DB
- b) Table in HDFS
- c) Directories in HDFS
- d) None of the above

58. When is the earliest point at which the reduce method of a given Reducer can be called?

- A. As soon as at least one mapper has finished processing its input split.
- B. As soon as a mapper has emitted at least one record.
- C. Not until all mappers have finished processing all records.
- D. It depends on the InputFormat used for the job.

59. According to analysts, for what can traditional IT systems provide a foundation when they're integrated with big data technologies like Hadoop?

- A. Big data management and data mining
- B. Data warehousing and business intelligence
- C. Management of Hadoop clusters
- D. Collecting and storing unstructured data

60. All of the following accurately describe Hadoop, EXCEPT:

- A. Open source
- B. Real-time
- C. Java-based
- D. Distributed computing approach

61. \_\_\_\_\_ has the world's largest Hadoop cluster.

- A. Apple
- B. Datamatics
- C. Facebook
- D. None of the mentioned

62. What are the five V's of Big Data?

- A. Volume
- B. Velocity
- C. Variety
- D. All the above

63. \_\_\_\_\_ hides the limitations of Java behind a powerful and concise Clojure API for Cascading.

- A. Scalding
- B. Casealog
- C. Hcatalog
- D. Haldin

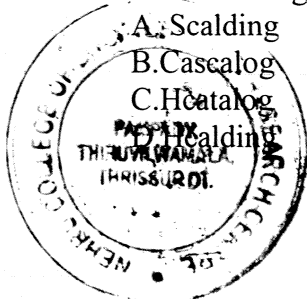

  
**PRINCIPAL**  
Nehru College of  
Engineering and Research Centre  
Paripady, Thiruvitwamala, Thirissur Dt  
Pin 686 597 Kerala

64. Which of the following can be used to control the number of part files in a map reduce program output directory?
- a) Number of Mappers
  - b) Number of Reducers
  - c) Counter
  - d) Partitioner
65. Which of the following operations can't use Reducer as combiner also?
- a) Group by Minimum
  - b) Group by Maximum
  - c) Group by Count
  - d) Group by Average
66. Which of the following is/are true about combiners?
- a) Combiners can be used for mapper only job
  - b) Combiners can be used for any Map Reduce operation
  - c) Mappers can be used as a combiner class
  - d) Combiners are primarily aimed to improve Map Reduce performance
  - e) Combiners can't be applied for associative operations
67. Reduce side join is useful for
- a) Very large datasets
  - b) Very small data sets
  - c) One small and other big data sets
  - d) One big and other small datasets
68. Distributed Cache can be used in
- a) Mapper phase only
  - b) Reducer phase only
  - c) In either phase, but not on both sides simultaneously
  - d) In either phase
69. Counters persist the data on hard disk.
- a) True
  - b) False
70. What is optimal size of a file for distributed cache?
- a)  $\leq 10$  MB
  - b)  $\geq 250$  MB
  - c)  $\leq 100$  MB
  - d)  $\leq 35$  MB
71. Number of mappers is decided by the
- a) Mappers specified by the programmer
  - b) Available Mapper slots
  - c) Available heap memory
  - d) Input Splits
  - e) Input Format
72. Which of the following type of joins can be performed in Reduce side join operation?
- a) Equi Join
  - b) Left Outer Join
  - c) Right Outer Join

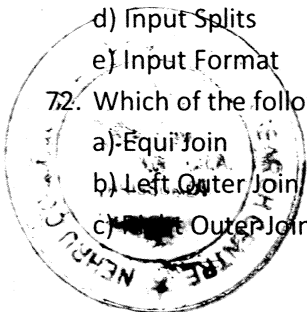

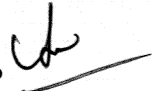
  
PRINCIPAL  
Nehru College of  
Engineering and Research Centre  
Panipady Thiruvilwamala, Thrissur Dt  
Pin 680 597 Kerala

- d) Full Outer Join
  - e) All of the above
73. What should be an upper limit for counters of a Map Reduce job?
- a) ~5s
  - b) ~15
  - c) ~150
  - d) ~50
74. Which of the following class is responsible for converting inputs to key-value Pairs of Map Reduce
- a) FileInputFormat
  - b) InputSplit
  - c) RecordReader
  - d) Mapper
75. Which of the following writables can be used to know value from a mapper/reducer?
- a) Text
  - b) IntWritable
  - c) NullWritable
  - d) String
76. Distributed cache files can't be accessed in Reducer.
- a) True
  - b) False
77. Only one distributed cache file can be used in a Map Reduce job.
- a) True
  - b) False
78. A Map reduce job can be written in:
- a) Java
  - b) Ruby
  - c) Python
  - d) Any Language which can read from input stream
79. Pig is a:
- a) Programming Language
  - b) Data Flow Language
  - c) Query Language
  - d) Database
80. Pig is good for:
- a) Data Factory operations
  - b) Data Warehouse operations
  - c) Implementing complex SQLs
  - d) Creating multiple datasets from a single large dataset
  - e) Both (a) and (d)
81. Pig can be used for real-time data updates.
- a) True
  - b) False

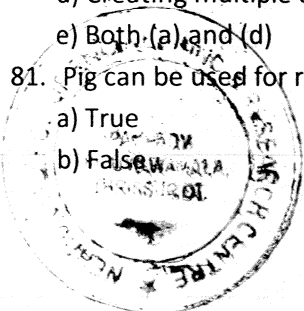

**PRINCIPAL**  
Nehru College of  
Engineering and Research Centre  
Pampady Thiruvilwamala, Thiruvananthapuram Dt  
Pin 680 597 Kerala

82. Pig jobs have the same run time as the native Map Reduce jobs.
- True
  - False
83. Which of the following is the correct representation to access "Skill" from the Bag {'Skills',55, ('Skill', 'Speed'), {2, ('San', 'Mateo')}}
- \$3.\$1
  - \$3.\$0
  - \$2.\$0
  - \$2.\$1
84. NameNode tries to keep the first copy of data nearest to the client machine.
- ALWAYS true
  - ALWAYS False
  - True if the client machine is the part of the cluster
  - True if the client machine is not the part of the cluster
85. HDFS data blocks can be read in parallel.
- TRUE
  - FALSE
86. Where is HDFS replication factor controlled?
- mapred-site.xml
  - yarn-site.xml
  - core-site.xml
  - hdfs-site.xml
87. Read the statement and select the correct option:  
It is necessary to default all the properties in Hadoop config files.
- True
  - False
88. Which of the following Hadoop config files is used to define the heap size?
- hdfs-site.xml
  - core-site.xml
  - hadoop-env.sh
  - Slaves
89. Which of the following is not a valid Hadoop config file?
- mapred-site.xml
  - hadoop-site.xml
  - core-site.xml
  - Masters
90. Read the statement:  
NameNodes are usually high storage machines in the clusters.
- True
  - False
  - Depends on cluster size
  - True if co-located with Job tracker
91. From the options listed below, select the suitable data sources for flume.
- Publicly open web sites
  - Local data folders

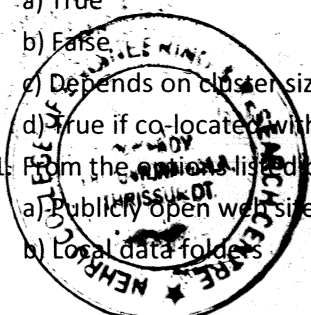

**PRINCIPAL**  
Nehru College of  
Engineering and Research Centre  
Pampady, Thiruvilwamala, Thrissur Dt  
Pin 680 597 Kerala

- c) Remote web servers  
d) Both (a) and (c)
92. Read the statement and select the correct options:  
distcp command ALWAYS needs fully qualified hdfs paths.
- a) True  
b) False  
c) True, if source and destination are in same cluster  
d) False, if source and destination are in same cluster
93. Which of following statement(s) are true about distcp command?
- a) It invokes MapReduce in background  
b) It invokes MapReduce if source and destination are in same cluster  
c) It can't copy data from local folder to hdfs folder  
d) You can't overwrite the files through distcp command
94. Which of the following is NOT the component of Flume?
- a) Sink  
b) Database  
c) Source  
d) Channel
95. Data can be supplied to PigUnit tests from:
- a) HDFS Location  
b) Within Program  
c) Both (a) and (b)  
d) None of the above
96. Which of the following constructs are valid Pig Control Structures?
- a) If-else  
b) For Loop  
c) Until Loop  
d) None of the above
97. Which of following is the return data type of Filter UDF?
- a) String  
b) Integer  
c) Boolean  
d) None of the above
98. UDFs can be applied only in FOREACH statements in Pig.
- a) True  
b) False
99. Which of the following are not possible in Hive?
- a) Creating Tables  
b) Creating Indexes  
c) Creating Synonym  
d) Writing UDFs Statements  
e) Both (c) and (d)
100. Who will initiate the mapper?
- a) Task tracker  
b) Job tracker

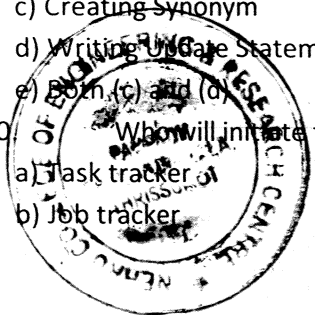

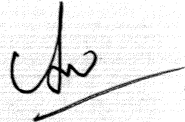
  
**PRINCIPAL**  
 Nehru College of  
 Engineering and Research Centre  
 Pampady, Thiruvilwamala, Thiruvananthapuram Dt  
 Pin 680 597 Kerala

- c) Combiner
- d) Reducer

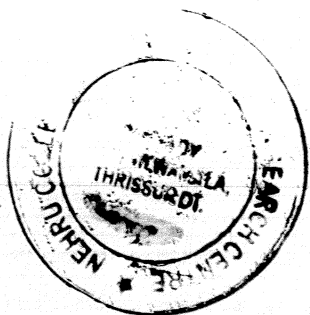

A handwritten signature in black ink, appearing to be "C. S. S.", written over a horizontal line.

**PRINCIPAL**

Neeru College of  
Engineering and Research Centre  
Pampady, Thiruvilwamala, Thirissur Dt  
Pin 680 597 Kerala

## ANSWER KEY

1	D	26	E	51	C	76	B
2	B	27	C	52	D	77	B
3	A	28	B	53	A	78	D
4	A	29	C	54	A	79	B
5	C	30	C	55	B	80	E
6	C	31	C	56	B	81	B
7	B	32	C	57	C	82	B
8	A	33	C	58	C	83	A
9	C	34	D	59	A	84	C
10	A	35	D	60	B	85	A
11	B	36	B	61	C	86	D
12	C	37	D	62	D	87	B
13	E	38	E	63	B	88	C
14	B	39	A	64	B	89	B
15	D	40	D	65	D	90	B
16	C	41	A	66	D	91	D
17	D	42	D	67	A	92	A
18	C	43	B	68	D	93	A
19	A	44	B	69	B	94	B
20	E	45	D	70	C	95	C
21	A	46	B	71	D	96	D
22	E	47	C	72	E	97	C
23	C	48	B	73	D	98	A
24	B	49	C	74	C	99	E
25	C	50	C	75	C	100	A

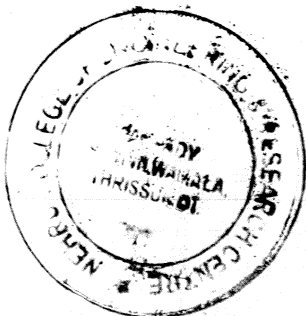

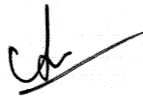
  
**PRINCIPAL**  
 Nehru College of  
 Engineering and Research Centre  
 Paripady Thiruvilwamala, Thiruvananthapuram  
 Pin 630 597 Kerala

**BIG DATA ANALYTICS USING HADOOP**

NAME:

REG NO:

72  
100

ADD ON COURSE QUESTION PAPER  
DURATION: 2 HOURS

1. As companies move past the experimental phase with Hadoop, many cite the need for additional capabilities, including \_\_\_\_\_
  - a) Improved data storage and information retrieval
  - b) Improved extract, transform and load features for data integration
  - c) Improved data warehousing functionality
  - d) Improved security, workload management and SQL support
2. Point out the correct statement.
  - a) Hadoop do need specialized hardware to process the data
  - b) Hadoop 2.0 allows live stream processing of real time data
  - c) In Hadoop programming framework output files are divided into lines or records
  - d) None of the mentioned
3. According to analysts, for what can traditional IT systems provide a foundation when they're integrated with big data technologies like Hadoop?
  - a) Big data management and data mining
  - b) Data warehousing and business intelligence
  - c) Management of Hadoop clusters
  - d) Collecting and storing unstructured data
4. Hadoop is a framework that works with a variety of related tools. Common cohorts include \_\_\_\_\_
  - a) MapReduce, Hive and HBase
  - b) MapReduce, MySQL and Google Apps
  - c) MapReduce, Hummer and Iguana
  - d) MapReduce, Heron and Trumpet
5. Point out the wrong statement.
  - a) Hadoop processing capabilities are huge and it's real advantage lies in the ability to process terabytes & petabytes of data
  - b) Hadoop uses a programming model called "MapReduce", all the programs should confirm to this model in order to work on Hadoop platform
  - c) The programming model, MapReduce, used by Hadoop is difficult to write and test
  - d) All of the mentioned
6. What was Hadoop named after?
  - a) Creator Doug Cutting's favorite circus act
  - b) Cutting's high school rock band
  - c) The toy elephant of Cutting's son
  - d) A sound Cutting's laptop made during Hadoop development

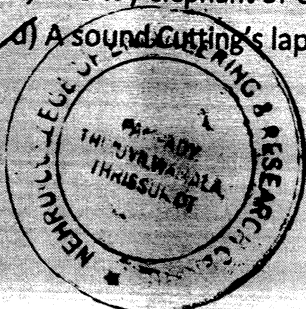

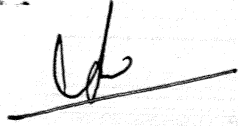
  
**PRINCIPAL**  
Nehru College of  
Engineering and Research Centre  
Pamapady, Thiruvilwamala, Thiruvananthapuram  
Pin: 680 597 Kerala



NEHRU COLLEGE OF ENGINEERING AND RESEARCH CENTRE  
(NAAC Accredited)

(Approved by AICTE, Affiliated to University of Calicut and APJ Abdul Kalam Technological University, Kerala)



1. All of the following accurately describe Hadoop, EXCEPT \_\_\_\_\_
- a) Open source
  - b) Real-time
  - c) Java-based
  - d) Distributed computing approach
2. \_\_\_\_\_ can best be described as a programming model used to develop Hadoop-based applications that can process massive amounts of data.
- a) MapReduce
  - b) Mahout
  - c) Oozie
  - d) All of the mentioned
3. \_\_\_\_\_ has the world's largest Hadoop cluster.
- a) Apple
  - b) Datamatics
  - c) Facebook
  - d) None of the mentioned
4. Facebook Tackles Big Data With \_\_\_\_\_ based on Hadoop.
- a) 'Project Prism'
  - b) 'Prism'
  - c) 'Project Big'
  - d) 'Project Data'
5. Replicated joins are useful for dealing with data skew.
- a) True
  - b) False
6. Maximum size allowed for small dataset in replicated join is:
- a) 10KB
  - b) 10 MB
  - c) 100 MB
  - d) 300 MB
7. Parameters could be passed to Pig scripts from:
- a) Parent Pig Scripts
  - b) Shell Script
  - c) Command Line
  - d) Configuration File
  - e) All the above except (a)
8. The schema of a relation can be examined through:
- a) ILLUSTRATE
  - b) DESCRIBE
  - c) DUMP
  - d) EXPLAIN

PRINCIPAL  
Nehru College of  
Engineering and Research Centre  
Pampady, Thiruvilwamala, Thrissur Dt  
Pin 680 597 Kerala



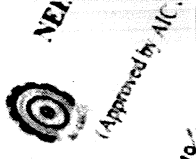

NEHRU COLLEGE OF ENGINEERING AND RESEARCH CENTRE  
(NAAC Accredited)

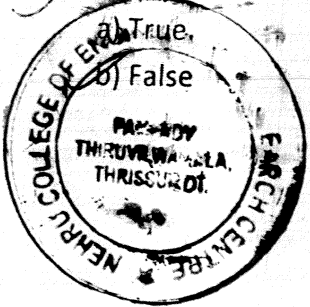

(Approved by AICTE, Affiliated to University of Calicut and APJ Abdul Kalam Technological University, Kerala)

40. Data can be loaded in HBase from Pig using
- a) PigStorage
  - b) SqoopStorage
  - c) BinStorage
  - d) HbaseStorage
41. Sqoop can load the data in HBase
- a) True
  - b) False
42. Which of the following APIs can be used for exploring HBase tables?
- a) HBaseDescriptor
  - b) HBaseAdmin
  - c) Configuration
  - d) HTable
43. Which of the following tables in HBase holds the region to key mapping?
- a) ROOT
  - b) .META.
  - c) MAP
  - d) REGIONS
44. What is the data type of version in HBase?
- a) INT
  - b) LONG
  - c) STRING
  - d) DATE
45. What is the data type of row key in HBase?
- a) INT
  - b) STRING
  - c) BYTE
  - d) BYTE[]
46. HBase first reads the data from
- a) Block Cache
  - b) Memstore
  - c) HFile
  - d) WAL
47. The High availability of Namenode is achieved in HDFS2.x using
- a) Polled Edit Logs
  - b) Synchronized Edit Logs
  - c) Shared Edit Logs
  - d) Edit Logs Replacement
48. The application master monitors all Map Reduce applications in the cluster
- a) True
  - b) False



  
PRINCIPAL  
Nehru College of  
Engineering and Research Centre  
Panipady, Thiruvilwamala, Thrisur Dt  
Pin 680 597 Kerala



NEHRU COLLEGE OF ENGINEERING AND RESEARCH CENTRE  
(NAAC Accredited)



(Approved by AICTE, Affiliated to University of Calicut and APJ Abdul Kalam Technological University, Kerala)

49. HDFS Federation is useful for the cluster size of:
- a) >500 nodes
  - b) >900 nodes
  - c) > 5000 nodes
  - d) > 3500 nodes
50. Hive managed tables stores the data in
- a) Local Linux path
  - b) Any HDFS path
  - c) HDFS warehouse path
  - d) None of the above
51. On dropping managed tables, Hive:
- a) Retains data, but deletes metadata
  - b) Retains metadata, but deletes data
  - c) Drops both, data and metadata
  - d) Retains both, data and metadata
52. Managed tables don't allow loading data from other tables.
- a) True b) False
53. External tables can load the data from warehouse Hive directory.
- a) True b) False
54. On dropping external tables, Hive:
- a) Retains data, but deletes metadata
  - b) Retains metadata, but deletes data
  - c) Drops both, data and metadata
  - d) Retains both, data and metadata
55. Partitioned tables can't load the data from normal (partitioned) tables
- a) True
  - b) False
56. The partitioned columns in Hive tables are
- a) Physically present and can be accessed
  - b) Physically absent but can be accessed
  - c) Physically present but can't be accessed
  - d) Physically absent and can't be accessed
57. Hive data models represent
- a) Table in Metastore DB
  - b) Table in HDFS
  - c) Directories in HDFS
  - d) None of the above
58. When is the earliest point at which the reduce method of a given Reducer can be called?
- A. As soon as at least one mapper has finished processing its input split.
  - B. As soon as a mapper has emitted at least one record.
  - C. Not until all mappers have finished processing all records.
  - D. It depends on the Input Format used for the job.

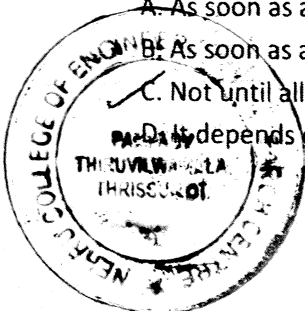

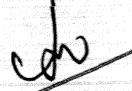
  
PRINCIPAL  
Nehru College of  
Engineering and Research Centre  
Pampady Thiruvilwamala, Thrissur Dt  
Pin 680 597 Kerala



NEHRU COLLEGE OF ENGINEERING AND RESEARCH CENTRE  
(NAAC Accredited)

(Approved by AICTE, Affiliated to University of Calicut and APJ Abdul Kalam Technological University, Kerala)

59. According to analysts, for what can traditional IT systems provide a foundation when they're integrated with big data technologies like Hadoop?
- A. Big data management and data mining
  - B. Data warehousing and business intelligence
  - C. Management of Hadoop clusters
  - D. Collecting and storing unstructured data
60. All of the following accurately describe Hadoop, EXCEPT:
- A. Open source
  - B. Real-time
  - C. Java-based
  - D. Distributed computing approach
61. \_\_\_\_\_ has the world's largest Hadoop cluster.
- A. Apple
  - B. Datamatics
  - C. Facebook
  - D. None of the mentioned
62. What are the five V's of Big Data?
- A. Volume
  - B. Velocity
  - C. Variety
  - D. All the above
63. \_\_\_\_\_ hides the limitations of Java behind a powerful and concise Clojure API for Cascading.
- A. Scalding
  - B. Cascalog
  - C. Hcatalog
  - D. Hcalding
64. Which of the following can be used to control the number of part files in a map reduce program output directory?
- a) Number of Mappers
  - b) Number of Reducers
  - c) Counter
  - d) Partitioner
65. Which of the following operations can't use Reducer as combiner also?
- a) Group by Minimum
  - b) Group by Maximum
  - c) Group by Count
  - d) Group by Average
66. Which of the following is/are true about combiners?
- a) Combiners can be used for mapper only job
  - b) Combiners can be used for any Map Reduce operation
  - c) Mappers can be used as a combiner class
  - d) Combiners are primarily aimed to improve Map Reduce performance
  - e) Combiners can't be applied for associative operations

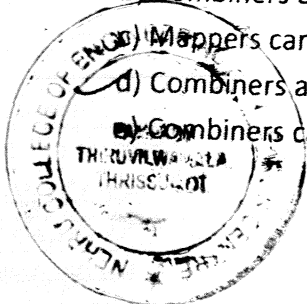

*[Handwritten Signature]*

PRINCIPAL  
Nehru College of  
Engineering and Research Centre  
Pampady Thiruvilwamala, Thrissur Dt  
Pin 680 597 Kerala



NEHRU COLLEGE OF ENGINEERING AND RESEARCH CENTRE  
(NAAC Accredited)



(Approved by AICTE, Affiliated to University of Calicut and APJ Abdul Kalam Technological University, Kerala)

67. Reduce side join is useful for
- a) Very large datasets
  - b) Very small data sets
  - c) One small and other big data sets
  - d) One big and other small datasets
68. Distributed Cache can be used in
- a) Mapper phase only
  - b) Reducer phase only
  - c) In either phase, but not on both sides simultaneously
  - d) In either phase
69. Counters persist the data on hard disk.
- a) True
  - b) False
70. What is optimal size of a file for distributed cache?
- a)  $\leq 10$  MB
  - b)  $\geq 250$  MB
  - c)  $\leq 100$  MB
  - d)  $\leq 35$  MB
71. Number of mappers is decided by the
- a) Mappers specified by the programmer
  - b) Available Mapper slots
  - c) Available heap memory
  - d) Input Splits
  - e) Input Format
72. Which of the following type of joins can be performed in Reduce side join operation?
- a) Equi Join
  - b) Left Outer Join
  - c) Right Outer Join
  - d) Full Outer Join
  - e) All of the above
73. What should be an upper limit for counters of a Map Reduce job?
- a) ~5s
  - b) ~15
  - c) ~150
  - d) ~50
74. Which of the following class is responsible for converting inputs to key-value Pairs of Map

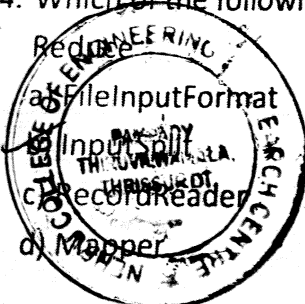

*Ch*

PRINCIPAL  
Nehru College of  
Engineering and Research Centre  
Panampady, Thiruvilwamala, Thrissur Dt  
Pin 680 597 Kerala



**NEHRU COLLEGE OF ENGINEERING AND RESEARCH CENTRE**  
(NAAC Accredited)

(Approved by AICTE, Affiliated to University of Calicut and APJ Abdul Kalam Technological University, Kerala)

75. Which of the following writables can be used to know value from a mapper/reducer?  
a) Text  
b) IntWritable  
c)  NullWritable  
d) String
76. Distributed cache files can't be accessed in Reducer.  
a) True  
b)  False
77. Only one distributed cache file can be used in a Map Reduce job.  
a) True  
b)  False
78. A Map reduce job can be written in:  
a) Java  
b) Ruby  
c) Python  
d)  Any Language which can read from input stream
79. Pig is a:  
a) Programming Language  
b)  Data Flow Language  
c) Query Language  
d) Database
80. Pig is good for:  
a) Data Factory operations  
b) Data Warehouse operations  
c)  Implementing complex SQLs  
d) Creating multiple datasets from a single large dataset  
e) Both (a) and (d)
81. Pig can be used for real-time data updates.  
a)  True  
b) False
82. Pig jobs have the same run time as the native Map Reduce jobs.  
a) True  
b)  False
83. Which of the following is the correct representation to access "Skill" from the Bag {'Skills', 55, ('Skill', 'Speed'), {2, ('San', 'Mateo')}}  
a)  \$3.\$1  
b) \$3.\$0  
c) \$2.\$0

84. NameNode tries to keep the first copy of data nearest to the client machine.

- a)  Always True  
b)  Always False

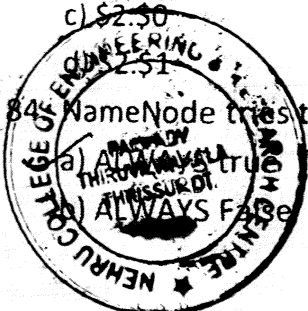

**ABIN CHAN**  
Nehru College of  
Engineering and Research Centre  
Pampady, Thiruvilwamala, Thirsur Dt  
Pin 680 597 Kerala

NEHRU COLLEGE OF ENGINEERING AND RESEARCH CENTRE  
(NAAC Accredited)



(Approved by AICTE, Affiliated to University of Calicut and APJ Abdul Kalam Technological University, Kerala)

- c) True if the client machine is the part of the cluster  
d) True if the client machine is not the part of the cluster
85. HDFS data blocks can be read in parallel.  
a) TRUE  
b) FALSE
86. Where is HDFS replication factor controlled?  
a) mapred-site.xml  
b) yarn-site.xml  
c) core-site.xml  
d) hdfs-site.xml
87. Read the statement and select the correct option:  
It is necessary to default all the properties in Hadoop config files.  
a) True  
b) False
88. Which of the following Hadoop config files is used to define the heap size?  
a) hdfs-site.xml  
b) core-site.xml  
c) hadoop-env.sh  
d) Slaves
89. Which of the following is not a valid Hadoop config file?  
a) mapred-site.xml  
b) hadoop-site.xml  
c) core-site.xml  
d) Masters
90. Read the statement:  
NameNodes are usually high storage machines in the clusters.  
a) True  
b) False  
c) Depends on cluster size  
d) True if co-located with Job tracker
91. From the options listed below, select the suitable data sources for flume.  
a) Publicly open web sites  
b) Local data folders  
c) Remote web servers  
d) Both (a) and (c)

92. Read the statement and select the correct options:

distcp command ALWAYS needs fully qualified hdfs paths.

- a) True  
b) False  
c) True, if source and destination are in same cluster  
d) False, if source and destination are in same cluster

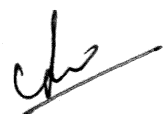
  
PRINCIPAL  
Nehru College of  
Engineering and Research Centre  
Pampady Thiruvilwamala, Thrissur Dt  
Pin 680 597 Kerala





NEHRU COLLEGE OF ENGINEERING AND RESEARCH CENTRE  
(NAAC Accredited)



(Approved by AICTE, Affiliated to University of Calicut and APJ Abdul Kalam Technological University, Kerala)

93. Which of following statement(s) are true about distcp command?
- a) It invokes MapReduce in background
  - b) It invokes MapReduce if source and destination are in same cluster
  - c) It can't copy data from local folder to hdfs folder
  - d) You can't overwrite the files through distcp command
94. Which of the following is NOT the component of Flume?
- a) Sink
  - b) Database
  - c) Source
  - d) Channel
95. Data can be supplied to PigUnit tests from:
- a) HDFS Location
  - b) Within Program
  - c) Both (a) and (b)
  - d) None of the above
96. Which of the following constructs are valid Pig Control Structures?
- a) If-else
  - b) For Loop
  - c) Until Loop
  - d) None of the above
97. Which of following is the return data type of Filter UDF?
- a) String
  - b) Integer
  - c) Boolean
  - d) None of the above
98. UDFs can be applied only in FOREACH statements in Pig.
- a) True
  - b) False
99. Which of the following are not possible in Hive?
- a) Creating Tables
  - b) Creating Indexes
  - c) Creating Synonym
  - d) Writing Update Statements
  - e) Both (c) and (d)
100. Who will initiate the mapper?

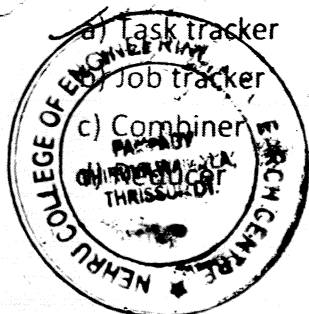

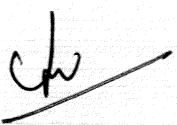
  
PRINCIPAL  
Nehru College of  
Engineering and Research Centre  
Panipady Thiruvilwamala, Thiruvananthapuram Dt  
Pin 680 597 Kerala

**NEHRU COLLEGE OF ENGINEERING AND RESEARCH CENTRE**  
(NAAC Accredited)

(Approved by AICTE, Affiliated to University of Calicut and APJ Abdul Kalam Technological University, Kerala)

**BIG DATA ANALYTICS USING HADOOP**

NAME:

REG NO:

62  
100

**ADD ON COURSE QUESTION PAPER**  
**DURATION: 2 HOURS**

1. As companies move past the experimental phase with Hadoop, many cite the need for additional capabilities, including \_\_\_\_\_
- a) Improved data storage and information retrieval
  - b) Improved extract, transform and load features for data integration
  - c) Improved data warehousing functionality
  - d) Improved security, workload management and SQL support
2. Point out the correct statement.
- a) Hadoop do need specialized hardware to process the data
  - b) Hadoop 2.0 allows live stream processing of real time data
  - c) In Hadoop programming framework output files are divided into lines or records
  - d) None of the mentioned
3. According to analysts, for what can traditional IT systems provide a foundation when they're integrated with big data technologies like Hadoop?
- a) Big data management and data mining
  - b) Data warehousing and business intelligence
  - c) Management of Hadoop clusters
  - d) Collecting and storing unstructured data
4. Hadoop is a framework that works with a variety of related tools. Common cohorts include \_\_\_\_\_
- a) MapReduce, Hive and HBase
  - b) MapReduce, MySQL and Google Apps
  - c) MapReduce, Hummer and Iguana
  - d) MapReduce, Heron and Trumpet
5. Point out the wrong statement.
- a) Hardtop processing capabilities are huge and it's real advantage lies in the ability to process terabytes & petabytes of data
  - b) Hadoop uses a programming model called "MapReduce", all the programs should confirms to this model in order to work on Hadoop platform
  - c) The programming model, MapReduce, used by Hadoop is difficult to write and test
  - d) All of the mentioned
6. What was Hadoop named after?
- a) Creator Doug Cutting's favorite circus act
  - b) Cutting's high school rock band
  - c) The toy elephant of Cutting's son
  - d) A sound Cutting's laptop made during Hadoop development

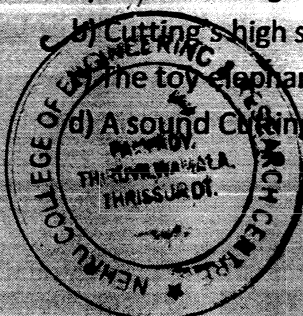

*[Signature]*  
**PRINCIPAL**  
Nehru College of  
Engineering and Research Centre  
Panipady Thiruvilwamala, Thirissur Dt  
Pin 680 597 Kerala



NEHRU COLLEGE OF ENGINEERING AND RESEARCH CENTRE  
(NAAC Accredited)

(Approved by AICTE, Affiliated to University of Calicut and APJ Abdul Kalam Technological University, Kerala)

7. All of the following accurately describe Hadoop, EXCEPT \_\_\_\_\_
- a) Open source
  - b) Real-time
  - c) Java-based
  - d) Distributed computing approach
8. \_\_\_\_\_ can best be described as a programming model used to develop Hadoop-based applications that can process massive amounts of data.
- a) MapReduce
  - b) Mahout
  - c) Oozie
  - d) All of the mentioned
9. \_\_\_\_\_ has the world's largest Hadoop cluster.
- a) Apple
  - b) Datamatics
  - c) Facebook
  - d) None of the mentioned
10. Facebook Tackles Big Data With \_\_\_\_\_ based on Hadoop.
- a) 'Project Prism'
  - b) 'Prism'
  - c) 'Project Big'
  - d) 'Project Data'
11. Replicated joins are useful for dealing with data skew.
- a) True
  - b) False
12. Maximum size allowed for small dataset in replicated join is:
- a) 10KB
  - b) 10 MB
  - c) 100 MB
  - d) 500 MB
13. Parameters could be passed to Pig scripts from:
- a) Parent Pig Scripts
  - b) Shell Script
  - c) Command Line
  - d) Configuration File
  - e) All the above except (a)
14. The schema of a relation can be examined through:
- a) ILLUSTRATE

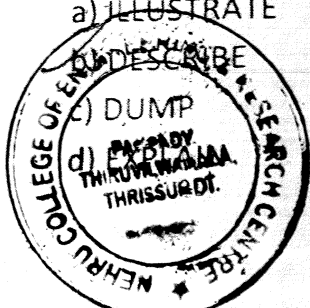

*Ch*

PRINCIPAL  
Nehru College of  
Engineering and Research Centre  
Panapady Thiruvilwamala, Thrissur Dt  
Pin: 680 597 Kerala



**NEHRU COLLEGE OF ENGINEERING AND RESEARCH CENTRE**  
(NAAC Accredited)

(Approved by AICTE, Affiliated to University of Calicut and APJ Abdul Kalam Technological University, Kerala)

15. DUMP Statement writes the output in a file.  
a) True  
b) False
16. Data can be supplied to PigUnit tests from:  
a) HDFS Location  
b) Within Program  
c) Both (a) and (b)  
d) None of the above
17. Which of the following constructs are valid Pig Control Structures?  
a) If-else  
b) For Loop  
c) Until Loop  
d) None of the above
18. Which of following is the return data type of Filter UDF?  
a) String  
b) Integer  
c) Boolean  
d) None of the above
19. UDFs can be applied only in FOREACH statements in Pig.  
a) True  
b) False
20. Which of the following are not possible in Hive?  
a) Creating Tables  
b) Creating Indexes  
c) Creating Synonym  
d) Writing Update Statements  
e) Both (c) and (d)
21. Who will initiate the mapper?  
a) Task tracker  
b) Job tracker  
c) Combiner  
d) Reducer
22. Which of the following are the Big Data Solutions Candidates?  
a) Processing 1.5 TB data everyday  
b) Processing 30 minutes Flight sensor data  
c) Interconnecting 50K data points (approx. 1 MB input file)  
d) Processing User clicks on a website  
e) All of the above
23. Hadoop is a framework that allows the distributed processing of:  
a) Small Data Sets  
b) Large Data Sets

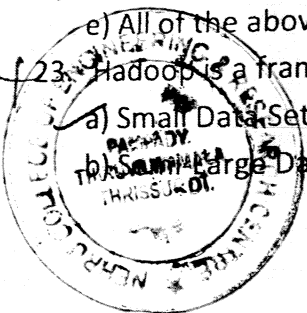

*Ch*  
**PRINCIPAL**  
Nehru College of  
Engineering and Research Centre  
Pampady Thiruviththala - TRASSUR Dt  
Pin 686 597 Kerala



NEHRU COLLEGE OF ENGINEERING AND RESEARCH CENTRE  
(NAAC Accredited)

(Approved by AICTE, Affiliated to University of Calicut and APJ Abdul Kalam Technological University, Kerala)

- c) Large Data Sets  
d) Large and Small Data sets
24. Where does Sqoop ingest data from?  
a) Linux File Directory  
 b) Oracle  
c) HBase  
d) MySQL  
e) MongoDB
25. Identify the batch processing scenarios from following:  
a) Sliding Window Averages Job  
b) Facebook Comments Processing Job  
 c) Inventory Dynamic Pricing Job  
d) Fraudulent Transaction Identification Job  
e) Financial Forecasting Job
26. Which of the following are NOT metadata items?  
a) List of HDFS files  
b) HDFS block locations  
 c) Replication factor of files  
d) Access Rights  
e) File Records distribution
27. What decides number of Mappers for a MapReduce job?  
a) File Location  
 b) mapred.map.tasks parameter  
c) Input file size  
d) Input Splits
28. Name Node monitors block replication process  
 a) TRUE  
b) FALSE  
c) Depends on file type
29. Which of the following are true for Hadoop Pseudo Distributed Mode?  
a) It runs on multiple machines  
b) Runs on multiple machines without any daemons  
 c) Runs on Single Machine with all daemons  
d) Runs on Single Machine without all daemons
30. Which of following statement(s) are correct?  
a) Master and slaves files are optional in Hadoop 2.x  
b) Master file has list of all name nodes  
 c) Core-site has hdfs and MapReduce related common properties  
 d) hdfs-site file is now deprecated in Hadoop 2.x
31. Which of the following is true for Hive?  
 a) Hive is the database of Hadoop  
 b) Hive supports schema checking

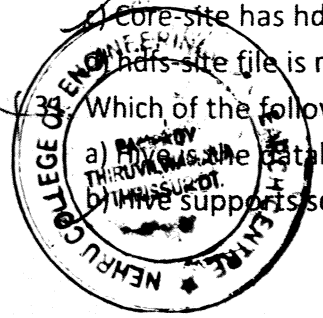

**PRINCIPAL**  
Nehru College of  
Engineering and Research Centre  
Pannady, Thiruvilwamala, Thiruvananthapuram Dt  
Pin - 680 597 Kerala

**NEHRU COLLEGE OF ENGINEERING AND RESEARCH CENTRE**  
(NAAC Accredited)

(Approved by AICTE, Affiliated to University of Calicut and APJ Abdul Kalam Technological University, Kerala)

SINCE 1968

- c) Hive doesn't allow row level updates  
d) Hive can replace an OLTP system
32. Which of the following is the highest level of Data Model in Hive?  
a) Table  
b) View  
c) Database  
d) Partitions
33. Hive queries response time is in order of  
a) Hours at least  
b) Minutes at least  
c) Seconds at least  
d) Milliseconds at least
34. Managed tables in Hive:  
a) Can load the data only from HDFS  
b) Can load the data only from local file system  
c) Are useful for enterprise wide data  
d) Are Managed by Hive for their data and metadata
35. Partitioned tables in Hive:  
a) Are aimed to increase the performance of the queries  
b) Modify the underlying HDFS structure  
c) Are not useful if the filter columns for query are different from the partition columns  
d) All of the above
36. Hive UDFs can only be written in Java  
a) True  
b) False
37. Hive can load the data from:  
a) Local File system  
b) HDFS File system  
c) Output of a Pig Job  
d) All of the above
38. HBase is a key/value store. Specifically it is:  
a) Sparse  
b) Sorted Map  
c) Distributed  
d) Consistent  
e) Multi-dimensional
39. Which of the following is the outer most part of HBase data model  
a) Database  
b) Table  
c) Row Key  
d) Column family

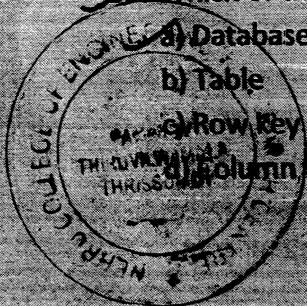

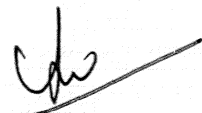
  
**PRINCIPAL**  
Nehru College of  
Engineering and Research Centre  
Pampady, Thiruvilwamala, Thiruvananthapuram Dt  
Pin - 680 597 Kerala



NEHRU COLLEGE OF ENGINEERING AND RESEARCH CENTRE  
(NAAC Accredited)

(Approved by AICTE, Affiliated to University of Calicut and APJ Abdul Kalam Technological University, Kerala)

40. Data can be loaded in HBase from Pig using
- a) PigStorage
  - b) SqoopStorage
  - c) BinStorage
  - d) HbaseStorage
41. Sqoop can load the data in HBase
- a) True
  - b) False
42. Which of the following APIs can be used for exploring HBase tables?
- a) HBaseDescriptor
  - b) HBaseAdmin
  - c) Configuration
  - d) HTable
43. Which of the following tables in HBase holds the region to key mapping?
- a) ROOT
  - b) .META.
  - c) MAP
  - d) REGIONS
44. What is the data type of version in HBase?
- a) INT
  - b) LONG
  - c) STRING
  - d) DATE
45. What is the data type of row key in HBase?
- a) INT
  - b) STRING
  - c) BYTE
  - d) BYTE[]
46. HBase first reads the data from
- a) Block Cache
  - b) Memstore
  - c) HFile
  - d) WAL
47. The High availability of Namenode is achieved in HDFS2.x using
- a) Polled Edit Logs
  - b) Synchronized Edit Logs
  - c) Shared Edit Logs
  - d) Edit Logs Replacement
48. The application master monitors all Map Reduce applications in the cluster
- a) True
  - b) False

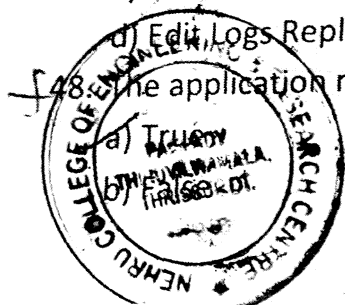

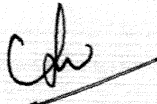
  
PRINCIPAL  
Nehru College of  
Engineering and Research Centre  
Pampady, Thiruvilwamala, Thiruvananthapuram Dt  
Pin - 680 597 Kerala



**NEHRU COLLEGE OF ENGINEERING AND RESEARCH CENTRE**  
(NAAC Accredited)

(Approved by AICTE, Affiliated to University of Calicut and APJ Abdul Kalam Technological University, Kerala)

49. HDFS Federation is useful for the cluster size of:
- a) >500 nodes
  - b) >900 nodes
  - c) > 5000 nodes
  - d) > 3500 nodes
50. Hive managed tables stores the data in
- a) Local Linux path
  - b) Any HDFS path
  - c) HDFS warehouse path
  - d) None of the above
51. On dropping managed tables, Hive:
- a) Retains data, but deletes metadata
  - b) Retains metadata, but deletes data
  - c) Drops both, data and metadata
  - d) Retains both, data and metadata
52. Managed tables don't allow loading data from other tables.
- a) True b) False
53. External tables can load the data from warehouse Hive directory.
- a) True b) False
54. On dropping external tables, Hive:
- a) Retains data, but deletes metadata
  - b) Retains metadata, but deletes data
  - c) Drops both, data and metadata
  - d) Retains both, data and metadata
55. Partitioned tables can't load the data from normal (partitioned) tables
- a) True
  - b) False
56. The partitioned columns in Hive tables are
- a) Physically present and can be accessed
  - b) Physically absent but can be accessed
  - c) Physically present but can't be accessed
  - d) Physically absent and can't be accessed
57. Hive data models represent
- a) Table in Metastore DB
  - b) Table in HDFS
  - c) Directories in HDFS
  - d) None of the above
58. When is the earliest point at which the reduce method of a given Reducer can be called?
- A. As soon as at least one mapper has finished processing its input split.
  - B. As soon as a mapper has emitted at least one record.
  - C. Not until all mappers have finished processing all records.
  - D. It depends on the Input Format used for the job.



  
**PRINCIPAL**  
Nehru College of  
Engineering and Research Centre  
Pattimada, Thiruvilwamala, Thiruvananthapuram Dt  
Pin 680 597 Kerala

**NEHRU COLLEGE OF ENGINEERING AND RESEARCH CENTRE**  
(NAAC Accredited)

(Approved by AICTE, Affiliated to University of Calicut and APJ Abdul Kalam Technological University, Kerala)

59. According to analysts, for what can traditional IT systems provide a foundation when they're integrated with big data technologies like Hadoop?
- A. Big data management and data mining
  - B. Data warehousing and business intelligence
  - C. Management of Hadoop clusters
  - D. Collecting and storing unstructured data
60. All of the following accurately describe Hadoop, EXCEPT:
- A. Open source
  - B. Real-time
  - C. Java-based
  - D. Distributed computing approach
61. \_\_\_\_\_ has the world's largest Hadoop cluster.
- A. Apple
  - B. Datamatics
  - C. Facebook
  - D. None of the mentioned
62. What are the five V's of Big Data?
- A. Volume
  - B. Velocity
  - C. Variety
  - D. All the above
63. \_\_\_\_\_ hides the limitations of Java behind a powerful and concise Clojure API for Cascading.
- A. Scalding
  - B. Cascalog
  - C. Hcatalog
  - D. Hcalding
64. Which of the following can be used to control the number of part files in a map reduce program output directory?
- a) Number of Mappers
  - b) Number of Reducers
  - c) Counter
  - d) Partitioner
65. Which of the following operations can't use Reducer as combiner also?
- a) Group by Minimum
  - b) Group by Maximum
  - c) Group by Count
  - d) Group by Average
66. Which of the following is/are true about combiners?
- a) Combiners can be used for mapper only job
  - b) Combiners can be used for any Map Reduce operation
  - c) Mappers can be used as a combiner class
  - d) Combiners are primarily aimed to improve Map Reduce performance
  - e) Combiners can't be applied for associative operations



  
**PRINCIPAL**  
Nehru College of  
Engineering and Research Centre  
Pampady Thiruvithamala, Thrissur Dt  
Pin 680 597 Kerala



NEHRU COLLEGE OF ENGINEERING AND RESEARCH CENTRE  
(NAAC Accredited)

(Approved by AICTE, Affiliated to University of Calicut and APJ Abdul Kalam Technological University, Kerala)

67. Reduce side join is useful for
- a) Very large datasets
  - b) Very small data sets
  - c) One small and other big data sets
  - d) One big and other small datasets
68. Distributed Cache can be used in
- a) Mapper phase only
  - b) Reducer phase only
  - c) In either phase, but not on both sides simultaneously
  - d) In either phase
69. Counters persist the data on hard disk.
- a) True
  - b) False
70. What is optimal size of a file for distributed cache?
- a)  $\leq 10$  MB
  - b)  $\geq 250$  MB
  - c)  $\leq 100$  MB
  - d)  $\leq 35$  MB
71. Number of mappers is decided by the
- a) Mappers specified by the programmer
  - b) Available Mapper slots
  - c) Available heap memory
  - d) Input Splits
  - e) Input Format
72. Which of the following type of joins can be performed in Reduce side join operation?
- a) Equi Join
  - b) Left Outer Join
  - c) Right Outer Join
  - d) Full Outer Join
  - e) All of the above
73. What should be an upper limit for counters of a Map Reduce job?
- a) ~5s
  - b) ~15
  - c) ~150
  - d) ~50
74. Which of the following class is responsible for converting inputs to key-value Pairs of Map

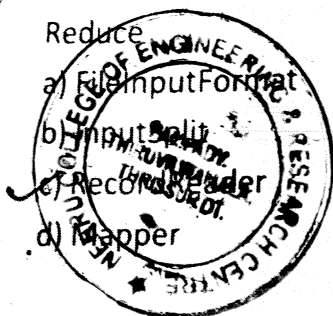

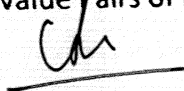
  
PRINCIPAL  
Nehru College of  
Engineering and Research Centre  
Panipady, Thiruvilwamala, Thirissur Dt  
Pin - 680 597 Kerala



NEHRU COLLEGE OF ENGINEERING AND RESEARCH CENTRE  
(NAAC Accredited)

(Approved by AICTE, Affiliated to University of Calicut and APJ Abdul Kalam Technological University, Kerala)

75. Which of the following writables can be used to know value from a mapper/reducer?  
a) Text  
b) IntWritable  
 c) NullWritable  
d) String
76. Distributed cache files can't be accessed in Reducer.  
a) True  
 b) False
77. Only one distributed cache file can be used in a Map Reduce job.  
 a) True  
b) False
78. A Map reduce job can be written in:  
a) Java  
 b) Ruby  
c) Python  
d) Any Language which can read from input stream
79. Pig is a:  
a) Programming Language  
b) Data Flow Language  
 c) Query Language  
d) Database
80. Pig is good for:  
a) Data Factory operations  
 b) Data Warehouse operations  
c) Implementing complex SQLs  
d) Creating multiple datasets from a single large dataset  
e) Both (a) and (d)
81. Pig can be used for real-time data updates.  
a) True  
 b) False
82. Pig jobs have the same run time as the native Map Reduce jobs.  
 a) True  
b) False
83. Which of the following is the correct representation to access "Skill" from the Bag (Skills, 55, ('Skill', 'Speed'), {2, ('San', 'Mateo')})  
 a) \$3.\$1  
b) \$3.\$0  
c) \$2.\$0  
d) \$2.\$1

MapReduce tries to keep the first copy of data nearest to the client machine.

- ALWAYS true  
 ALWAYS false

PRINCIPAL  
Nehru College of  
Engineering and Research Centre  
Panipady Thiruvilwamala, Thrissur Dt  
Pin 680 597 Kerala



NEHRU COLLEGE OF ENGINEERING AND RESEARCH CENTRE  
(NAAC Accredited)

(Approved by AICTE, Affiliated to University of Calicut and APJ Abdul Kalam Technological University, Kerala)

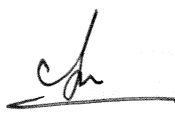

- c) True if the client machine is the part of the cluster  
d) True if the client machine is not the part of the cluster
85. HDFS data blocks can be read in parallel.  
a) TRUE  
b) FALSE
86. Where is HDFS replication factor controlled?  
a) mapred-site.xml  
b) yarn-site.xml  
c) core-site.xml  
d) hdfs-site.xml
87. Read the statement and select the correct option:  
It is necessary to default all the properties in Hadoop config files.  
a) True  
b) False
88. Which of the following Hadoop config files is used to define the heap size?  
a) hdfs-site.xml  
b) core-site.xml  
c) hadoop-env.sh  
d) Slaves
89. Which of the following is not a valid Hadoop config file?  
a) mapred-site.xml  
b) hadoop-site.xml  
c) core-site.xml  
d) Masters
90. Read the statement:  
NameNodes are usually high storage machines in the clusters.  
a) True  
b) False  
c) Depends on cluster size  
d) True if co-located with Job tracker
91. From the options listed below, select the suitable data sources for flume.  
a) Publicly open web sites  
b) Local data folders  
c) Remote web servers  
d) Both (a) and (c)
92. Read the statement and select the correct options:  
distcp command ALWAYS needs fully qualified hdfs paths.  
a) True  
b) False  
c) True, if source and destination are in same cluster  
d) False, if source and destination are in same cluster

  
PRINCIPAL  
Nehru College of  
Engineering and Research Centre  
Pampady Thiruvilwamala, Thrissur Dt  
Pin 680 597 Kerala



NEHRU COLLEGE OF ENGINEERING AND RESEARCH CENTRE  
(NAAC Accredited)

(Approved by AICTE, Affiliated to University of Calicut and APJ Abdul Kalam Technological University, Kerala)

93. Which of following statement(s) are true about distcp command?  
 a) It invokes MapReduce in background  
 b) It invokes MapReduce if source and destination are in same cluster  
 c) It can't copy data from local folder to hdfs folder  
 d) You can't overwrite the files through distcp command
94. Which of the following is NOT the component of Flume?  
 a) Sink  
 b) Database  
 c) Source  
 d) Channel
95. Data can be supplied to PigUnit tests from:  
 a) HDFS Location  
 b) Within Program  
 c) Both (a) and (b)  
 d) None of the above
96. Which of the following constructs are valid Pig Control Structures?  
 a) If-else  
 b) For Loop  
 c) Until Loop  
 d) None of the above
97. Which of following is the return data type of Filter UDF?  
 a) String  
 b) Integer  
 c) Boolean  
 d) None of the above
98. UDFs can be applied only in FOREACH statements in Pig.  
 a) True  
 b) False
99. Which of the following are not possible in Hive?  
 a) Creating Tables  
 b) Creating Indexes  
 c) Creating Synonym  
 d) Writing Update Statements  
 e) Both (c) and (d)
100. Who will initiate the mapper?  
 a) Task tracker  
 b) Job tracker  
 c) Combiner  
 d) Reducer

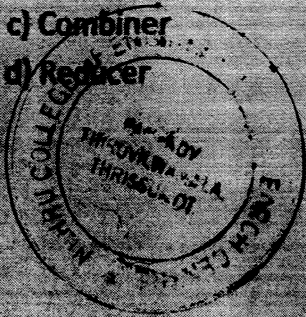

PRINCIPAL  
Nehru College of  
Engineering and Research Centre  
Paripady Thiruvilwamala, Thiruvananthapuram Dt  
Pin 686 507 Kerala



NEHRU COLLEGE OF ENGINEERING AND RESEARCH CENTRE  
(NAAC Accredited)

(Approved by AICTE, Affiliated to University of Calicut and APJ Abdul Kalam Technological University, Kerala)



**BIG DATA ANALYTICS USING HADOOP**

NAME:

REG NO:

GP  
100

ADD ON COURSE QUESTION PAPER  
DURATION: 2 HOURS

1. As companies move past the experimental phase with Hadoop, many cite the need for additional capabilities, including \_\_\_\_\_
  - a) Improved data storage and information retrieval
  - b) Improved extract, transform and load features for data integration
  - c) Improved data warehousing functionality
  - d) Improved security, workload management and SQL support
2. Point out the correct statement.
  - a) Hadoop do need specialized hardware to process the data
  - b) Hadoop 2.0 allows live stream processing of real time data
  - c) In Hadoop programming framework output files are divided into lines or records
  - d) None of the mentioned
3. According to analysts, for what can traditional IT systems provide a foundation when they're integrated with big data technologies like Hadoop?
  - a) Big data management and data mining
  - b) Data warehousing and business intelligence
  - c) Management of Hadoop clusters
  - d) Collecting and storing unstructured data
4. Hadoop is a framework that works with a variety of related tools. Common cohorts include \_\_\_\_\_
  - a) MapReduce, Hive and HBase
  - b) MapReduce, MySQL and Google Apps
  - c) MapReduce, Hummer and Iguana
  - d) MapReduce, Heron and Trumpet
5. Point out the wrong statement.
  - a) Hadoop processing capabilities are huge and it's real advantage lies in the ability to process terabytes & petabytes of data
  - b) Hadoop uses a programming model called "MapReduce", all the programs should confirms to this model in order to work on Hadoop platform
  - c) The programming model, MapReduce, used by Hadoop is difficult to write and test
  - d) All of the mentioned
6. What was Hadoop named after?
  - a) Creator Doug Cutting's favorite circus act
  - b) Cutting's high school rock band
  - c) The toy elephant of Cutting's son
  - d) A sound Cutting's laptop made during Hadoop development

Cdw

PRINCIPAL

Nehru College of  
Engineering and Research Centre  
Pampady Thiruvilwamala, Thrissur Dt  
Pin - 680 597, Kerala

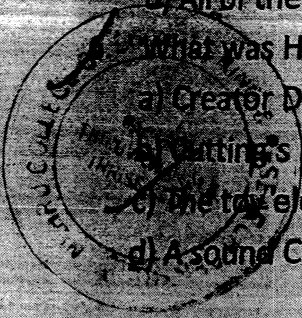



NEHRU COLLEGE OF ENGINEERING AND RESEARCH CENTRE  
(NAAC Accredited)

(Approved by AICTE, Affiliated to University of Calicut and APJ Abdul Kalam Technological University, Kerala)

SINCE 1964

7. All of the following accurately describe Hadoop, EXCEPT \_\_\_\_\_

- a) Open source
- b) Real-time
- c) Java-based
- d) Distributed computing approach

8. \_\_\_\_\_ can best be described as a programming model used to develop Hadoop-based applications that can process massive amounts of data.

- a) MapReduce
- b) Mahout
- c) Oozie
- d) All of the mentioned

9. \_\_\_\_\_ has the world's largest Hadoop cluster.

- a) Apple
- b) Datamatics
- c) Facebook
- d) None of the mentioned

10. Facebook Tackles Big Data With \_\_\_\_\_ based on Hadoop.

- a) 'Project Prism'
- b) 'Prism'
- c) 'Project Big'
- d) 'Project Data'

11. Replicated joins are useful for dealing with data skew.

- a) True
- b) False

12. Maximum size allowed for small dataset in replicated join is:

- a) 10KB
- b) 10 MB
- c) 100 MB
- d) 500 MB

13. Parameters could be passed to Pig scripts from:

- a) Parent Pig Scripts
- b) Shell Script
- c) Command Line
- d) Configuration File

14. All the above except (a)

15. The schema of a relation can be examined through:

- a) ILLUSTRATE
- b) DESCRIBE
- c) DUMP
- d) EXPLAIN



*Cdo*

PRINCIPAL  
Nehru College of  
Engineering and Research Centre  
Pampady Thiruvilwamala, Thrissur Dt  
Pin 680 597 Kerala

NEHRU COLLEGE OF ENGINEERING AND RESEARCH CENTRE  
(NAAC Accredited)

(Approved by AICTE, Affiliated to University of Calicut and APJ Abdul Kalam Technological University, Kerala)

Since 1968

15. DUMP Statement writes the output in a file.  
a) True  
b) False
16. Data can be supplied to PigUnit tests from:  
a) HDFS Location  
b) Within Program  
c) Both (a) and (b)  
d) None of the above
17. Which of the following constructs are valid Pig Control Structures?  
a) If-else  
b) For Loop  
c) Until Loop  
d) None of the above
18. Which of following is the return data type of Filter UDF?  
a) String  
b) Integer  
c) Boolean  
d) None of the above
19. UDFs can be applied only in FOREACH statements in Pig.  
a) True  
b) False
20. Which of the following are not possible in Hive?  
a) Creating Tables  
b) Creating Indexes  
c) Creating Synonym  
d) Writing Update Statements  
e) Both (c) and (d)
21. Who will initiate the mapper?  
a) Task tracker  
b) Job tracker  
c) Combiner  
d) Reducer
22. Which of the following are the Big Data Solutions Candidates?  
a) Processing 1.5 TB data everyday  
b) Processing 30 minutes Flight sensor data  
c) Interconnecting 50K data points (approx. 1 MB input file)  
d) Processing User clicks on a website  
e) All of the above

23. Hadoop is a framework that allows the distributed processing of:

- a) Small Data Sets  
b) Semi-Large Data Sets

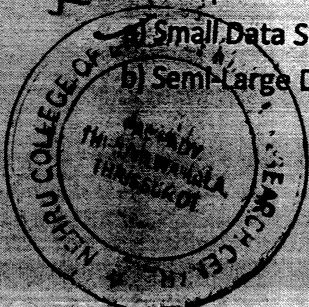

  
PRINCIPAL

Nehru College of  
Engineering and Research Centre  
Panpady Thiruvithamala, Thirissur Dt  
Pin 680 597 Kerala



**NEHRU COLLEGE OF ENGINEERING AND RESEARCH CENTRE**  
(NAAC Accredited)

(Approved by AICTE, Affiliated to University of Calicut and APJ Abdul Kalam Technological University, Kerala)

- c) Large Data Sets
- d) Large and Small Data sets
- + 24. Where does Sqoop ingest data from?
  - a) Linux File Directory
  - b) Oracle
  - c) HBase
  - + d) MySQL
  - e) MongoDB
- 25. Identify the batch processing scenarios from following:
  - a) Sliding Window Averages Job
  - b) Facebook Comments Processing Job
  - + c) Inventory Dynamic Pricing Job
  - d) Fraudulent Transaction Identification Job
  - e) Financial Forecasting Job
- 26. Which of the following are NOT metadata items?
  - a) List of HDFS files
  - b) HDFS block locations
  - c) Replication factor of files
  - d) Access Rights
  - + e) File Records distribution
- 27. What decides number of Mappers for a MapReduce job?
  - a) File Location
  - b) mapred.map.tasks parameter
  - + c) Input file size
  - d) Input Splits
- + 28. Name Node monitors block replication process
  - + a) TRUE
  - b) FALSE
  - c) Depends on file type
- + 29. Which of the following are true for Hadoop Pseudo Distributed Mode?
  - + a) It runs on multiple machines
  - b) Runs on multiple machines without any daemons
  - c) Runs on Single Machine with all daemons
  - d) Runs on Single Machine without all daemons
- 30. Which of following statement(s) are correct?
  - a) Master and slaves files are optional in Hadoop 2.x
  - b) Master file has list of all name nodes
  - c) Core-site has hdfs and MapReduce related common properties
  - d) hdfs-site file is now deprecated in Hadoop 2.x
- 31. Which of the following is true for Hive?
  - a) Hive is the database of Hadoop
  - b) Hive supports schema checking

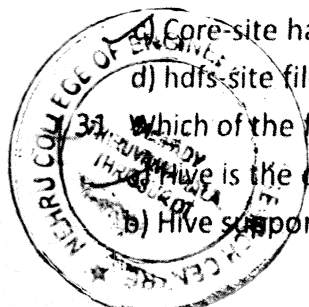

*C/h*

**PRINCIPAL**  
Nehru College of  
Engineering and Research Centre  
Pampady, Thiruvilwamala, Thrissur Dt  
Pin 680 597 Kerala

NEHRU COLLEGE OF ENGINEERING AND RESEARCH CENTRE  
(NAAC Accredited)

(Approved by AICTE, Affiliated to University of Calicut and APJ Abdul Kalam Technological University, Kerala)

- c) Hive doesn't allow row level updates  
d) Hive can replace an OLTP system
32. Which of the following is the highest level of Data Model in Hive?  
a) Table  
b) View  
c) Database  
d) Partitions
33. Hive queries response time is in order of  
a) Hours at least  
b) Minutes at least  
c) Seconds at least  
d) Milliseconds at least
34. Managed tables in Hive:  
a) Can load the data only from HDFS  
b) Can load the data only from local file system  
c) Are useful for enterprise wide data  
d) Are Managed by Hive for their data and metadata
35. Partitioned tables in Hive:  
a) Are aimed to increase the performance of the queries  
b) Modify the underlying HDFS structure  
c) Are not useful if the filter columns for query are different from the partition columns  
d) All of the above
36. Hive UDFs can only be written in Java  
a) True  
b) False
37. Hive can load the data from:  
a) Local File system  
b) HDFS File system  
c) Output of a Pig Job  
d) All of the above
38. HBase is a key/value store. Specifically it is:  
a) Sparse  
b) Sorted Map  
c) Distributed  
d) Consistent  
e) Multi-dimensional
39. Which of the following is the outer most part of HBase data model  
a) Database  
b) Table  
c) Row key  
d) Column family

  
PRINCIPAL  
Nehru College of  
Engineering and Research Centre  
Pampady Thiruvilwamala, Thirissur Dt  
Pin 680 597 Kerala



NEHRU COLLEGE OF ENGINEERING AND RESEARCH CENTRE  
(NAAC Accredited)

(Approved by AICTE, Affiliated to University of Calicut and APJ Abdul Kalam Technological University, Kerala)

40. Data can be loaded in HBase from Pig using  
a) PigStorage  
b) SqoopStorage  
c) BinStorage  
d) HbaseStorage
41. Sqoop can load the data in HBase  
a) True  
b) False
42. Which of the following APIs can be used for exploring HBase tables?  
a) HBaseDescriptor  
b) HBaseAdmin  
c) Configuration  
d) HTable
43. Which of the following tables in HBase holds the region to key mapping?  
a) ROOT  
b) META.  
c) MAP  
d) REGIONS
44. What is the data type of version in HBase?  
a) INT  
b) LONG  
c) STRING  
d) DATE
45. What is the data type of row key in HBase?  
a) INT  
b) STRING  
c) BYTE  
d) BYTE[]
46. HBase first reads the data from  
a) Block Cache  
b) Memstore  
c) HFile  
d) WAL
47. The High availability of Namenode is achieved in HDFS2.x using  
a) Polled Edit Logs  
b) Synchronized Edit Logs  
c) Shared Edit Logs  
d) Edit Logs Replacement
48. The application master monitors all Map Reduce applications in the cluster  
a) True  
b) False

PRINCIPAL  
Nehru College of  
Engineering and Research Centre  
Panipady Thiruvilwamala, Thirissur Dt  
Pin 680 597 Kerala

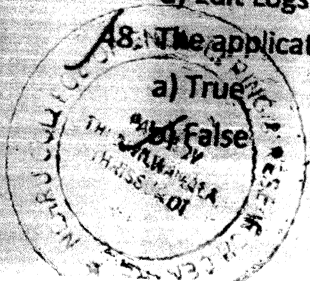

NEHRU COLLEGE OF ENGINEERING AND RESEARCH CENTRE  
(NAAC Accredited)

(Approved by AICTE, Affiliated to University of Calicut and APJ Abdul Kalam Technological University, Kerala)

49. HDFS Federation is useful for the cluster size of:
- a) >500 nodes
  - b) >900 nodes
  - c) > 5000 nodes
  - d) > 3500 nodes
50. Hive managed tables stores the data in
- a) Local Linux path
  - b) Any HDFS path
  - c) HDFS warehouse path
  - d) None of the above
51. On dropping managed tables, Hive:
- a) Retains data, but deletes metadata
  - b) Retains metadata, but deletes data
  - c) Drops both, data and metadata
  - d) Retains both, data and metadata
52. Managed tables don't allow loading data from other tables.
- a) True b) False
53. External tables can load the data from warehouse Hive directory.
- a) True  b) False
54. On dropping external tables, Hive:
- a) Retains data, but deletes metadata
  - b) Retains metadata, but deletes data
  - c) Drops both, data and metadata
  - d) Retains both, data and metadata
55. Partitioned tables can't load the data from normal (partitioned) tables
- a) True
  - b) False
56. The partitioned columns in Hive tables are
- a) Physically present and can be accessed
  - b) Physically absent but can be accessed
  - c) Physically present but can't be accessed
  - d) Physically absent and can't be accessed
57. Hive data models represent
- a) Table in Metastore DB
  - b) Table in HDFS
  - c) Directories in HDFS
  - d) None of the above
58. When is the earliest point at which the reduce method of a given Reducer can be called?
- A. As soon as at least one mapper has finished processing its input split.
  - B. As soon as a mapper has emitted at least one record.
  - C. Not until all mappers have finished processing all records.
  - D. It depends on the Input Format used for the job.

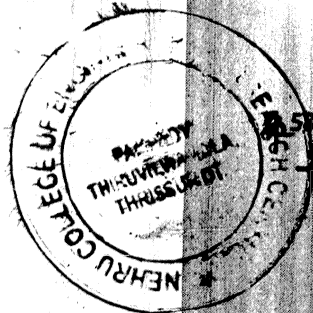

  
**PRINCIPAL**  
Nehru College of  
Engineering and Research Centre  
Pampady Thiruvilwamala, Thiruvananthapuram Dt  
Pin 680 597 Kerala



NEHRU COLLEGE OF ENGINEERING AND RESEARCH CENTRE  
(NAAC Accredited)

(Approved by AICTE, Affiliated to University of Calicut and APJ Abdul Kalam Technological University, Kerala)

59. According to analysts, for what can traditional IT systems provide a foundation when they're integrated with big data technologies like Hadoop?
- A. Big data management and data mining
  - B. Data warehousing and business intelligence
  - C. Management of Hadoop clusters
  - D. Collecting and storing unstructured data
60. All of the following accurately describe Hadoop, EXCEPT:
- A. Open source
  - B. Real-time
  - C. Java-based
  - D. Distributed computing approach
61. \_\_\_\_\_ has the world's largest Hadoop cluster.
- A. Apple
  - B. Datamatics
  - C. Facebook
  - D. None of the mentioned
62. What are the five V's of Big Data?
- A. Volume
  - B. Velocity
  - C. Variety
  - D. All the above
63. \_\_\_\_\_ hides the limitations of Java behind a powerful and concise Clojure API for Cascading.
- A. Scalding
  - B. Cascalog
  - C. Hcatalog
  - D. Hcalding
64. Which of the following can be used to control the number of part files in a map reduce program output directory?
- a) Number of Mappers
  - b) Number of Reducers
  - c) Counter
  - d) Partitioner
65. Which of the following operations can't use Reducer as combiner also?
- a) Group by Minimum
  - b) Group by Maximum
  - c) Group by Count
  - d) Group by Average
66. Which of the following is/are true about combiners?
- a) Combiners can be used for mapper only job
  - b) Combiners can be used for any Map Reduce operation
  - c) Mappers can be used as a combiner class
  - d) Combiners are primarily aimed to improve Map Reduce performance
  - e) Combiners can't be applied for associative operations

PRINCIPAL

Nehru College of  
Engineering and Research Centre  
Thiruvithamala, Thrissur Dt  
Pin - 680 597 Kerala



**NEHRU COLLEGE OF ENGINEERING AND RESEARCH CENTRE**  
(NAAC Accredited)

(Approved by AICTE, Affiliated to University of Calicut and APJ Abdul Kalam Technological University, Kerala)

Since 1966

- 67. Reduce side join is useful for
  - a) Very large datasets
  - b) Very small data sets
  - c) One small and other big data sets
  - d) One big and other small datasets
- 68. Distributed Cache can be used in
  - a) Mapper phase only
  - b) Reducer phase only
  - c) In either phase, but not on both sides simultaneously
  - d) In either phase
- +69. Counters persist the data on hard disk.
  - a) True
  - b) False
- +70. What is optimal size of a file for distributed cache?
  - a)  $\leq 10$  MB
  - b)  $\geq 250$  MB
  - c)  $\leq 100$  MB
  - d)  $\leq 35$  MB
- 71. Number of mappers is decided by the
  - a) Mappers specified by the programmer
  - b) Available Mapper slots
  - c) Available heap memory
  - d) Input Splits
  - e) Input Format
- 72. Which of the following type of joins can be performed in Reduce side join operation?
  - a) Equi Join
  - b) Left Outer Join
  - c) Right Outer Join
  - d) Full Outer Join
  - e) All of the above
- +73. What should be an upper limit for counters of a Map Reduce job?
  - a) ~5s
  - b) ~15
  - c) ~150
  - d) ~50

74. Which of the following class is responsible for converting inputs to key-value Pairs of Map

- Reduce
- a) FileInputFormat
- b) InputSplit
- c) RecordReader
- d) Mapper

**PRINCIPAL**  
Nehru College of  
Engineering and Research Centre  
Pampady, Thiruvilwamala, Thrissur Dt  
Pin 680 597 Kerala

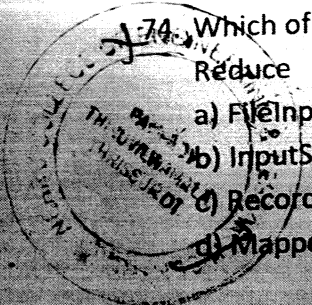



**NEHRU COLLEGE OF ENGINEERING AND RESEARCH CENTRE**  
(NAAC Accredited)

(Approved by AICTE. Affiliated to University of Calicut and APJ Abdul Kalam Technological University, Kerala)

75. Which of the following writables can be used to know value from a mapper/reducer?  
a) Text  
b) IntWritable  
c)  NullWritable  
d) String

76. Distributed cache files can't be accessed in Reducer.  
a)  True  
b) False

77. Only one distributed cache file can be used in a Map Reduce job.  
a)  True  
b) False

78. A Map reduce job can be written in:  
a)  Java  
b) Ruby  
c) Python  
d) Any Language which can read from input stream

79. Pig is a:  
a)  Programming Language  
b) Data Flow Language  
c) Query Language  
d) Database

80. Pig is good for:  
a) Data Factory operations  
b) Data Warehouse operations  
c) Implementing complex SQLs  
d) Creating multiple datasets from a single large dataset  
e)  Both (a) and (d)

81. Pig can be used for real-time data updates.  
a)  True  
b) False

82. Pig jobs have the same run time as the native Map Reduce jobs.  
a)  True  
b) False

83. Which of the following is the correct representation to access "Skill" from the Bag (['Skills', 55, ('Skill', 'Speed'), {2, ('San', 'Mateo')})

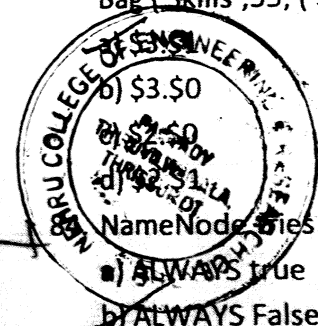

*[Signature]*  
**PRINCIPAL**  
Nehru College of  
Engineering and Research Centre  
Pampady, Thiruvilwamala, Thiruvārūr Dt  
Kerala. Pin 680 597

NameNode tries to keep the first copy of data nearest to the client machine. Pin 680 597 Kerala

a) ALWAYS true  
b) ALWAYS False

NEHRU COLLEGE OF ENGINEERING AND RESEARCH CENTRE  
(NAAC Accredited)

(Approved by AICTE, Affiliated to University of Calicut and APJ Abdul Kalam Technological University, Kerala)

- c) True if the client machine is the part of the cluster  
d) True if the client machine is not the part of the cluster
85. HDFS data blocks can be read in parallel.  
 a) TRUE  
 b) FALSE
86. Where is HDFS replication factor controlled?  
 a) mapred-site.xml  
 b) yarn-site.xml  
 c) core-site.xml  
 d) hdfs-site.xml
87. Read the statement and select the correct option:  
It is necessary to default all the properties in Hadoop config files.  
 a) True  
 b) False
88. Which of the following Hadoop config files is used to define the heap size?  
 a) hdfs-site.xml  
 b) core-site.xml  
 c) hadoop-env.sh  
 d) Slaves
89. Which of the following is not a valid Hadoop config file?  
 a) mapred-site.xml  
 b) hadoop-site.xml  
 c) core-site.xml  
 d) Masters
90. Read the statement:  
NameNodes are usually high storage machines in the clusters.  
 a) True  
 b) False  
 c) Depends on cluster size  
 d) True if co-located with Job tracker
91. From the options listed below, select the suitable data sources for flume.  
 a) Publicly open web sites  
 b) Local data folders  
 c) Remote web servers  
 d) Both (a) and (c)
92. Read the statement and select the correct options:  
distcp command ALWAYS needs fully qualified hdfs paths.  
 a) True  
 b) False  
 c) True, if source and destination are in same cluster  
 d) False, if source and destination are in same cluster

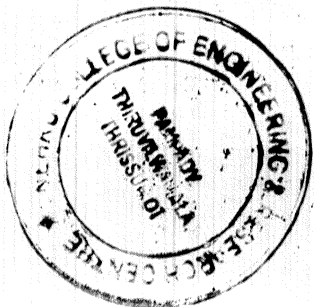

*Cab*  
PRINCIPAL  
Nehru College of  
Engineering and Research Centre  
Pampady, Thiruvilwamala, Thiruvananthapuram Dt  
Pin 680 597 Kerala



NEHRU COLLEGE OF ENGINEERING AND RESEARCH CENTRE  
(NAAC Accredited)

(Approved by AICTE, Affiliated to University of Calicut and APJ Abdul Kalam Technological University, Kerala)

Since 1984

93. Which of following statement(s) are true about distcp command?  
a) It invokes MapReduce in background  
b) It invokes MapReduce if source and destination are in same cluster  
c) It can't copy data from local folder to hdfs folder  
d) You can't overwrite the files through distcp command
94. Which of the following is NOT the component of Flume?  
a) Sink  
b) Database  
c) Source  
d) Channel
95. Data can be supplied to PigUnit tests from:  
a) HDFS Location  
b) Within Program  
c) Both (a) and (b)  
d) None of the above
96. Which of the following constructs are valid Pig Control Structures?  
a) If-else  
b) For Loop  
c) Until Loop  
d) None of the above
97. Which of following is the return data type of Filter UDF?  
a) String  
b) Integer  
c) Boolean  
d) None of the above
98. UDFs can be applied only in FOREACH statements in Pig.  
a) True  
b) False
99. Which of the following are not possible in Hive?  
a) Creating Tables  
b) Creating Indexes  
c) Creating Synonym  
d) Writing Update Statements  
e) Both (c) and (d)

100. Who will initiate the mapper?

- a) Task tracker  
b) Job tracker  
c) Combiner  
d) Reducer

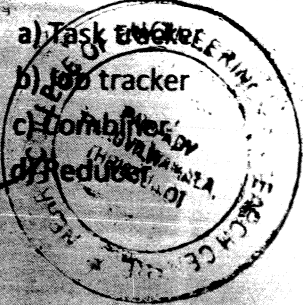

  
PRINCIPAL  
Nehru College of  
Engineering and Research Centre  
Panipady, Thiruvilwamala, Thirissur Dt  
Pin 680 597 Kerala

FROM

Ms. MARY MAREENA

ASSISTANT PROFESSOR

CSE DEPARTMENT, NCERC PAMPADY

TO

HEAD OF THE DEPARTMENT

CSE DEPARTMENT

NCERC PAMPADY

SUBJECT: Requisition for Conducting Add-On Course on "Big Data Analytics Using Hadoop"

Dear Sir,

As the Assistant Professor of Computer Science and Engineering, I would like to request your support and permission to conduct an Add On Course on "Big Data Analytics Using Hadoop" from 06-07-2015. It will be a 30-hour course scheduled for July to October of this year. It is therefore important for students to have a deep understanding of upcoming methodologies to enhance knowledge dissemination to students projects. This workshop will be very key as it will bring together all teachers and students in the department.

All UG/PG Engineering students of CSE Departments are Eligible for this course.

So, I kindly request you to provide the permission for doing this Add-On Course.

Thank you for your consideration. I look forward for your response soon.

Place: Pampady

Date: 01-07-2015

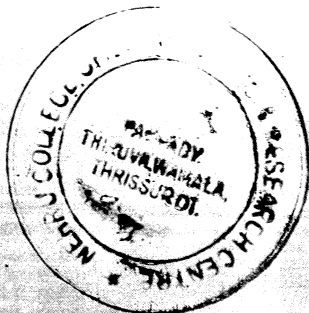

  
P.V.  
Sincerely

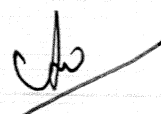
  
PRINCIPAL  
Nehru College of  
Engineering and Research Centre  
Pampady, Thiruvilwamala, Thrissur District  
Pin 680 597 Kerala



**NEHRU COLLEGE OF ENGINEERING AND RESEARCH CENTRE**  
(NAAC Accredited)  
(Approved by AICTE, Affiliated to University of Calicut and APJ Abdul Kalam Technological University, Kerala)



**ADMISSION TO ADD-ON COURSE (2015-2016)**

Applications are invited for admission for the Add-On Course 'Big Data Analytics using Hadoop' offered by the Department of Computer Science and Engineering, Nehru College of Engineering and Research Centre, Pampady, Thrissur.

**Eligibility Criteria:**

All UG/PG Engineering students of CSE department are Eligible.

Interested Students can give their names to respective class advisors on before 01-07-2015.

\*For First Years, Date is 05-08-2015.

**Timing:**

1 hour per day for 30 days from 4.00pm to 5.00pm. Saturday and Sunday may be used at the discretion of the Department.

**Attendance:**

A minimum of 75% attendance is required for writing the examination.

**Important Dates:**

Commencement of Classes: 06-07-2015

Examination date : 05-11-2015

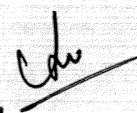

HOD   
PRINCIPAL  
Nehru College of  
Engineering and Research Centre  
Pampady, Thiruvilwamala, Thrissur District  
Pin 680 597 Kerala



**NEHRU COLLEGE OF ENGINEERING AND RESEARCH CENTRE**  
(NAAC Accredited)



(Approved by AICTE, Affiliated to University of Calicut and APJ Abdul Kalam Technological University, Kerala)

<b>BIG DATA ANALYTICS USING HADOOP syllabus</b>			
Module	Contents	Hours	Exam Marks
I	<p><b>INTRODUCTION TO BIG DATA</b> Introduction to Big Data: Why Big Data and Where did it come from? Characteristics of Big Data- Volume, Variety, Velocity, Veracity, Valence, Value, Challenges and applications of Big Data.</p> <p>Introduction to Big Data Platforms, Overview of Apache Spark, HDFS, YARN, Introduction to MapReduce, MapReduce Programming Model with Spark, MapReduce Example: Word Count, Page Rank etc</p>	10	30%
II	<p>Introduction to Big Data Storage Platforms for Large Scale Data Storage, CAP Theorem, Eventual Consistency, Consistency Trade-Offs, ACID and BASE.</p> <p>Introduction to Big Data Streaming Platforms for Fast Data, Introduction to Big Data Streaming Systems, Big Data Pipelines for Real-Time computing. Hive.</p>	10	30%

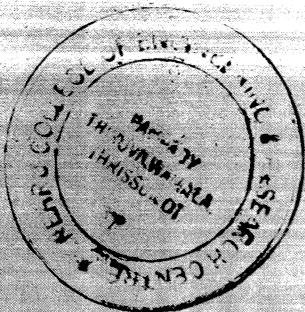

**PRINCIPAL**  
Nehru College of  
Engineering and Research Centre  
Pampady Thiruvilwamala, Thrissur Dt  
Pin - 680 597 Kerala



**NEHRU COLLEGE OF ENGINEERING AND RESEARCH CENTRE**  
(NAAC Accredited)



(Approved by AICTE, Affiliated to University of Calicut and APJ Abdul Kalam Technological University, Kerala)

15. DUMP Statement writes the output in a file.
- a) True
  - b) False
16. Data can be supplied to PigUnit tests from:
- a) HDFS Location
  - b) Within Program
  - c) Both (a) and (b)
  - d) None of the above
17. Which of the following constructs are valid Pig Control Structures?
- a) If-else
  - b) For Loop
  - c) Until Loop
  - d) None of the above
18. Which of the following is the return data type of Filter UDF?
- a) String
  - b) Integer
  - c) Boolean
  - d) None of the above
19. UDFs can be applied only in FOREACH statements in Pig.
- a) True
  - b) False
20. Which of the following are not possible in Hive?
- a) Creating Tables
  - b) Creating Indexes
  - c) Creating Synonym
  - d) Writing Update Statements
  - e) Both (c) and (d)
21. Who will initiate the mapper?
- a) Task tracker
  - b) Job tracker
  - c) Combiner
  - d) Reducer
22. Which of the following are the Big Data Solutions Candidates?
- a) Processing 1.5 TB data everyday
  - b) Processing 30 minutes Flight sensor data
  - c) Interconnecting 50K data points (approx. 1 MB input file)
  - d) Processing User clicks on a website
  - e) All of the above
23. Hadoop is a framework that allows the distributed processing of:
- a) Small Data Sets
  - b) Semi Large Data Sets

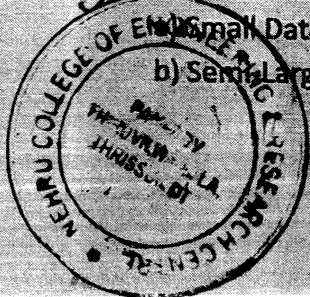

**PRINCIPAL**  
Nehru College of  
Engineering and Research Centre  
Pampady Thiruvilwamala, Thiruvananthapuram Dt.  
Pin 680 597 Kerala



# Certificate

## OF COMPLETION

PROUDLY PRESENTED TO

Arjun R Sekhar

For his/her Successful Completion on **BIG DATA ANALYTICS USING HADOOP** by, Department of Computer Science and Engineering, **Nehru College of Engineering and Research Centre, Pampady.**



  
PROGRAM  
CO-ORDINATOR

  
HEAD OF  
DEPARTMENT

PRINCIPAL  
Nehru College of  
Engineering and Research Centre  
Pampady, Thiruvilwamala, Thiruvananthapuram  
Pin - 680 597, Kerala



# Certificate OF COMPLETION

PROUDLY PRESENTED TO

Neha N S

For his/her Successful Completion on **BIG DATA ANALYTICS  
USING HADOOP** by, Department of Computer Science and  
Engineering, **Nehru College of Engineering and Research  
Centre, Pampady.**

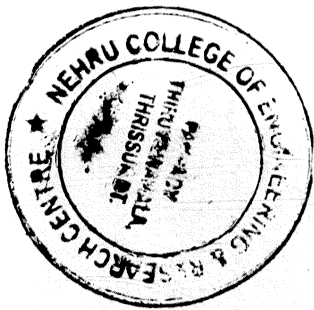

  
PROGRAM  
CO-ORDINATOR

  
HEAD OF  
DEPARTMENT PRINCIPAL

Nehru College of  
Engineering and Research Centre  
Pampady, Thiruvilwamala, Thiruvananthapuram, Dt.  
Pin - 680 507, Kerala



# Certificate OF COMPLETION

PROUDLY PRESENTED TO

Shafna S

For his/her Successful Completion on **BIG DATA ANALYTICS  
USING HADOOP** by, Department of Computer Science and  
Engineering, **Nehru College of Engineering and Research  
Centre, Pampady.**

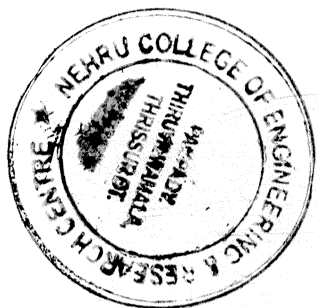

  
PROGRAM  
CO-ORDINATOR

  
HEAD OF  
DEPARTMENT

  
PRINCIPAL  
Nehru College of  
Engineering and Research Centre,  
Pampady, Thiruvilwamala, Thiruvananthapuram  
Pin 680 597 Kerala



# Certificate OF COMPLETION



PROUDLY PRESENTED TO

Sreeraj M

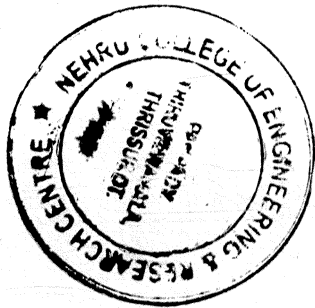
For his/her Successful Completion on **BIG DATA ANALYTICS  
USING HADOOP** by, Department of Computer Science and  
Engineering, **Nehru College of Engineering and Research  
Centre, Pampady.**



  
PROGRAM  
CO-ORDINATOR

  
HEAD OF  
DEPARTMENT 

PRINCIPAL  
Nehru College of  
Engineering and Research Centre,  
Pampady, Thiruvivamala, Thrissur District,  
Pin - 680 507 Kerala



**NEHRU COLLEGE OF ENGINEERING AND RESEARCH CENTRE  
(NAAC Accredited)**

(Approved by AICTE, Affiliated to APJ Abdul Kalam Technological University, Kerala)



# **Electrical and Electronics Engineering**



# Certificate OF COMPLETION

PROUDLY PRESENTED TO

Vishnu M

For his/her Successful Completion on **BIG DATA ANALYTICS  
USING HADOOP** by, Department of Computer Science and  
Engineering, **Nehru College of Engineering and Research  
Centre, Pampady.**

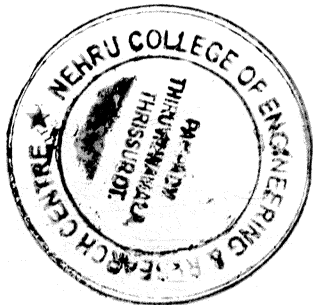

  
PROGRAM  
CO-ORDINATOR

  
HEAD OF  
DEPARTMENT

PRINCIPAL  
Nehru College of  
Engineering and Research Centre  
Pampady, Thiruvilwamala, Thirissur District

Pin - 686 557 Kerala

FROM,

MAHESWARAN K & RAJESH P,

ASSISTANT PROFESSOR(S),

EEE DEPARTMENT,

NCERC,

PAMPADY

TO,

THE PRINCIPAL,(THROUGH HOD)

EEE DEPARTMENT,

NCERC,

PAMPADY

Sir,

SUB: Requisition for conducting a certificate course on "ELECTRIC VEHICLE(FUTURE MOBILITY)"-  
Reg.

REF: Office circular No: NCERC/3128/F/AC/09/16 dt.12-07-2016

We would like to request your support and permission to conduct a certificate course on "ELECTRIC VEHICLE(FUTURE MOBILITY) " on second and fourth Saturdays of the academic year 2016-17 without affecting class work. The duration of the course will be for a period of 30 hours. The objective of the course is to impart knowledge on latest developments in electric vehicles in the upcoming future. This course will act as a key for enhancing know how of students on electric vehicles and for future career opportunities in that field.

The 2014-18 and 2015-19 batch admissions(UG) of EEE department are eligible for this course.

So, We kindly request you to provide the permission for doing this certificate course.

Thank you for your consideration. We look forward for your response soon.

PLACE: PAMPADY

DATE: 03/07/2016

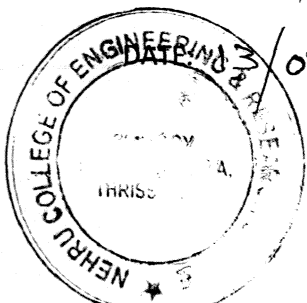

*Recommended & Forwarded*

*[Signature]*

*[Signature]*

Your's sincerely,

MAHESWARAN K

RAJESH P

*[Signature]*

*[Signature]*

PRINCIPAL  
Nehru College of  
Engineering and Research Centre  
Pampady Thiruvilwamala, Thrissur Dt

**NEHRU COLLEGE OF ENGINEERING & RESEARCH CENTRE**  
(Accredited by NAAC)  
**Pampady, Thiruvilwamala, Thrissur Dt.**

ELECTRICAL AND ELECTRONICS DEPARTMENT

NOTICE

12.07.2016

Department has decided to conduct a certificate course on "ELECTRIC VEHICLE(FUTURE MOBILITY)" on second and fourth Saturdays of the academic year 2016-17 without affecting class work. The duration of the course will be for a period of 30 hours. The objective of this course is to impart knowledge on latest developments in electric vehicles in the upcoming future. This course will act as a key for enhancing know how of students on electric vehicles and for future career opportunities in that field.

The 2014-18 and 2015-19 batch admissions(UG) of EEE department are eligible for this course. All concerned students should attend the entire course without fail. Attendance is compulsory.

Copy:

1. Department Notice Board
2. Staff advisors(For Information to students)
3. Office file

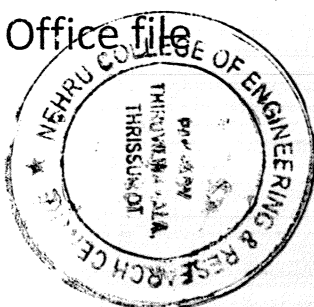

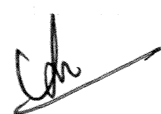
  
PRINCIPAL  
Nehru College of  
Engineering and Research Centre  
Pampady Thiruvilwamala Thrissur Dt  
686 507 Kerala

  
HoD

**NEHRU COLLEGE OF ENGINEERING & RESEARCH CENTRE**  
(Accredited by NAAC)  
Pampady, Thiruvilwamala, Thrissur Dt.

**EV(FUTURE MOBILITY)**

SYLLABUS

Lecture Modules	EV(FUTURE MOBILITY)
1	Introduction to Electric Vehicles
2	Working of Electric Vehicles Simulation of EV operation
3	
4	Applications of Electric Vehicles
5	Configurations of Electric Vehicles
6	Future of Electric Vehicles



Course Coordinator



HoD



  
**PRINCIPAL**  
Nehru College of  
Engineering and Research Centre  
Pampady, Thiruvilwamala, Thrissur Dt  
Pin 680 597 Kerala

**NEHRU COLLEGE OF ENGINEERING & RESEARCH CENTRE**  
(Accredited by NAAC)  
Pampady, Thiruvilwamala, Thrissur Dt.  
Certificate Course on "ELECTRIC VEHICLE(FUTURE MOBILITY) "  
Electrical & Electronics Engineering(UG) - (2014-18)Batch  
**ENROLLMENT LIST**

Reg.No.	Student Name
NCAOEEE001	Aakash M R
NCAOEEE002	Abhishek K.m
NCAOEEE003	Adarsh C
NCAOEEE005	Aiswarya Venu
NCAOEEE006	Ajas Muhammed K P
NCAOEEE007	Ajay Krishnan
NCAOEEE008	Ajay P
NCAOEEE009	Ajeesh C.g
NCAOEEE010	Ajesh S
NCAOEEE011	Akash Deepak
NCAOEEE012	Alisha Davis
NCAOEEE014	Anand P Menon
NCAOEEE015	Aneesh L
NCAOEEE016	Aparna Unni U.k
NCAOEEE017	Aqib T K
NCAOEEE018	Aravind R Pisharody
NCAOEEE020	Arun K G
NCAOEEE021	Arun Prakash
NCAOEEE022	Arun Raj
NCAOEEE023	Athul Kp
NCAOEEE024	Chandni A Shaji
NCAOEEE026	Dhanya Babu
NCAOEEE027	DILJU D

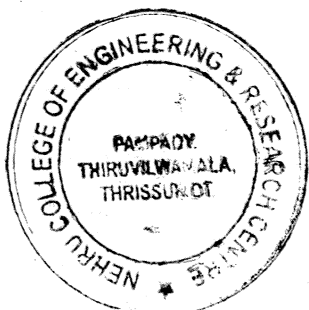

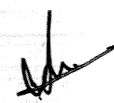
  
**PRINCIPAL**  
Nehru College of  
Engineering and Research Centre  
Pampady, Thiruvilwamala, Thrissur Dt.  
Pin 680 597 K...

NEHRU COLLEGE OF ENGINEERING & RESEARCH CENTRE  
(Accredited by NAAC)

Pampady, Thiruvilwamala, Thrissur Dt.  
Certificate Course on "ELECTRIC VEHICLE(FUTURE MOBILITY) "  
Electrical & Electronics Engineering(UG) - (2014-18)Batch  
ENROLLMENT LIST

NCAOEEE028	Giriprasoon P.t
NCAOEEE029	Hariprasad S
NCAOEEE030	Jijitha Mol R
NCAOEEE031	Justin D James
NCAOEEE032	Jyothilakshmi V R
NCAOEEE033	Keerthi Up
NCAOEEE034	Kiran M.k
NCAOEEE036	Mariya Paul
NCAOEEE037	Mithun R
NCAOEEE038	Muhammed Salman Faris K
NCAOEEE039	Muhammed Sharooq Ali
NCAOEEE040	Nikhil Babu
NCAOEEE041	Nithin K
NCAOEEE042	Pranav Ng
NCAOEEE043	Praveen N.m
NCAOEEE044	Preethi Ramadoss
NCAOEEE045	Rahul R
NCAOEEE046	Rosna S
NCAOEEE047	Sandeep Ks
NCAOEEE048	Sanjay Jayan
NCAOEEE049	Sarangi M V
NCAOEEE050	Sarath Janan.p
NCAOEEE051	Sarath Sathyan
NCAOEEE052	Satheesh M.b
NCAOEEE053	Sharang S Das
NCAOEEE054	Shyam Janan P
NCAOEEE055	Sidharth Krishnan
NCAOEEE056	Sivaprasad Sivadasan
NCAOEEE057	Saranju S.r
NCAOEEE059	Sunaina J
NCAOEEE060	Suraj J
NCAOEEE061	Tintu Mathew
NCAOEEE062	Vaisaghan P
NCAOEEE063	Vishnu K V
NCAOEEE064	Viswajith V
NCAOEEE065	Yadhukrishnan M S
NCAOEEE066	Ashiq Althaf
NCAOEEE067	Kishan K R
NCAOEEE068	Muhammed Raashid M V
NCAOEEE069	Minhaj Saifudheen

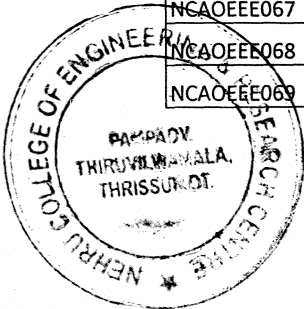

  
Course Coordinator

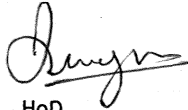
  
HoD

  
PRINCIPAL  
Nehru College of  
Engineering and Research Centre  
Pampady, Thiruvilwamala, Thrissur Dt.  
Pin - 686 507 Kerala

NCAOEEE034	Kiran M.k	/	/	/	/	/	/	/	/	/	/	/	/
NCAOEEE036	Mariya Paul	/	/	/	/	/	/	/	/	/	/	/	/
NCAOEEE037	Mithun R	/	/	/	/	/	/	/	/	/	/	/	/
NCAOEEE038	Muhammed Salman Faris K	/	/	/	/	/	/	/	/	/	/	/	/
NCAOEEE039	Muhammed Sharooq Ali	-A-	-A-	-A-	-A-	-A-	-A-	-A-	-A-	-A-	-A-	-A-	-A-
NCAOEEE040	Nikhil Babu	/	/	/	/	/	/	/	/	/	/	/	/
NCAOEEE041	Nithin K	/	/	/	/	/	/	/	/	/	/	/	/
NCAOEEE042	Pranav Ng	/	/	/	/	/	/	/	/	/	/	/	/
NCAOEEE043	Praveen N.m	/	/	/	/	/	/	/	/	/	/	/	/
NCAOEEE044	Preethi Ramadoss	/	/	/	/	/	/	/	/	/	/	/	/
NCAOEEE045	Rahul R	/	/	/	/	/	/	/	/	/	/	/	/
NCAOEEE046	Rosna S	/	/	/	/	/	/	/	/	/	/	/	/
NCAOEEE047	Sandeep Ks	/	/	/	/	/	/	/	/	/	/	/	/
NCAOEEE048	Sanjay Jayan	/	/	/	/	/	/	/	/	/	/	/	/
NCAOEEE049	Sarangi M V	/	/	/	/	/	/	/	/	/	/	/	/
NCAOEEE050	Sarath Janan.p	/	/	/	/	/	/	/	/	/	/	/	/
NCAOEEE051	Sarath Sathyan	/	/	/	/	/	/	/	/	/	/	/	/
NCAOEEE052	Satheesh M.b	/	/	/	/	/	/	/	/	/	/	/	/
NCAOEEE053	Sharang S Das	/	/	/	/	/	/	/	/	/	/	/	/
NCAOEEE054	Shyam Janan P	/	/	/	/	/	/	/	/	/	/	/	/
NCAOEEE055	Sidharth Krishnan	/	/	/	/	/	/	/	/	/	/	/	/
NCAOEEE056	Sivaprasad Sivadasan	/	/	/	/	/	/	/	/	/	/	/	/
NCAOEEE057	Saranju S.r	/	/	/	/	/	/	/	/	/	/	/	/
NCAOEEE059	Sunaina J	/	/	/	/	/	/	/	/	/	/	/	/
NCAOEEE060	Suraj J	/	/	/	/	/	/	/	/	/	/	/	/
NCAOEEE061	Tintu Mathew	/	/	/	/	/	/	/	/	/	/	/	/
NCAOEEE062	Vaisaghan P	/	/	/	/	/	/	/	/	/	/	/	/
NCAOEEE063	Vishnu K V	/	/	/	/	/	/	/	/	/	/	/	/
NCAOEEE064	Viswajith V	/	/	/	/	/	/	/	/	/	/	/	/
NCAOEEE065	Yadhukrishnan M S	/	/	/	/	/	/	/	/	/	/	/	/
NCAOEEE066	Ashiq Althaf	/	/	/	/	/	/	/	/	/	/	/	/
NCAOEEE067	Kishan K R	/	/	/	/	/	/	/	/	/	/	/	/
NCAOEEE068	Muhammed Raashid M V	/	/	/	/	/	/	/	/	/	/	/	/
NCAOEEE069	Minhaj Saifudheen	/	/	/	/	/	/	/	/	/	/	/	/

Course Coordinator

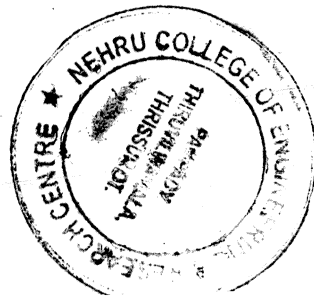

PRINCIPAL  
Nehru College of  
Engineering and Research Centre  
Pampady, Thiruvivamala, Thiruvananthapuram Dt  
Pin 630 597 Kerala

HoD

## NEHRU COLLEGE OF ENGINEERING & RESEARCH CENTRE

(Accredited by NAAC)

Pampady, Thiruvilwamala, Thrissur Dt.

Attendance Sheet for add-on course "ELECTRIC VEHICLE(FUTURE MOBILITY) "

Electrical & Electronics Engineering(UG) - (2014-18)Batch

Register Number	Name	23-07-2016		13-08-2016		27-08-2016		10-09-2016		24-09-2016		08-10-2016	
		FN	AN	FN	AN	FN	AN	FN	AN	FN	AN	FN	AN
NCAOEEE001	Aakash M R	/	/	/	/	/	/	/	/	/	/	/	/
NCAOEEE002	Abhishek K.m	/	/	/	/	/	/	/	/	/	/	/	/
NCAOEEE003	Adarsh C	/	/	/	/	/	/	/	/	/	/	/	/
NCAOEEE005	Aiswarya Venu	/	/	/	/	/	/	/	/	/	/	/	/
NCAOEEE006	Ajas Muhammed K P	/	/	/	/	/	/	/	/	/	/	/	/
NCAOEEE007	Ajay Krishnan	/	/	/	/	/	/	/	/	/	/	/	/
NCAOEEE008	Ajay P	/	/	/	/	/	/	/	/	/	/	/	/
NCAOEEE009	Ajeesh C.g	/	/	/	/	/	/	/	/	/	/	/	/
NCAOEEE010	Ajesh S	/	/	/	/	/	/	/	/	/	/	/	/
NCAOEEE011	Akash Deepak	/	/	/	/	/	/	/	/	/	/	/	/
NCAOEEE012	Alisha Davis	/	/	/	/	/	/	/	/	/	/	/	/
NCAOEEE014	Anand P Menon	/	/	/	/	/	/	/	/	/	/	/	/
NCAOEEE015	Aneesh L	/	/	/	/	/	/	/	/	/	/	/	/
NCAOEEE016	Aparna Unni U.k	/	/	/	/	/	/	/	/	/	/	/	/
NCAOEEE017	Aqib T K	/	/	/	/	/	/	/	/	/	/	/	/
NCAOEEE018	Aravind R Pisharody	/	/	/	/	/	/	/	/	/	/	/	/
NCAOEEE020	Arun K G	/	/	/	/	/	/	/	/	/	/	/	/
NCAOEEE021	Arun Prakash	/	/	/	/	/	/	/	/	/	/	/	/
NCAOEEE022	Arun Raj	/	/	/	/	/	/	/	/	/	/	/	/
NCAOEEE023	Athul Kp	/	/	/	/	/	/	/	/	/	/	/	/
NCAOEEE024	Chandni A Shaji	/	/	/	/	/	/	/	/	/	/	/	/
NCAOEEE026	Dhanya Babu	/	/	/	/	/	/	/	/	/	/	/	/
NCAOEEE027	DILJU D	/	/	/	/	/	/	/	/	/	/	/	/
NCAOEEE028	Giriprasoon P.t	/	/	/	/	/	/	/	/	/	/	/	/
NCAOEEE029	Hariprasad S	/	/	/	/	/	/	/	/	/	/	/	/
NCAOEEE030	Jijitha Mol R	/	/	/	/	/	/	/	/	/	/	/	/
NCAOEEE031	Justin D James	/	/	/	/	/	/	/	/	/	/	/	/
NCAOEEE032	thilakshmi V R	/	/	/	/	/	/	/	/	/	/	/	/
NCAOEEE033	karthi Up	/	/	/	/	/	/	/	/	/	/	/	/

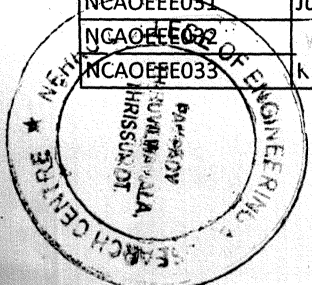

**PRINCIPAL**  
 Nehru College of  
 Engineering and Research Centre  
 Pampady, Thiruvilwamala, Thrissur Dt.

NEHRU COLLEGE OF ENGINEERING AND RESEARCH CENTRE  
(Accredited by NAAC)  
PAMPADY, THIRUVILWAMALA, THRISSUR (DT) – 680 588

EV-FUTURE MOBILITY

ANSWER KEY

Question No.	Answer	Question No.	Answer
1	a	16	b
2	c	17	c
3	c	18	a
4	d	19	d
5	b	20	c
6	b	21	c
7	c	22	c
8	a	23	a
9	a	24	d
10	c	25	b
11	b	26	a
12	d	27	a
13	a	28	c
14	d	29	d
15	c	30	b

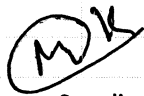

Course Coordinator

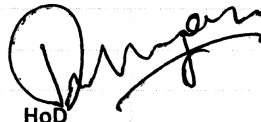

HoD

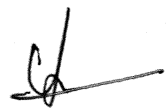
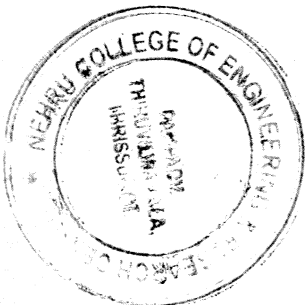

PRINCIPAL  
Nehru College of  
Engineering and Research Centre  
Pampady Thiruvilwamala, Thrissur Dt  
Pin - 680 597 Kerala



NEHRU COLLEGE OF ENGINEERING AND RESEARCH CENTRE  
(NAAC Accredited)

(Approved by AICTE, Affiliated to APJ Abdul Kalam Technological University, Kerala)



c). biodiesel and electric power

25. In a parallel hybrid:

- a). A gas engine runs an electric generator.
- b). A gas engine and electric motor can each turn the wheels.
- c). The engine has no connection to the transmissions

26. In a series hybrid:

- a). An electric motor acts as a backup to a gas engine.
- b). A gas engine and an electric motor alternately turn the wheels.
- c). A gas engine turns a generator, not the wheels.

27. Small engines are more efficient than large engines because:

- a). They weigh less.
- b). It takes less fuel to fill the cylinders.
- c). both A and B

28. In a Prius, the power split device connects the:

- a). gasoline engine, generator and electric motor
- b). gasoline engine, electric motor and power train
- c). gasoline engine, transmission and brakes

29. You should avoid abrupt stops in a hybrid car because:

- a). Hybrids are very sensitive to sudden changes in motion.
- b). The engine has more time to collect energy.
- c). Repairs to regenerative braking systems are extremely expensive.

30. This is the of Hybrid Electric Vehicles

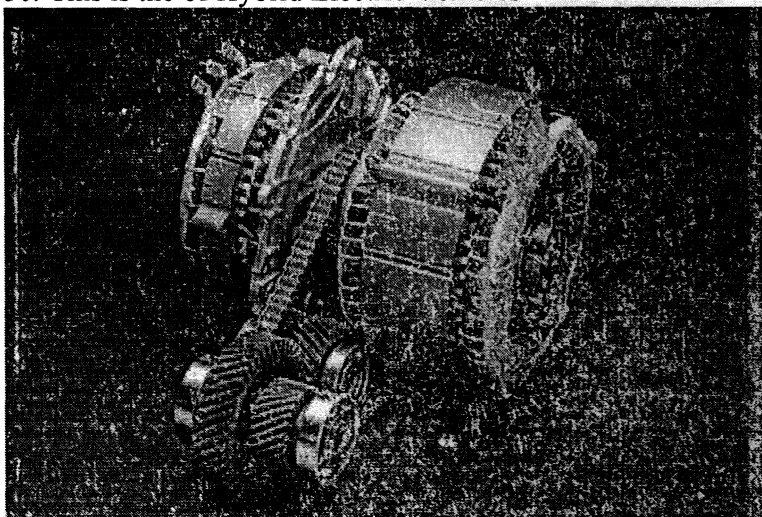

- a). Gearbox
- b). Motor Generator
- c). Automatic Transmission
- d). Engine

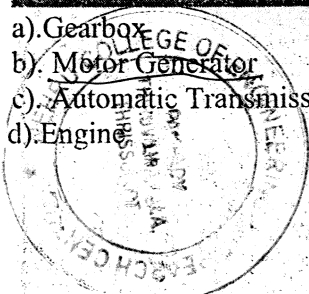

PRINCIPAL  
Nehru College of  
Engineering and Research Centre  
Pampady, Thiruvitthamala, Thiruvananthapuram Dt  
Pin 680 507 Kerala



NEHRU COLLEGE OF ENGINEERING AND RESEARCH CENTRE  
(NAAC Accredited)

(Approved by AICTE, Affiliated to APJ Abdul Kalam Technological University, Kerala)



18. The benefits of a hybrid car include :
- a). reducing emissions ✓
  - b). improving gas mileage
  - c). high fuel consumption
  - d). high speed driving
19. A \_\_\_\_\_ is a Hybrid source
- a). Mild Hybrid
  - b). Full Hybrid
  - c). Fuel Cell ✓
  - d). Assist Hybrid
20. A Toyota Prius C Hybrid has \_\_\_\_\_ engine.
- a). 1
  - b). 2
  - c). half ✓
  - d). no
21. Select the cycle use in a Hybrid Engine.
- a). Otto
  - b). Diesel
  - c). Atkinson ✓
  - d). Isentropic
22. Select the WRONG statement.
- a). Toyota produced the Insight Hybrid ✓
  - b). Hybrid systems rely on very high voltages
  - c). All of the high voltage cables are covered in orange sleeves for easy identification
  - d). To test high voltage systems you need a Category 3 (CAT III) digital volt ohmmeter
23. Select the CORRECT statement about Integrated Motor Assist (IMA) hybrid system
- a). Produced by Honda ✓
  - b). This system is the basis for many series parallel hybrid vehicles.
  - c). This system is capable of instantaneously switching from one power source to another or combining the two.
24. The most common type of hybrid car combines the following:
- a). diesel and electric power
  - b). gas and electric power

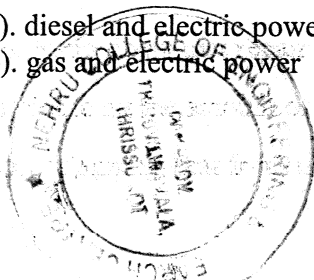

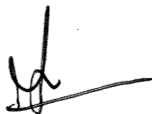
  
PRINCIPAL  
Nehru College of  
Engineering and Research Centre  
Pampady Taluk, Wayanad, Kerala Dt  
Pin - 630 597 Kerala



NEHRU COLLEGE OF ENGINEERING AND RESEARCH CENTRE  
(NAAC Accredited)

(Approved by AICTE, Affiliated to APJ Abdul Kalam Technological University, Kerala)



12. The Hybrid Electric Vehicle consists of :

- a) NGV engine + Gasoline engine
- b) IC engine + Gasoline engine
- c) Electric motor+ Electric motor
- d) IC engine+ Electric motor

13. "In this system, the engine is used to supply electrical power to the motor, which then turns the wheels" Select the type of Hybrid System according to above description.

- a) Series Hybrid
- b). Parallel Hybrid

c). Plug-in Hybrid

d). Series-parallel Hybrid

14. "The wheels are driven by both the engine and the motor" Select the type of Hybrid System according to above description.

a). Series Hybrid

b). Parallel Hybrid

c). Plug-in Hybrid

d). Series-parallel Hybrid

15. Select the features of Hybrid Electric Vehicles

a). Idle Stop

b). EV Drive

c). Regenerative braking

d). All the above.

16. The electric motor in a hybrid car can also act as :

a). cooling fan

b). fuel pump

c). generator

d). None of the above

17. Regenerative braking involves :

a). Nano fibers that repair the surface of brake pads

b). reducing the amount of friction necessary to slow a car

c). retaining heat from the brakes and using it for power

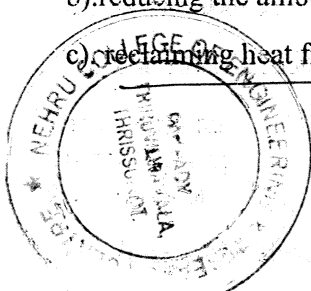



NEHRU COLLEGE OF ENGINEERING AND RESEARCH CENTRE  
(NAAC Accredited)

(Approved by AICTE, Affiliated to APJ Abdul Kalam Technological University, Kerala)



6. The MIL is illuminated and a "Battery Module Deterioration" diagnostic trouble code (DTC) is stored. The most likely cause is a failed:

- (A) high voltage battery.
- (B) high voltage inverter.
- (C) motor/generator.
- (D) DC/DC converter.

7. What purpose does a generator serve in a hybrid vehicle?

- It converts nuclear energy into more nuclear energy.
- It converts mechanical energy into electrical energy.
- It converts chemical energy into electrical energy.
- It converts electrical energy into mechanical energy.

8. What are the two main types of hybrid vehicle?

- The series hybrid vehicle and the mild hybrid vehicle.
- The parallel hybrid vehicle and the full hybrid vehicle.
- The series hybrid vehicle and the parallel hybrid vehicle.
- The full hybrid vehicle and the empty hybrid vehicle.

9. Which sentence best describes a parallel hybrid vehicle?

- The engine is directly connected to the transmission.
- The electric motor is directly connected to the transmission.
- Both of the above.
- None of the above.

10. Which of these is a purpose of the power-split device?

- To split electrical energy into mechanical energy.
- To allow both the engine and electric motor to propel the vehicle.
- To recharge the battery while braking.
- To recharge the brakes while driving.

11. which of the following is NOT the type of Hybrid Vehicle?

- a) Plug-in Hybrid
- b) Parallel Hybrid
- c) Natural Gas Fuel Vehicles
- d) Series Hybrid

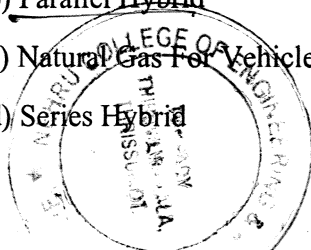



NEHRU COLLEGE OF ENGINEERING AND RESEARCH CENTRE  
(NAAC Accredited)

(Approved by AICTE, Affiliated to APJ Abdul Kalam Technological University, Kerala)



CERTIFICATION COURSE EXAM

CERTIFICATION COURSE NAME: Electric Vehicle (Future Mobility)

Time: 1 Hr

Marks: 30

Date: 08-10-16

Student Name: Gishan Krishna

Reg. No.: NCAOEE055

Department: Electrical And Electronics

1. A Electric vehicle equipped with push button start will enter the POWER ON mode, but will not enter the READY TO DRIVE mode. No diagnostic trouble codes (DTCs) are stored.

This could be caused by:

- (A) The high voltage safety plug is removed.
- (B) a failed brake on/off switch.
- (C) an empty fuel tank.
- (D) A 12 V battery which is disconnected

2. An electric vehicle equipped with a separate pump driven inverter cooling system has a diagnostic trouble code (DTC) for inverter overheating. The coolant is at the "full" level in the inverter coolant reservoir tank.

Technician A says that a failed inverter coolant pump could be the cause.

Technician B says that insufficient coolant in the internal combustion engine (ICE) cooling system could be the cause.

Who is right?

- (A) A only
- (B) B only
- (C) Both A and B.
- (D) Neither A nor B

3. A Type-1 hybrid vehicle will enter READY TO DRIVE (KOER) mode but will not crank the internal combustion engine (ICE). When the vehicle is pushed in NEUTRAL gear range, the engine spins. Which of these could be the cause?

- (A) A depleted high voltage battery
- (B) A seized MG2
- (C) A failed crankshaft position sensor
- (D) A seized planetary gear set

4. During deceleration, the arrows on the power flow display appear as shown. This indicates:

- (A) the engine is running with energy flowing to the drive wheels.
- (B) the engine is running and driving the motor/generator to recharge the battery pack.
- (C) energy from the battery pack and the engine are blended and flowing to the drive wheels.
- (D) energy from the drive wheels is being used to recharge the battery pack.

5. A Type-2 hybrid vehicle with a belt-type continuously variable transmission (CVT) bucks and jerks when accelerating from a stop.

Technician A says that using the wrong type of transmission fluid could be the cause.

Technician B says that a failing split pulley/steel belt could be the cause.

Who is right?

- A) A only (C) Both A and B
- (B) B only (D) Neither A nor B

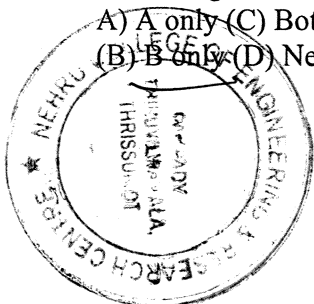



c). biodiesel and electric power

①

25. In a parallel hybrid:

- a). A gas engine runs an electric generator.
- b). A gas engine and electric motor can each turn the wheels.
- c). The engine has no connection to the transmissions

①

26. In a series hybrid:

- a). An electric motor acts as a backup to a gas engine.
- b). A gas engine and an electric motor alternately turn the wheels.
- c). A gas engine turns a generator, not the wheels.

①

27. Small engines are more efficient than large engines because:

- a). They weigh less.
- b). It takes less fuel to fill the cylinders.
- c). both A and B

①

28. In a Prius, the power split device connects the:

- a). gasoline engine, generator and electric motor
- b). gasoline engine, electric motor and power train
- c). gasoline engine, transmission and brakes

①

29. You should avoid abrupt stops in a hybrid car because:

- a). Hybrids are very sensitive to sudden changes in motion.
- b). The engine has more time to collect energy.
- c). Repairs to regenerative braking systems are extremely expensive.

①

30. This is the of Hybrid Electric Vehicles

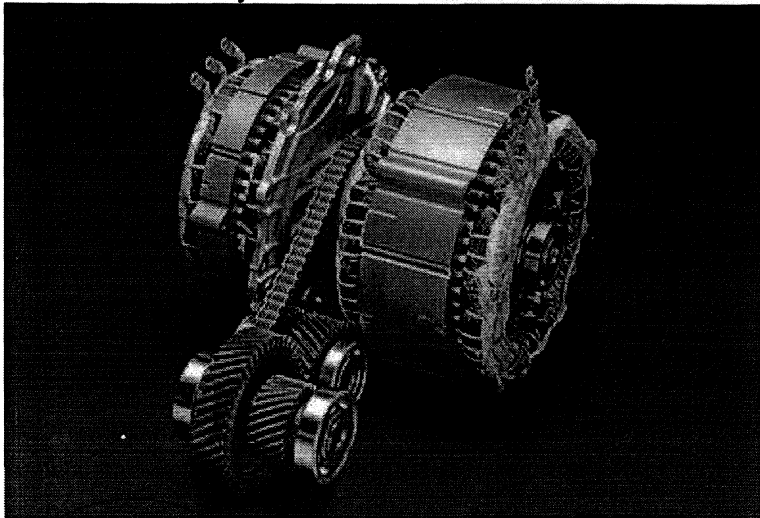

- a). Gearbox
- b). Motor Generator
- c). Automatic Transmission
- d). Engine

①

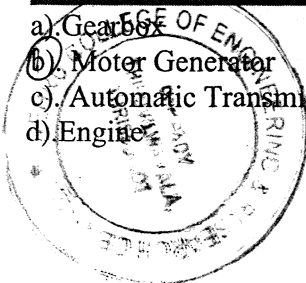



18. The benefits of a hybrid car include :

- a) reducing emissions
- b) improving gas mileage
- c) high fuel consumption
- d) high speed driving



1

19. A \_\_\_\_\_ is a Hybrid source

- a) Mild Hybrid
- b) Full Hybrid
- c) Fuel Cell
- d) Assist Hybrid



1

20. A Toyota Prius C Hybrid has \_\_\_\_\_ engine.

- a) 1
- b) 2
- c) half
- d) no



1

21. Select the cycle use in a Hybrid Engine.

- a) Otto
- b) Diesel
- c) Atkinson
- d) Isentropic

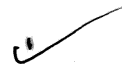

1

22. Select the WRONG statement.

- a) Toyota produced the Insight Hybrid
- b) Hybrid systems rely on very high voltages
- c) All of the high voltage cables are covered in orange sleeves for easy identification
- d) To test high voltage systems you need a Category 3 (CAT III) digital volt ohmmeter



1

23. Select the CORRECT statement about Integrated Motor Assist (IMA) hybrid system

- a) Produced by Honda
- b) This system is the basis for many series parallel hybrid vehicles.
- c) This system is capable of instantaneously switching from one power source to another or combining the two.

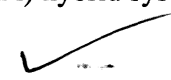

1

24. The most common type of hybrid car combines the following:

- a) diesel and electric power
- b) gas and electric power

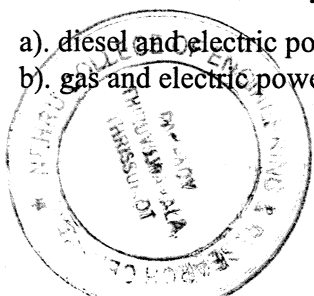



NEHRU COLLEGE OF ENGINEERING AND RESEARCH CENTRE  
(NAAC Accredited)

(Approved by AICTE, Affiliated to APJ Abdul Kalam Technological University, Kerala)



12. The Hybrid Electric Vehicle consists of :

- a) NGV engine + Gasoline engine
- b) IC engine + Gasoline engine
- c) Electric motor+ Electric motor
- d) IC engine+ Electric motor

✓ (1)

13. "In this system, the engine is used to supply electrical power to the motor, which then turns the wheels" Select the type of Hybrid System according to above description.

- a) Series Hybrid
- b). Parallel Hybrid
- c). Plug-in Hybrid
- d). Series-parallel Hybrid

✓ (1)

14. "The wheels are driven by both the engine and the motor" Select the type of Hybrid System according to above description.

- a). Series Hybrid
- b). Parallel Hybrid
- c). Plug-in Hybrid
- d). Series-parallel Hybrid

✓ (1)

15. Select the features of Hybrid Electric Vehicles

- a).Idle Stop
- b).EV Drive
- c). Regenerative braking
- d). All the above.

✓ (1)

16. The electric motor in a hybrid car can also act as :

- a).cooling fan
- b). fuel pump
- c).generator
- d). None of the above

✓ (1)

17. Regenerative braking involves :

- a). Nano fibers that repair the surface of brake pads
- b).reducing the amount of friction necessary to slow a car
- c).reclaiming heat from the brakes and using it for power

✓ (1)

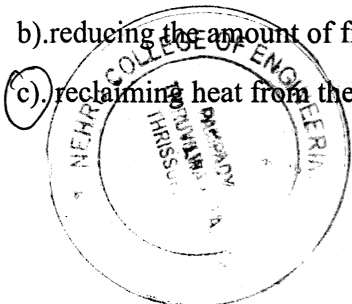

PRINCIPAL  
Nehru College of  
Engineering and Research Centre  
Pampady, Thiruvilwamala, Thiruvananthapuram Dt  
Pin . 680 597 Kerala



6. The MIL is illuminated and a "Battery Module Deterioration" diagnostic trouble code (DTC) is stored. The most likely cause is a failed:

- (A) high voltage battery.
- (B) high voltage inverter. X
- (C) motor/generator.
- (D) DC/DC converter. (0)

7. What purpose does a generator serve in a hybrid vehicle?

- (A) It converts nuclear energy into more nuclear energy.
- (B) It converts mechanical energy into electrical energy. (1)
- (C) It converts chemical energy into electrical energy. ✓
- (D) It converts electrical energy into mechanical energy.

8. What are the two main types of hybrid vehicle?

- (A) The series hybrid vehicle and the mild hybrid vehicle. (1)
- (B) The parallel hybrid vehicle and the full hybrid vehicle.
- (C) The series hybrid vehicle and the parallel hybrid vehicle.
- (D) The full hybrid vehicle and the empty hybrid vehicle. ✓

9. Which sentence best describes a parallel hybrid vehicle?

- (A) The engine is directly connected to the transmission. (1)
- (B) The electric motor is directly connected to the transmission.
- (C) Both of the above. ✓
- (D) None of the above.

10. Which of these is a purpose of the power-split device?

- (A) To split electrical energy into mechanical energy.
- (B) To allow both the engine and electric motor to propel the vehicle. (1)
- (C) To recharge the battery while braking. ✓
- (D) To recharge the brakes while driving.

11. which of the following is NOT the type of Hybrid Vehicle?

- a) Plug-in Hybrid
- b) Parallel Hybrid X
- (c) Natural Gas Fuel Vehicles (0)
- d) Series Hybrid ✓

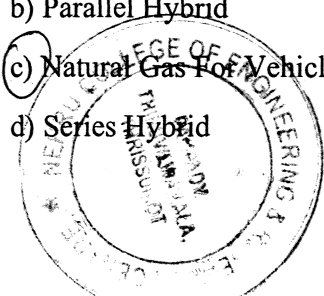

PRINCIPAL  
Nehru College of  
Engineering and Research Centre  
Pampady, Thiruvilwamala, Thrissur Dt  
Pin 680 597 Kerala



**NEHRU COLLEGE OF ENGINEERING AND RESEARCH CENTRE**  
(NAAC Accredited)

(Approved by AICTE, Affiliated to APJ Abdul Kalam Technological University, Kerala)



**CERTIFICATION COURSE EXAM**

**CERTIFICATION COURSE NAME: Electric Vehicle (Future Mobility)**

**Time: 1 Hr**

**Marks: 30**

**Date: 08-10-2016**

**Student Name: Malingapudh**

**Reg. No.:**

28  
30

NLADEEE036

**Department: Electrical And Electronics**

1. A Electric vehicle equipped with push button start will enter the POWER ON mode, but will not enter the READY TO DRIVE mode. No diagnostic trouble codes (DTCs) are stored. This could be caused by:

- (A) The high voltage safety plug is removed.
- (B) a failed brake on/off switch.
- (C) an empty fuel tank.
- (D) A 12 V battery which is disconnected

1

2. An electric vehicle equipped with a separate pump driven inverter cooling system has a diagnostic trouble code (DTC) for inverter overheating. The coolant is at the "full" level in the inverter coolant reservoir tank.

Technician A says that a failed inverter coolant pump could be the cause.

Technician B says that insufficient coolant in the internal combustion engine (ICE) cooling system could be the cause.

Who is right?

- (A) A only
- (B) B only
- (C) Both A and B
- (D) Neither A nor B

1

3. A Type-1 hybrid vehicle will enter READY TO DRIVE (KOER) mode but will not crank the internal combustion engine (ICE). When the vehicle is pushed in NEUTRAL gear range, the engine spins. Which of these could be the cause?

- (A) A depleted high voltage battery
- (B) A seized MG2
- (C) A failed crankshaft position sensor
- (D) A seized planetary gear set

1

4. During deceleration, the arrows on the power flow display appear as shown. This indicates:

- (A) the engine is running with energy flowing to the drive wheels.
- (B) the engine is running and driving the motor/generator to recharge the battery pack.
- (C) energy from the battery pack and the engine are blended and flowing to the drive wheels.
- (D) energy from the drive wheels is being used to recharge the battery pack.

1

5. A Type-2 hybrid vehicle with a belt-type continuously variable transmission (CVT) bucks and jerks when accelerating from a stop.

Technician A says that using the wrong type of transmission fluid could be the cause.

Technician B says that a failing split pulley/steel belt could be the cause.

Who is right?

- (A) A only (C) Both A and B
- (B) B only (D) Neither A nor B

1

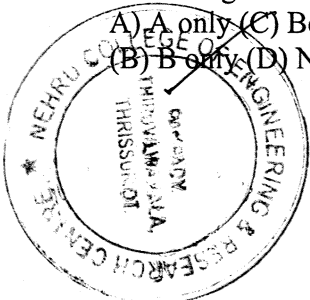

**PRINCIPAL**  
Nehru College of  
Engineering and Research Centre  
Panipady Thiruvilwamala, Thirsur Dt  
Pin 680 597 Kerala



**NEHRU COLLEGE OF ENGINEERING AND RESEARCH CENTRE**  
**(NAAC Accredited)**

(Approved by AICTE, Affiliated to APJ Abdul Kalam Technological University, Kerala)



c) biodiesel and electric power ✓

25. In a parallel hybrid:

- a). A gas engine runs an electric generator.
- b). A gas engine and electric motor can each turn the wheels ✓
- c). The engine has no connection to the transmissions

26. In a series hybrid:

- a). An electric motor acts as a backup to a gas engine. ✓
- b). A gas engine and an electric motor alternately turn the wheels.
- c). A gas engine turns a generator, not the wheels.

27. Small engines are more efficient than large engines because:

- a). They weigh less. ✓
- b). It takes less fuel to fill the cylinders.
- c). both A and B

28. In a Prius, the power split device connects the:

- a). gasoline engine, generator and electric motor ✓
- b). gasoline engine, electric motor and power train
- c). gasoline engine, transmission and brakes

29. You should avoid abrupt stops in a hybrid car because:

- a). Hybrids are very sensitive to sudden changes in motion. ✓
- b). The engine has more time to collect energy. ✓
- c). Repairs to regenerative braking systems are extremely expensive.

30. This is the of Hybrid Electric Vehicles

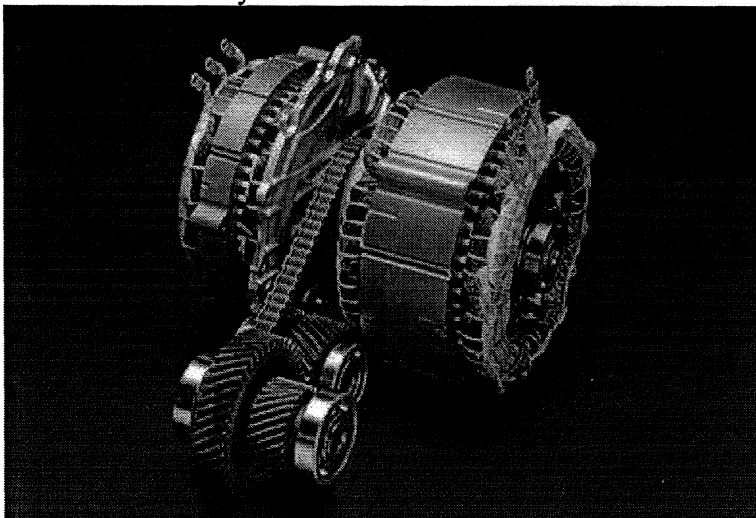

- a). Gearbox ✓
- b). Motor Generator
- c). Automatic Transmission
- d). Engine

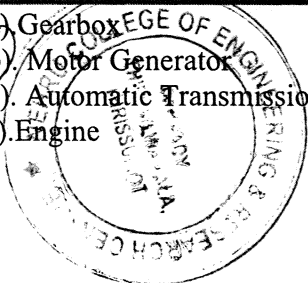



NEHRU COLLEGE OF ENGINEERING AND RESEARCH CENTRE  
(NAAC Accredited)

(Approved by AICTE, Affiliated to APJ Abdul Kalam Technological University, Kerala)



18. The benefits of a hybrid car include :

- a). reducing emissions
- b). improving gas mileage
- c). high fuel consumption
- d). high speed driving

19. A \_\_\_\_\_ is a Hybrid source

- a).Mild Hybrid
- b). Full Hybrid
- c). Fuel Cell
- d). Assist Hybrid

20. A Toyota Prius C Hybrid has \_\_\_\_\_ engine.

- a). 1
- b). 2
- c). half
- d). no

21. Select the cycle use in a Hybrid Engine.

- a). Otto
- b).Diesel
- c).Atkinson
- d). Isentropic

22. Select the WRONG statement.

- a). Toyota produced the Insight Hybrid
- b). Hybrid systems rely on very high voltages
- c). All of the high voltage cables are covered in orange sleeves for easy identification
- d). To test high voltage systems you need a Category 3 (CAT III) digital volt ohmmeter

23. Select the CORRECT statement about Integrated Motor Assist (IMA) hybrid system

- a). Produced by Honda
- b). This system is the basis for many series parallel hybrid vehicles.
- c). This system is capable of instantaneously switching from one power source to another or combining the two.

24. The most common type of hybrid car combines the following:

- a). diesel and electric power
- b). gas and electric power

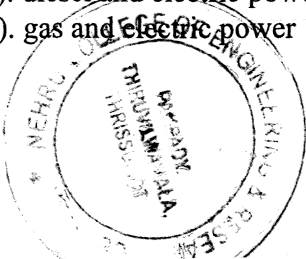



NEHRU COLLEGE OF ENGINEERING AND RESEARCH CENTRE  
(NAAC Accredited)

(Approved by AICTE, Affiliated to APJ Abdul Kalam Technological University, Kerala)



12. The Hybrid Electric Vehicle consists of :

- a) NGV engine + Gasoline engine
- b) IC engine + Gasoline engine ✓
- c) Electric motor+ Electric motor
- d) IC engine+ Electric motor

13. "In this system, the engine is used to supply electrical power to the motor, which then turns the wheels" Select the type of Hybrid System according to above description.

- a). Series Hybrid ✓
- b). Parallel Hybrid
- c). Plug-in Hybrid
- d). Series-parallel Hybrid

14. "The wheels are driven by both the engine and the motor" Select the type of Hybrid System according to above description.

- a). Series Hybrid
- b). Parallel Hybrid
- c). Plug-in Hybrid ✓
- d). Series-parallel Hybrid

15. Select the features of Hybrid Electric Vehicles

- a).Idle Stop
- b).EV Drive
- c) Regenerative braking ✓
- d). All the above.

16. The electric motor in a hybrid car can also act as :

- a).cooling fan
- b) fuel pump ✓
- c).generator
- d). None of the above

17. Regenerative braking involves :

- a). Nano fibers that repair the surface of brake pads
- b).reducing the amount of friction necessary to slow a car
- c). reclaiming heat from the brakes and using it for power ✓

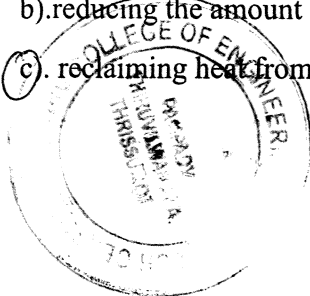

PRINCIPAL  
Nehru College of  
Engineering and Research Centre  
Panipady Thiruvilwamala, Thrissur Dt  
Pin 680 597 Kerala



6. The MIL is illuminated and a "Battery Module Deterioration" diagnostic trouble code (DTC) is stored. The most likely cause is a failed:

- (A) high voltage battery.
- (B) high voltage inverter.
- (C) motor/generator.
- (D) DC/DC converter.

7. What purpose does a generator serve in a hybrid vehicle?

- It converts nuclear energy into more nuclear energy.
- It converts mechanical energy into electrical energy.
- (D) It converts chemical energy into electrical energy. ✓
- It converts electrical energy into mechanical energy.

8. What are the two main types of hybrid vehicle?

- (D) The series hybrid vehicle and the mild hybrid vehicle. ✓
- The parallel hybrid vehicle and the full hybrid vehicle.
- The series hybrid vehicle and the parallel hybrid vehicle.
- The full hybrid vehicle and the empty hybrid vehicle.

9. Which sentence best describes a parallel hybrid vehicle?

- (D) The engine is directly connected to the transmission. ✓
- The electric motor is directly connected to the transmission.
- Both of the above.
- None of the above.

10. Which of these is a purpose of the power-split device?

- To split electrical energy into mechanical energy.
- To allow both the engine and electric motor to propel the vehicle.
- (D) To recharge the battery while braking. ✓
- To recharge the brakes while driving.

11. which of the following is NOT the type of Hybrid Vehicle?

- a) Plug-in Hybrid
- (b) Parallel Hybrid
- c) Natural Gas For Vehicles
- d) Series Hybrid

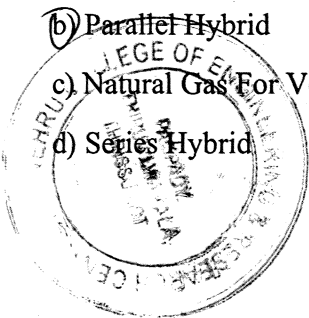



CERTIFICATION COURSE EXAM

CERTIFICATION COURSE NAME: Electric Vehicle (Future Mobility)

Time: 1 Hr

Marks: 30

Date: 8/10/16

Student Name: ARAVIND R PISHAROD

Reg. No.: NLA0000018

28/30

Department: Electrical And Electronics

1. A Electric vehicle equipped with push button start will enter the POWER ON mode, but will not enter the READY TO DRIVE mode. No diagnostic trouble codes (DTCs) are stored.

This could be caused by:

- (A) The high voltage safety plug is removed.
- (B) a failed brake on/off switch.
- (C) an empty fuel tank.
- (D) A 12 V battery which is disconnected



2. An electric vehicle equipped with a separate pump driven inverter cooling system has a diagnostic trouble code (DTC) for inverter overheating. The coolant is at the "full" level in the inverter coolant reservoir tank.

Technician A says that a failed inverter coolant pump could be the cause.

Technician B says that insufficient coolant in the internal combustion engine (ICE) cooling system could be the cause.

Who is right?

- (A) A only
- (B) B only
- (C) Both A and B
- (D) Neither A nor B



3. A Type-1 hybrid vehicle will enter READY TO DRIVE (KOER) mode but will not crank the internal combustion engine (ICE). When the vehicle is pushed in NEUTRAL gear range, the engine spins. Which of these could be the cause?

- (A) A depleted high voltage battery
- (B) A seized MG2
- (C) A failed crankshaft position sensor
- (D) A seized planetary gear set



4. During deceleration, the arrows on the power flow display appear as shown. This indicates:

- (A) the engine is running with energy flowing to the drive wheels.
- (B) the engine is running and driving the motor/generator to recharge the battery pack.
- (C) energy from the battery pack and the engine are blended and flowing to the drive wheels.
- (D) energy from the drive wheels is being used to recharge the battery pack.

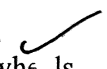

5. A Type-2 hybrid vehicle with a belt-type continuously variable transmission (CVT) bucks and jerks when accelerating from a stop.

Technician A says that using the wrong type of transmission fluid could be the cause.

Technician B says that a failing split pulley/steel belt could be the cause.

Who is right?

- A) A only (C) Both A and B
- (B) B only (D) Neither A nor B

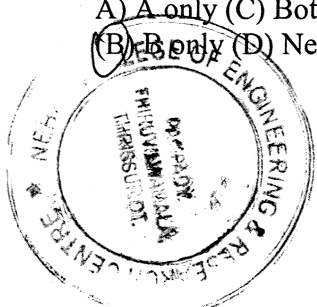

PRINCIPAL  
Neeru College of  
Engineering and Research Centre  
Pampady, Thiruvilwamala, Thrissur Dt  
Pin 680 597 Kerala

Reg.No.	Student Name	Marks/30
NCAOEEE040	Nikhil Babu	21
NCAOEEE041	Nithin K	22
NCAOEEE042	Pranav Ng	21
NCAOEEE043	Praveen N.m	24
NCAOEEE044	Preethi Ramadoss	24
NCAOEEE045	Rahul R	25
NCAOEEE046	Rosna S	26
NCAOEEE047	Sandeep Ks	21
NCAOEEE048	Sanjay Jayan	22
NCAOEEE049	Sarangi M V	25
NCAOEEE050	Sarath Janan.p	26
NCAOEEE051	Sarath Sathyan	25
NCAOEEE052	Satheesh M.b	24
NCAOEEE053	Sharang S Das	25
NCAOEEE054	Shyam Janan P	24
NCAOEEE055	Sidharth Krishnan	27
NCAOEEE056	Sivaprasad Sivadasan	26
NCAOEEE057	Saranju S.r	26
NCAOEEE059	Sunaina J	25
NCAOEEE060	Suraj J	25
NCAOEEE061	Tintu Mathew	26
NCAOEEE062	Vaisaghan P	25
NCAOEEE063	Vishnu K V	23
NCAOEEE064	Viswajith V	24
NCAOEEE065	Yadhukrishnan M S	24
NCAOEEE066	Ashiq Althaf	22
NCAOEEE067	Kishan K R	24
NCAOEEE068	Muhammed Raashid M V	25
NCAOEEE069	Minhaj Saifudheen	23

  
Course Coordinator

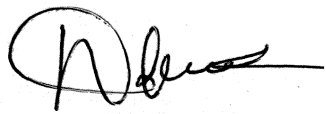
  
HoD

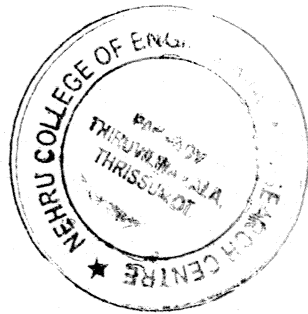

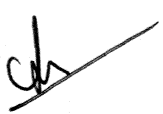
  
-A-  
PRINCIPAL  
Nehru College of  
Engineering and Research Centre  
Pampady Thiruvilwamala, Thirissur Dt  
Pin 680 597 Kerala

**NEHRU COLLEGE OF ENGINEERING & RESEARCH CENTRE**  
 (Accredited by NAAC)  
 Pampady, Thiruvilwamala, Thrissur Dt.  
**Performance Sheet for Certificate Course on "ELECTRIC VEHICLE(FUTURE MOBILITY) "**  
**Electrical & Electronics Engineering(UG) - (2014-18)Batch**  
**PERFORMANCE ANALYSIS**

Reg.No.	Student Name	Marks/30
NCAOEEE001	Aakash M R	26
NCAOEEE002	Abhishek K.m	25
NCAOEEE003	Adarsh C	26
NCAOEEE005	Aiswarya Venu	27
NCAOEEE006	Ajas Muhammed K P	24
NCAOEEE007	Ajay Krishnan	26
NCAOEEE008	Ajay P	22
NCAOEEE009	Ajeesh C.g	21
NCAOEEE010	Ajesh S	24
NCAOEEE011	Akash Deepak	26
NCAOEEE012	Alisha Davis	27
NCAOEEE014	Anand P Menon	22
NCAOEEE015	Aneesh L	21
NCAOEEE016	Aparna Unni U.k	24
NCAOEEE017	Aqib T K	23
NCAOEEE018	Aravind R Pisharody	28
NCAOEEE020	Arun K G	25
NCAOEEE021	Arun Prakash	25
NCAOEEE022	Arun Raj	24
NCAOEEE023	Athul Kp	26
NCAOEEE024	Chandni A Shaji	28
NCAOEEE026	Dhanya Babu	24
NCAOEEE027	DILU D	25
NCAOEEE028	Giriprasoon P.t	21
NCAOEEE029	Hariprasad S	21
NCAOEEE030	Jijitha Mol R	26
NCAOEEE031	Justin D James	25
NCAOEEE032	Jyothilakshmi V R	26
NCAOEEE033	Keerthi Up	27
NCAOEEE034	Kiran M.k	27
NCAOEEE036	Mariya Paul	28
NCAOEEE037	Mithun R	25
NCAOEEE038	Muhammed Salman Faris K	22
NCAOEEE039	Muhammed Sharooq Ali	<del>22</del>

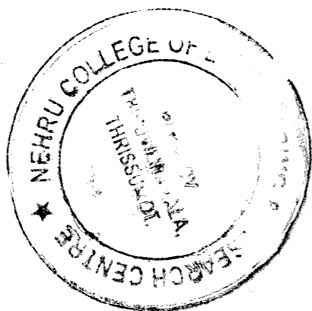

*(Signature)*  
**PRINCIPAL**  
 Nehru College of  
 Engineering and Research Centre  
 Pampady Thiruvilwamala, Thrissur Dt  
 Pin 680 597 Kerala



# NEHRU COLLEGE OF ENGINEERING AND RESEARCH CENTRE

(NAAC Accredited) (Approved by AICTE, Affiliated to Calicut University and A P J Abdul Kalam Technological University, Kerala)

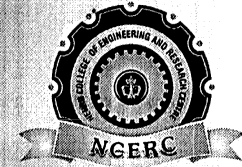

This is to Certify that Ms.PREETHI RAMADOSS of Electrical and Electronics Engineering Department has successfully completed the Certificate/Addon Course on EV(FUTURE MOBILITY)

from 23/07/2016 to 8/10/2016 at Nehru College of Engineering & Research Centre, Pamapdy.



Course Coordinator

HoD  
EEE Department

Principal  
NCERC



# NEHRU COLLEGE OF ENGINEERING AND RESEARCH CENTRE

(NAAC Accredited) (Approved by AICTE, Affiliated to Calicut University and A P J Abdul Kalam Technological University, Kerala)

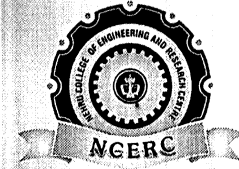

This is to Certify that Mr.JUSTIN D JAMES of Electrical and Electronics Engineering Department has successfully completed the Certificate/Addon Course on EV(FUTURE MOBILITY)

from 23/07/2016 to 8/10/2016 at Nehru College of Engineering & Research Centre, Pamapdy.

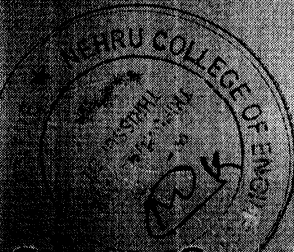

Course Coordinator

HoD  
EEE Department

PRINCIPAL  
Nehru College of Engineering and Research Centre  
Pamapdy, Thiruvananthapuram, Kerala

Principal  
NCERC



# NEHRU COLLEGE OF ENGINEERING AND RESEARCH CENTRE

(NAAC Accredited) (Approved by AICTE, Affiliated to Calicut University and A P J Abdul Kalam Technological University, Kerala)



This is to Certify that Ms. JIJITHA MOL R of Electrical and Electronics Engineering Department has successfully completed the Certificate/Addon Course on EV(FUTURE MOBILITY)

from 23/07/2016 to 8/10/2016 at Nehru College of Engineering & Research Centre, Pamapdy.

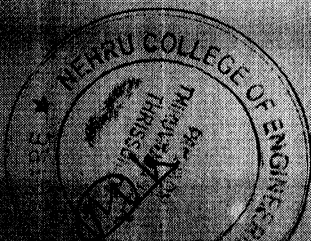

Course Coordinator

HoD  
EEE Department

PRINCIPAL  
Nehru College of  
Engineering and Research Centre  
Pamapdy, Thiruvilwamala, Thiruvananthapuram  
Pin - 680 597 Kerala

Principal  
NCERC



# NEHRU COLLEGE OF ENGINEERING AND RESEARCH CENTRE

(NAAC Accredited) (Approved by AICTE, Affiliated to Calicut University and A P J Abdul Kalam Technological University, Kerala)

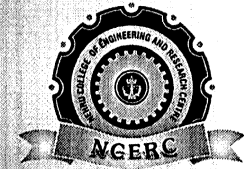

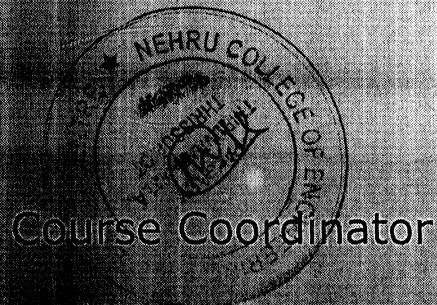

This is to Certify that Mr.AJAY KRISHNAN of Electrical and Electronics Engineering Department has successfully completed the Certificate/Addon Course on EV(FUTURE MOBILITY)

from 23/07/2016 to 8/10/2016 at Nehru College of Engineering & Research Centre, Pamapdy.



  
HoD  
EEE Department

  
PRINCIPAL  
Nehru College of  
Engineering and Research Centre  
Pamapdy, Thiruvilwamala, Thiruvananthapuram, Kerala  
Pin: 680 507  
  
Principal  
NCERC



# NEHRU COLLEGE OF ENGINEERING AND RESEARCH CENTRE

(NAAC Accredited) (Approved by AICTE, Affiliated to Calicut University and A P J Abdul Kalam Technological University, Kerala)

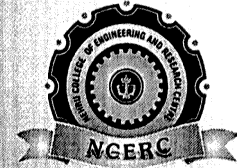

This is to Certify that Mr. ARUN PRAKASH of Electrical and Electronics Engineering Department has successfully completed the Certificate/Addon Course on EV(FUTURE MOBILITY)

from 23/07/2016 to 8/10/2016 at Nehru College of Engineering & Research Centre, Pamapdy.



Course Coordinator

HoD  
EEE Department

PRINCIPAL  
Nehru College of  
Engineering and Research Centre  
Pamapdy, Thiruvilwamala  
Pin: 686 50

Principal  
NCERC

**NEHRU COLLEGE OF ENGINEERING & RESEARCH CENTRE**  
(Accredited by NAAC)  
Pampady, Thiruvilwamala, Thrissur Dt.  
Certificate Course on " ELECTRIC VEHICLE (FUTURE MOBILITY) "  
Electrical & Electronics Engineering(UG) - (2015-19) Batch  
**ENROLLMENT LIST**

Reg.No.	Student Name
NCE15EE001	ABHIJIT KRISHNAN A
NCE15EE002	ABHIRAM C K
NCE15EE003	ABOO FARIS R
NCE15EE004	ADITHYA KRISHNA
NCE15EE005	AMBILI V
NCE15EE006	ANJALI A
NCE15EE007	ANJITH R NAIR
NCE15EE008	ARJUN A
NCE15EE009	ARJUN SASIKUMAR
NCE15EE010	ARJUN SURENDRAN
NCE15EE011	ARSHIFA A
NCE15EE012	ARUN V P
NCE15EE013	ARUN MOHAN V
NCE15EE014	ASWATHY A
NCE15EE015	ATHIRA S
NCE15EE016	ATHUL KAMAL R
NCE15EE017	BASIL P POULOSE
NCE15EE018	BINURAJ C
NCE15EE019	DAVIS VARGHESE
NCE15EE020	DEON MOHAMMED
NCE15EE021	DIYA R
NCE15EE022	GAYATHRI MURALIDHARAN
NCE15EE023	GREESHMA K
NCE15EE024	HARIKRISHNA P
NCE15EE025	HIMA M
NCE15EE026	HIMA M M
NCE15EE028	JAYAKRISHNAN K

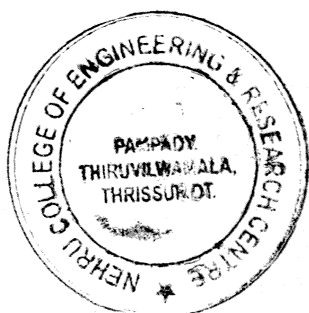

  
**PRINCIPAL**  
Nehru College of  
Engineering and Research Centre  
Pampady, Thiruvilwamala, Thrissur Dt  
Pin - 680 597 Kerala

**NEHRU COLLEGE OF ENGINEERING & RESEARCH CENTRE**  
(Accredited by NAAC)  
Pampady, Thiruvilwamala, Thrissur Dt.  
Certificate Course on " ELECTRIC VEHICLE (FUTURE MOBILITY) "  
Electrical & Electronics Engineering(UG) - (2015-19) Batch  
ENROLLMENT LIST

NCE15EE029	KARTHIK R REVI
NCE15EE030	KRIPA KRISHNA A
NCE15EE031	KRISHNADAS K
NCE15EE032	KRISHNAKUMAR P
NCE15EE033	LESLY CATHERINE
NCE15EE034	MIDUN S
NCE15EE035	MOHAMMED IBRAHIM N
NCE15EE036	NELSON P O
NCE15EE037	NIRMAL PRASAD K
NCE15EE038	PARAMESWARAN T K
NCE15EE039	PAVAN KRISHNAN K A
NCE15EE040	PRAJITHA K NAIR
NCE15EE041	PRANAV KUMAR S
NCE15EE043	RAJALAKSHMY S
NCE15EE044	RESHMA RAJ K
NCE15EE045	SAI KRISHNAN
NCE15EE046	SANDEEP T C
NCE15EE047	SANGEETHA V
NCE15EE048	SANJAY S
NCE15EE049	SHANILA P
NCE15EE050	SHAREEFA P A
NCE15EE051	SHILPA MANIKANDAN
NCE15EE052	SRUTHI RAMKUMAR
NCE15EE053	SUJITH V
NCE15EE054	SUSMITHA P
NCE15EE055	VISHNU V
NCE15EE056	VISHNU MENON P
LNCE15EE057	ARAVIND S SANKAR
LNCE15EE058	FAISAL P M
LNCE15EE060	JOMON GEORGE
LNCE15EE061	NIVED M JAYAN
LNCE15EE062	RONY C JOSH Y
LNCE15EE063	SREEJITH V S



Course Coordinator



HoD

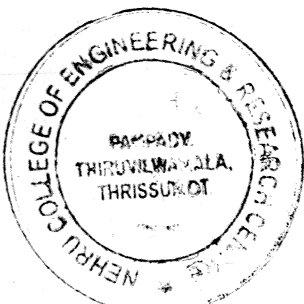

PRINCIPAL

Nehru College of  
Engineering and Research Centre  
Pampady Thiruvilwamala, Thrissur U  
Pin 680 597 Kerala

Register Number	Student Name	09-07-2016	23-07-2016	13-08-2016	27-08-2017	10-09-2017	24-09-2017
NCE15EE038	PARAMESWARAN T K	✓	✓	✓	✓	✓	✓
NCE15EE039	PAVAN KRISHNAN K A	✓	✓	✓	✓	✓	✓
NCE15EE040	PRAJITHA K NAIR	✓	✓	✓	✓	✓	✓
NCE15EE041	PRANAV KUMAR S	✓	✓	✓	✓	✓	✓
NCE15EE043	RAJALAKSHMY S	✓	✓	✓	✓	✓	✓
NCE15EE044	RESHMA RAJ K	✓	✓	✓	✓	✓	✓
NCE15EE045	SAI KRISHNAN	✓	✓	✓	✓	✓	✓
NCE15EE046	SANDEEP T C	✓	✓	✓	✓	✓	✓
NCE15EE047	SANGEETHA V	✓	✓	✓	✓	✓	✓
NCE15EE048	SANJAY S	✓	✓	✓	✓	✓	✓
NCE15EE049	SHANILA P	✓	✓	✓	✓	✓	✓
NCE15EE050	SHAREEFA P A	✓	✓	✓	✓	✓	✓
NCE15EE051	SHILPA MANIKANDAN	✓	✓	✓	✓	✓	✓
NCE15EE052	SRUTHI RAMKUMAR	✓	✓	✓	✓	✓	✓
NCE15EE053	SUJITH V	✓	✓	✓	✓	✓	✓
NCE15EE054	SUSMITHA P	✓	✓	✓	✓	✓	✓
NCE15EE055	VISHNU V	✓	✓	✓	✓	✓	✓
NCE15EE056	VISHNU MENON P	✓	✓	✓	✓	✓	✓
LNCE15EE057	ARAVIND S SANKAR	✓	✓	✓	✓	✓	✓
LNCE15EE058	FAISAL P M	✓	✓	✓	✓	✓	✓
LNCE15EE060	JOMON GEORGE	✓	✓	✓	✓	✓	✓
LNCE15EE061	NIVED M JAYAN	✓	✓	✓	✓	✓	✓
LNCE15EE062	RONY C JOSHY	✓	✓	✓	✓	✓	✓
LNCE15EE063	SREEJITH V S	✓	✓	✓	✓	✓	✓

*MB*

Course Coordinator

*[Signature]*

HoD

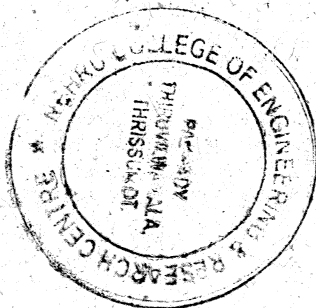

*[Signature]*

PRINCIPAL  
Nehru College of  
Engineering and Research Centre  
Thiruvithwamala Thiruvananthapuram  
Pin - 695 011 Kerala

Register Number	Student Name	09-07-2016		23-07-2016		13-08-2016		27-08-2017		10-09-2017		24-09-2017	
NCE15EE019	DAVIS VARGHESE	✓	✓	✓	✓	✓	✓	✓	✓	✓	✓	✓	✓
NCE15EE020	DEON MOHAMMED	✓	✓	✓	✓	✓	✓	✓	✓	✓	✓	✓	✓
NCE15EE021	DIYA R	✓	✓	✓	✓	✓	✓	✓	✓	✓	✓	✓	✓
NCE15EE022	GAYATHRI MURALIDHARAN	✓	✓	✓	✓	✓	✓	✓	✓	✓	✓	✓	✓
NCE15EE023	GREESHMA K	✓	✓	✓	✓	✓	✓	✓	✓	✓	✓	✓	✓
NCE15EE024	HARIKRISHNA P	✓	✓	✓	✓	✓	✓	✓	✓	✓	✓	✓	✓
NCE15EE025	HIMA M	✓	✓	✓	✓	✓	✓	✓	✓	✓	✓	✓	✓
NCE15EE026	HIMA M M	✓	✓	✓	✓	✓	✓	✓	✓	✓	✓	✓	✓
NCE15EE028	JAYAKRISHNAN K	✓	✓	✓	✓	✓	✓	✓	✓	✓	✓	✓	✓
NCE15EE029	KARTHIK R REVI	✓	✓	✓	✓	✓	✓	✓	✓	✓	✓	✓	✓
NCE15EE030	KRIPA KRISHNA A	✓	✓	✓	✓	✓	✓	✓	✓	✓	✓	✓	✓
NCE15EE031	KRISHNADAS K	✓	✓	✓	✓	✓	✓	✓	✓	✓	✓	✓	✓
NCE15EE032	KRISHNAKUMAR P	✓	✓	✓	✓	✓	✓	✓	✓	✓	✓	✓	✓
NCE15EE033	LESLEY CATHERINE	✓	✓	✓	✓	✓	✓	✓	✓	✓	✓	✓	✓
NCE15EE034	MIDUN S	✓	✓	✓	✓	✓	✓	✓	✓	✓	✓	✓	✓
NCE15EE035	MOHAMMED IBRAHIM N	✓	✓	✓	✓	✓	✓	✓	✓	✓	✓	✓	✓
NCE15EE036	NELSON P O	✓	✓	✓	✓	✓	✓	✓	✓	✓	✓	✓	✓
NCE15EE037	NIRMAL PRASAD K	✓	✓	✓	✓	✓	✓	✓	✓	✓	✓	✓	✓

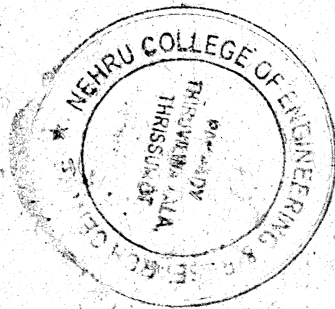

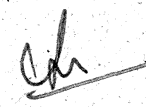
  
**PRINCIPAL**  
 Nehru College of  
 Engineering and Research Centre  
 Panipady Thiruvilwamala, Thirissur  
 Pin 680 597 Kerala

NEHRU COLLEGE OF ENGINEERING & RESEARCH CENTRE

(Accredited by NAAC)

Pampady, Thiruvilwamala, Thrissur Dt.

Attendance Sheet for Certificate Course on "ELECTRIC VEHICLE (FUTURE MOBILITY) "

Electrical & Electronics Engineering(UG) - (2015-19) Batch

Register Number	Student Name	09-07-2016		23-07-2016		13-08-2016		27-08-2017		10-09-2017		24-09-2017	
		FN	AN	FN	AN	FN	AN	FN	AN	FN	AN	FN	AN
NCE15EE001	ABHIJIT KRISHNAN A												
NCE15EE002	ABHIRAM C K	✓	✓	✓	✓	✓	✓	✓	✓	✓	✓	✓	✓
NCE15EE003	ABOO FARIS R	✓	✓	✓	✓	✓	✓	✓	✓	✓	✓	✓	✓
NCE15EE004	ADITHYA KRISHNA	✓	✓	✓	✓	✓	✓	✓	✓	✓	✓	✓	✓
NCE15EE005	AMBILI V	✓	✓	✓	✓	✓	✓	✓	✓	✓	✓	✓	✓
NCE15EE006	ANJALI A	✓	✓	✓	✓	✓	✓	✓	✓	✓	✓	✓	✓
NCE15EE007	ANJITH R NAIR	✓	✓	✓	✓	✓	✓	✓	✓	✓	✓	✓	✓
NCE15EE008	ARJUN A	✓	✓	✓	✓	✓	✓	✓	✓	✓	✓	✓	✓
NCE15EE009	ARJUN SASIKUMAR	✓	✓	✓	✓	✓	✓	✓	✓	✓	✓	✓	✓
NCE15EE010	ARJUN SURENDRAN	✓	✓	✓	✓	✓	✓	✓	✓	✓	✓	✓	✓
NCE15EE011	ARSHIFA A	✓	✓	✓	✓	✓	✓	✓	✓	✓	✓	✓	✓
NCE15EE012	ARUN V P	✓	✓	✓	✓	✓	✓	✓	✓	✓	✓	✓	✓
NCE15EE013	ARUN MOHAN V	A	A	A	A	A	A	A	A	A	A	A	A
NCE15EE014	ASWATHY A	✓	✓	✓	✓	✓	✓	✓	✓	✓	✓	✓	✓
NCE15EE015	ATHIRA S	✓	✓	✓	✓	✓	✓	✓	✓	✓	✓	✓	✓
NCE15EE016	ATHUL KAMAL R	✓	✓	✓	✓	✓	✓	✓	✓	✓	✓	✓	✓
NCE15EE017	BASIL P POULOSE	✓	✓	✓	✓	✓	✓	✓	✓	✓	✓	✓	✓
NCE15EE018	BINURAJ C	✓	✓	✓	✓	✓	✓	✓	✓	✓	✓	✓	✓

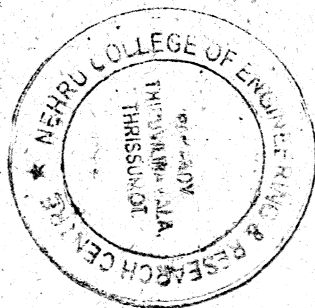

*[Signature]*  
**PRINCIPAL**  
 Nehru College of  
 Engineering and Research Centre  
 Pampady, Thiruvilwamala, Thrissur Dt.  
 Pin - 682 507 Kerala



c). biodiesel and electric power ✓

25. In a parallel hybrid:

- a). A gas engine runs an electric generator.
- b). A gas engine and electric motor can each turn the wheels.
- c). The engine has no connection to the transmissions

26. In a series hybrid:

- a). An electric motor acts as a backup to a gas engine.
- b). A gas engine and an electric motor alternately turn the wheels.
- c). A gas engine turns a generator, not the wheels. ✓

27. Small engines are more efficient than large engines because:

- a). They weigh less. ✓
- b). It takes less fuel to fill the cylinders.
- c). both A and B ✓

28. In a Prius, the power split device connects the:

- a). gasoline engine, generator and electric motor
- b). gasoline engine, electric motor and power train ✓
- c). gasoline engine, transmission and brakes

29. You should avoid abrupt stops in a hybrid car because:

- a). Hybrids are very sensitive to sudden changes in motion.
- b). The engine has more time to collect energy. ✓
- c). Repairs to regenerative braking systems are extremely expensive.

30. This is the of Hybrid Electric Vehicles

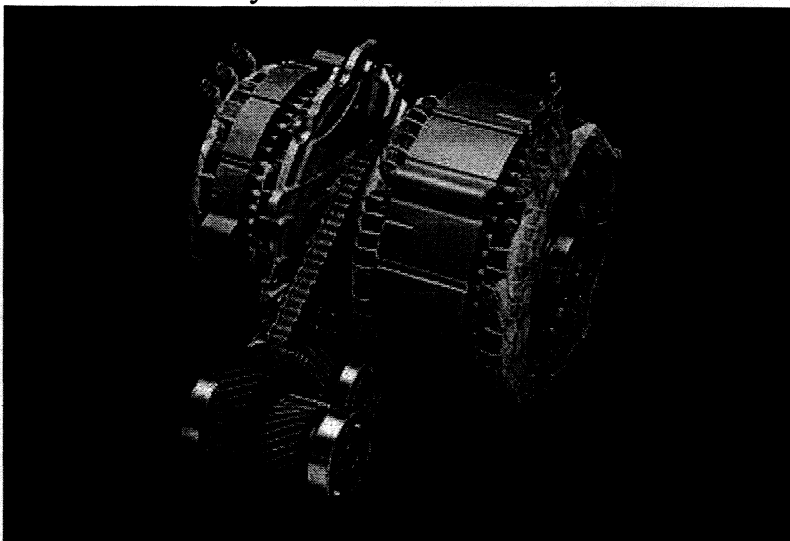

- a). Gearbox
- b). Motor Generator ✓
- c). Automatic Transmission
- d). Engine

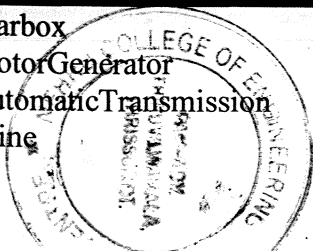



18. The benefits of a hybrid car include :

- a). reducing emissions
- b). improving gas mileage ✓
- c). high fuel consumption
- d). high speed driving

19. A \_\_\_\_\_ is a Hybrid source

- a). Mild Hybrid
- b). Full Hybrid
- c). Fuel Cell ✓
- d). Assist Hybrid

20. A Toyota Prius C Hybrid has \_\_\_\_\_ engine.

- a). 1
- b). 2 ✓
- c). half
- d). no

21. Select the cycle use in a Hybrid Engine.

- a). Otto
- b). Diesel
- c). Atkinson ✓
- d). Isentropic

22. Select the WRONG statement.

- a). Toyota produced the Insight Hybrid ✓
- b). Hybrid systems rely on very high voltages
- c). All of the high voltage cables are covered in orange sleeves for easy identification
- d). To test high voltage systems you need a Category 3 (CAT III) digital volt ohmmeter

23. Select the CORRECT statement about Integrated Motor Assist (IMA) hybrid system

- a). Produced by Honda ✓
- b). This system is the basis for many series parallel hybrid vehicles.
- c). This system is capable of instantaneously switching from one power source to another or combining the two.

24. The most common type of hybrid car combines the following:

- a). diesel and electric power
- b). gas and electric power

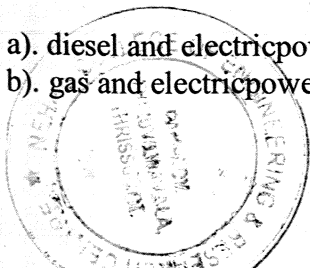



12. The Hybrid Electric Vehicle consists of:

- a) NGV engine + Gasoline engine
- b) IC engine + Gasoline engine ✓
- c) Electric motor + Electric motor
- d) IC engine + Electric motor

13. "In this system, the engine is used to supply electrical power to the motor, which then turns the wheels" Select the type of Hybrid System according to above description.

- a) Series Hybrid
- b) Parallel Hybrid ✓
- c) Plug-in Hybrid
- d) Series-parallel Hybrid

14. "The wheels are driven by both the engine and the motor" Select the type of Hybrid System according to above description.

- a) Series Hybrid
- b) Parallel Hybrid ✓
- c) Plug-in Hybrid
- d) Series-parallel Hybrid

15. Select the features of Hybrid Electric Vehicles

- a) Idle Stop
- b) EV Drive ✓
- c) Regenerative braking
- d) All the above.

16. The electric motor in a hybrid car can also act as:

- a) cooling fan
- b) fuel pump ✓
- c) generator
- d) None of the above

17. Regenerative braking involves:

- a) Nano fibers that repair the surface of brake pads
- b) reducing the amount of friction necessary to slow a car ✓
- c) reclaiming heat from the brakes and using it for power

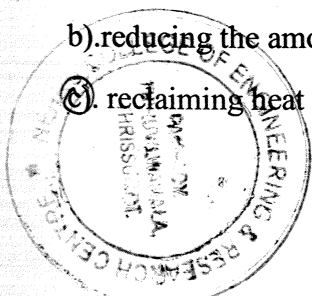



6. The MIL is illuminated and a "Battery Module Deterioration" diagnostic trouble code (DTC) is stored. The most likely cause is a failed:

- (A) high voltage battery.
- (B) high voltage inverter. X
- (C) motor/generator.
- (D) DC/DC converter.

7. What purpose does a generator serve in a hybrid vehicle?

- It converts nuclear energy into more nuclear energy.
- It converts mechanical energy into electrical energy. ✓
- It converts chemical energy into electrical energy.
- It converts electrical energy into mechanical energy.

8. What are the two main types of hybrid vehicle?

- The series hybrid vehicle and the mild hybrid vehicle. ✓
- The parallel hybrid vehicle and the full hybrid vehicle.
- The series hybrid vehicle and the parallel hybrid vehicle.
- The full hybrid vehicle and the empty hybrid vehicle.

9. Which sentence best describes a parallel hybrid vehicle?

- The engine is directly connected to the transmission. ✓
- The electric motor is directly connected to the transmission.
- Both of the above.
- None of the above.

10. Which of these is a purpose of the power-split device?

- To split electrical energy into mechanical energy. ✓
- To allow both the engine and electric motor to propel the vehicle.
- To recharge the battery while braking.
- To recharge the brakes while driving.

11. Which of the following is NOT the type of Hybrid Vehicle?

- a) Plug-in Hybrid
- b) Parallel Hybrid
- c) Natural Gas Fuel Vehicles

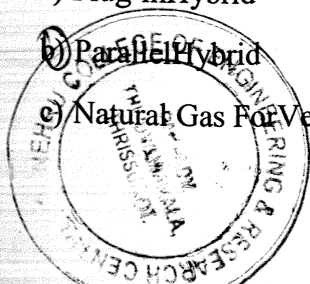



CERTIFICATION COURSE EXAM

CERTIFICATION COURSE NAME: Electric Vehicle (Future Mobility)

Time: 1Hr

Marks: 30

Date: 24/9/2017

Student Name: Arvind S Sankar

Reg. No.: LNCE15EE057

28/30

Department: Electrical And Electronics

1. A Electric vehicle equipped with push button start will enter the POWER ON mode, but will not enter the READY TO DRIVE mode. No diagnostic trouble codes (DTCs) are stored.

This could be caused by:

- (A) The high voltage safety plug is removed.
- (B) a failed brake on/off switch.
- (C) an empty fuel tank.
- (D) A 12 V battery which is disconnected

2. An electric vehicle equipped with a separate pump driven inverter cooling system has a diagnostic trouble code (DTC) for inverter overheating. The coolant is at the "full" level in the inverter coolant reservoir tank.

Technician A says that a failed inverter coolant pump could be the cause.

Technician B says that insufficient coolant in the internal combustion engine (ICE) cooling system could be the cause.

Who is right?

- (A) A only
- (B) B only
- (C) Both A and B
- (D) Neither A nor B

3. A Type-1 hybrid vehicle will enter READY TO DRIVE (KOER) mode but will not crank the internal combustion engine (ICE). When the vehicle is pushed in NEUTRAL gear range, the engine spins. Which of these could be the cause?

- (A) A depleted high voltage battery
- (B) A seized MG2
- (C) A failed crankshaft position sensor
- (D) A seized planetary gear set

4. During deceleration, the arrows on the power flow display appear as shown. This indicates:

- (A) the engine is running with energy flowing to the drivewheels.
- (B) the engine is running and driving the motor/generator to recharge the battery pack.
- (C) energy from the battery pack and the engine are blended and flowing to the drivewheels.
- (D) energy from the drive wheels is being used to recharge the battery pack.

5. A Type-2 hybrid vehicle with a belt-type continuously variable transmission (CVT) bucks and jerks when accelerating from a stop.

Technician A says that using the wrong type of transmission fluid could be the cause.

Technician B says that a failing split pulley/steel belt could be the cause.

Who is right?

- A) A only (C) Both A and B
- (B) B only (D) Neither A nor B

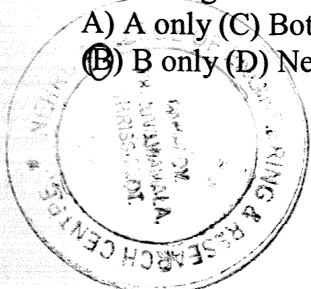

Principal's signature

PRINCIPAL  
Nehru College of  
Engineering and Research Centre  
Pampady, Thiruvilwamala, Thrissur Dt  
Pin - 680 597 Kerala



©. biodiesel and electricpower ✓

25. In a parallelhybrid:

- a). A gas engine runs an electricgenerator.
- b). A gas engine and electric motor can each turn the wheels.**
- c). The engine has no connection to thetransmissions ✓

26. In a seriesybrid:

- a). An electric motor acts as a backup to a gasengine.**
- b). A gas engine and an electric motor alternately turn the wheels. ✓
- c). A gas engine turns a generator, not thewheels.

27. Small engines are more efficient than large engines because:

- a). They weighless.**
- b). It takes less fuel to fill the cylinders. ✓
- c). both A and B

28. In a Prius, the power split device connectsthe:

- a). gasoline engine, generator and electric motor
- b). gasoline engine, electric motor and power train ✓
- c). gasoline engine, transmission and brakes**

29. You should avoid abrupt stops in a hybrid carbecause:

- a). Hybrids are very sensitive to sudden changes in motion.
- b). The engine has more time to collect energy.
- c). Repairs to regenerative braking systems are extremely expensive.** ✓

30. This is the of Hybrid ElectricVehicles

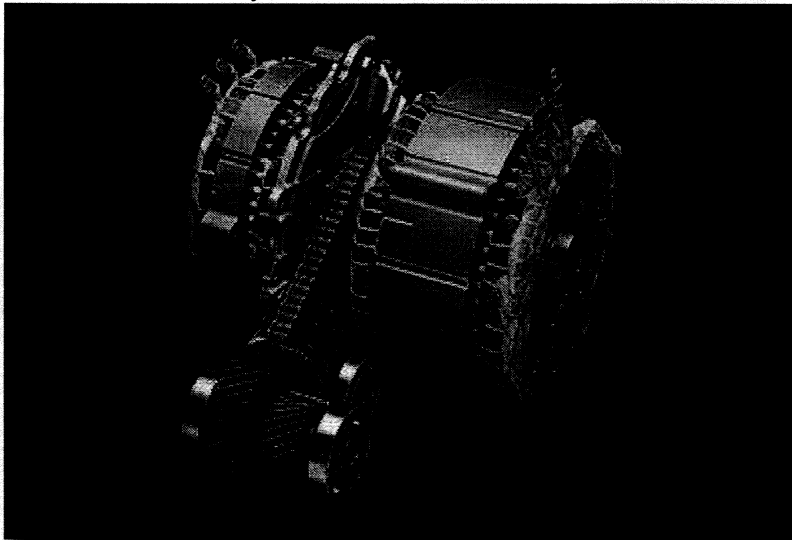

- a). Gearbox
- b). MotorGenerator**
- c). AutomaticTransmission
- d). Engine

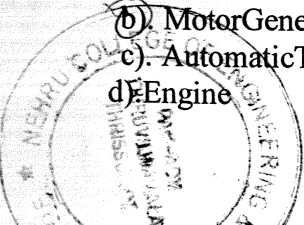



18. The benefits of a hybrid car include :

- a) reducing emissions ✓
- b) improving gas mileage
- c) high fuel consumption
- d) high speed driving

19. A \_\_\_\_\_ is a Hybrid source

- a) Mild Hybrid
- b) Full Hybrid
- c) Fuel Cell ✓
- d) Assist Hybrid

20. A Toyota Prius C Hybrid has \_\_\_\_\_ engine.

- a) 1
- b) 2
- c) half ✓
- d) no

21. Select the cycle use in a Hybrid Engine.

- a) Otto
- b) Diesel
- c) Atkinson ✓
- d) Isentropic

22. Select the WRONG statement.

- a) Toyota produced the Insight Hybrid
- b) Hybrid systems rely on very high voltages
- c) All of the high voltage cables are covered in orange sleeves for easy identification ✓
- d) To test high voltage systems you need a Category 3 (CAT III) digital volt ohmmeter

23. Select the CORRECT statement about Integrated Motor Assist (IMA) hybrid system

- a) Produced by Honda ✓
- b) This system is the basis for many series parallel hybrid vehicles.
- c) This system is capable of instantaneously switching from one power source to another or combining the two.

24. The most common type of hybrid car combines the following:

- a) diesel and electric power
- b) gas and electric power

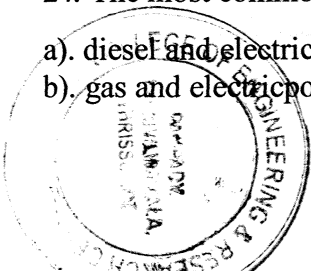



12. The Hybrid Electric Vehicle consists of:

- a) NGV engine + Gasoline engine
- b) IC engine + Gasoline engine
- c) Electric motor + Electric motor
- d) IC engine + Electric motor

13. "In this system, the engine is used to supply electrical power to the motor, which then turns the wheels" Select the type of Hybrid System according to above description.

- a). Series Hybrid
- b). Parallel Hybrid
- c). Plug-in Hybrid
- d). Series-parallel Hybrid

14. "The wheels are driven by both the engine and the motor" Select the type of Hybrid System according to above description.

- a). Series Hybrid
- b). Parallel Hybrid
- c). Plug-in Hybrid
- d). Series-parallel Hybrid

15. Select the features of Hybrid Electric Vehicles

- a). Idle Stop
- b). EV Drive
- c). Regenerative braking
- d). All the above.

16. The electric motor in a hybrid car can also act as:

- a). cooling fan
- b). fuel pump
- c). generator
- d). None of the above

17. Regenerative braking involves:

- a). Nano fibers that repair the surface of brake pads
- b). reducing the amount of friction necessary to slow a car
- c). reclaiming heat from the brakes and using it for power

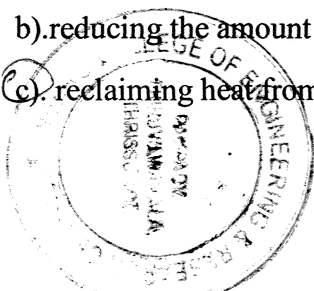



6. The MIL is illuminated and a "Battery Module Deterioration" diagnostic trouble code (DTC) is stored. The most likely cause is a failed:

- (A) high voltage battery.
- (B) high voltage inverter.
- (C) motor/generator.
- (D) DC/DC converter.

7. What purpose does a generator serve in a hybrid vehicle?

- It converts nuclear energy into more nuclear energy.
- It converts mechanical energy into electrical energy.
- It converts chemical energy into electrical energy.
- It converts electrical energy into mechanical energy.

8. What are the two main types of hybrid vehicle?

- The series hybrid vehicle and the mild hybrid vehicle.
- The parallel hybrid vehicle and the full hybrid vehicle.
- The series hybrid vehicle and the parallel hybrid vehicle.
- The full hybrid vehicle and the empty hybrid vehicle.

9. Which sentence best describes a parallel hybrid vehicle?

- The engine is directly connected to the transmission.
- The electric motor is directly connected to the transmission.
- Both of the above.
- None of the above.

10. Which of these is a purpose of the power-split device?

- To split electrical energy into mechanical energy.
- To allow both the engine and electric motor to propel the vehicle.
- To recharge the battery while braking.
- To recharge the brakes while driving.

11. Which of the following is NOT the type of Hybrid Vehicle?

- a) Plug-in Hybrid
- b) Parallel Hybrid
- c) Natural Gas For Vehicles

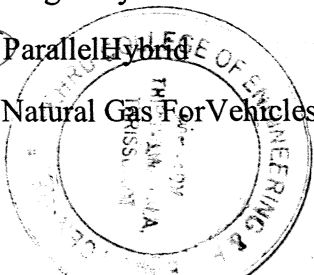



**NEHRU COLLEGE OF ENGINEERING AND RESEARCH CENTRE**  
(NAAC Accredited)

(Approved by AICTE, Affiliated to APJ Abdul Kalam Technological University, Kerala)



Ansops 21

**CERTIFICATION COURSE EXAM**

**CERTIFICATION COURSE NAME: Electric Vehicle (Future Mobility)**

**Time: 1Hr**

**Marks: 30**

**Date: 24-09-2017**

**Student Name: A308 FARIS.R**

**Reg. No.: NCEISEE-003**

27  
30

**Department: Electrical And Electronics**

1. A Electric vehicle equipped with push button start will enter the POWER ON mode, but will not enter the READY TO DRIVE mode. No diagnostic trouble codes (DTCs) are stored. This could be caused by:

- (A) The high voltage safety plug is removed.
- (B) a failed brake on/off switch.
- (C) an empty fuel tank.
- (D) A 12 V battery which is disconnected

2. An electric vehicle equipped with a separate pump driven inverter cooling system has a diagnostic trouble code (DTC) for inverter overheating. The coolant is at the "full" level in the inverter coolant reservoir tank.

Technician A says that a failed inverter coolant pump could be the cause.

Technician B says that insufficient coolant in the internal combustion engine (ICE) cooling system could be the cause.

Who is right?

- (A) A only
- (B) B only
- (C) Both A and B
- (D) Neither A nor B

3. A Type-1 hybrid vehicle will enter READY TO DRIVE (KOER) mode but will not crank the internal combustion engine (ICE). When the vehicle is pushed in NEUTRAL gear range, the engine spins. Which of these could be the cause?

- (A) A depleted high voltage battery
- (B) A seized MG2
- (C) A failed crankshaft position sensor
- (D) A seized planetary gearset

4. During deceleration, the arrows on the power flow display appear as shown. This indicates:

- (A) the engine is running with energy flowing to the drivewheels.
- (B) the engine is running and driving the motor/generator to recharge the battery pack.
- (C) energy from the battery pack and the engine are blended and flowing to the drivewheels.
- (D) energy from the drive wheels is being used to recharge the battery pack.

5. A Type-2 hybrid vehicle with a belt-type continuously variable transmission (CVT) bucks and jerks when accelerating from a stop.

Technician A says that using the wrong type of transmission fluid could be the cause.

Technician B says that a failing split pulley/steel belt could be the cause.

Who is right?

- (A) A only
- (C) Both A and B
- (B) B only
- (D) Neither A nor B

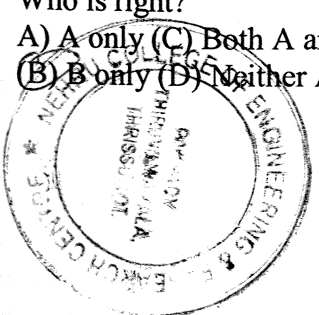

*[Signature]*

**PRINCIPAL**  
Nehru College of  
Engineering and Research Centre  
Pampady, Thiruvilwamala, Thrissur Dt  
Pin 680 597 Kerala



D. biodiesel and electric power ✓

25. In a parallel hybrid:

- a). A gas engine runs an electric generator.
- b). A gas engine and electric motor can each turn the wheels. ✓
- c). The engine has no connection to the transmissions

26. In a series hybrid:

- a). An electric motor acts as a backup to a gas engine. ✓
- b). A gas engine and an electric motor alternately turn the wheels.
- c). A gas engine turns a generator, not the wheels.

27. Small engines are more efficient than large engines because:

- a). They weigh less. ✓
- b). It takes less fuel to fill the cylinders.
- c). both A and B

28. In a Prius, the power split device connects the:

- a). gasoline engine, generator and electric motor
- b). gasoline engine, electric motor and power train ✓
- c). gasoline engine, transmission and brakes

29. You should avoid abrupt stops in a hybrid car because:

- a). Hybrids are very sensitive to sudden changes in motion.
- b). The engine has more time to collect energy.
- c). Repairs to regenerative braking systems are extremely expensive. ✓

30. This is the of Hybrid Electric Vehicles

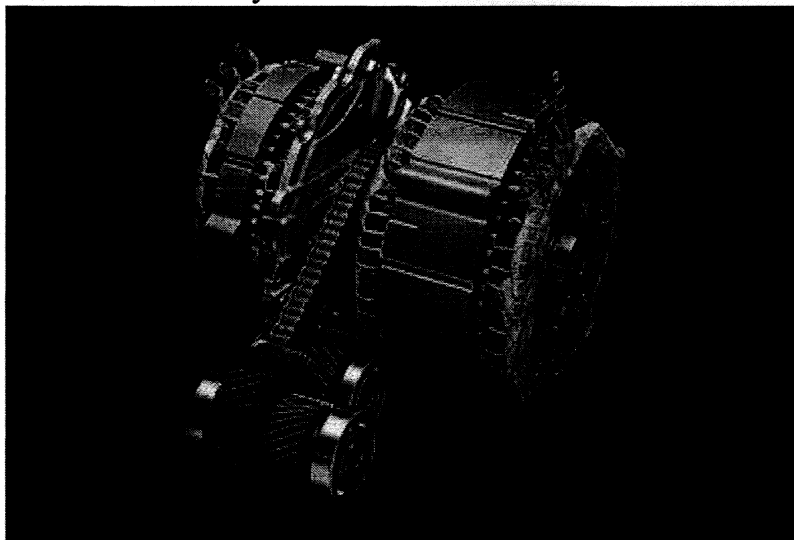

- a). Gearbox
- b). Motor Generator
- c). Automatic Transmission
- d). Engine

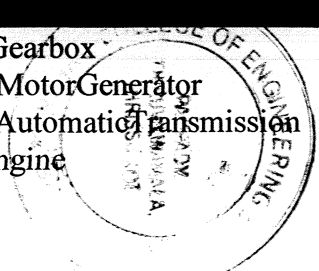

PRINCIPAL  
Nehru College of  
Engineering and Research Centre  
Panampady Thiruvilwamala, Thrissur Dist  
Pin - 680 507 Kerala



18. The benefits of a hybrid car include :

- a). reducing emissions
- b). improving gas mileage ✓
- c). high fuel consumption
- d). high speed driving

19. A \_\_\_\_\_ is a Hybrid source

- a). Mild Hybrid
- b). Full Hybrid
- c). Fuel Cell ✓
- d). Assist Hybrid

20. A Toyota Prius C Hybrid has \_\_\_\_\_ engine.

- a). 1
- b). 2 ✓
- c). half
- d). no

21. Select the cycle use in a Hybrid Engine.

- a). Otto
- b). Diesel
- c). Atkinson ✓
- d). Isentropic

22. Select the WRONG statement.

- a). Toyota produced the Insight Hybrid ✓
- b). Hybrid systems rely on very high voltages
- c). All of the high voltage cables are covered in orange sleeves for easy identification
- d). To test high voltage systems you need a Category 3 (CAT III) digital voltohmmeter

23. Select the CORRECT statement about Integrated Motor Assist (IMA) hybrid system

- a). Produced by Honda ✓
- b). This system is the basis for many series parallel hybrid vehicles.
- c). This system is capable of instantaneously switching from one power source to another or combining the two.

24. The most common type of hybrid car combines the following:

- a). diesel and electric power
- b). gas and electric power

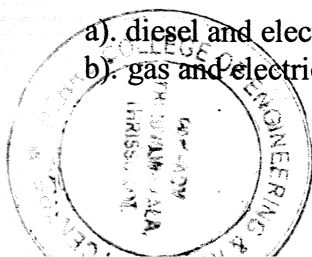



12. The Hybrid Electric Vehicle consists of:

- a) NGV engine + Gasoline engine
- b) IC engine + Gasoline engine
- c) Electric motor + Electric motor
- d) IC engine + Electric motor

13. "In this system, the engine is used to supply electrical power to the motor, which then turns the wheels" Select the type of Hybrid System according to above description.

- a) Series Hybrid
- b) Parallel Hybrid
- c) Plug-in Hybrid
- d) Series-parallel Hybrid

14. "The wheels are driven by both the engine and the motor" Select the type of Hybrid System according to above description.

- a) Series Hybrid
- b) Parallel Hybrid
- c) Plug-in Hybrid
- d) Series-parallel Hybrid

15. Select the features of Hybrid Electric Vehicles

- a) Idle Stop
- b) EV Drive
- c) Regenerative braking
- d) All the above.

16. The electric motor in a hybrid car can also act as:

- a) cooling fan
- b) fuel pump
- c) generator
- d) None of the above

17. Regenerative braking involves:

- a) Nano fibers that repair the surface of brake pads
- b) reducing the amount of friction necessary to slow a car
- c) reclaiming heat from the brakes and using it for power

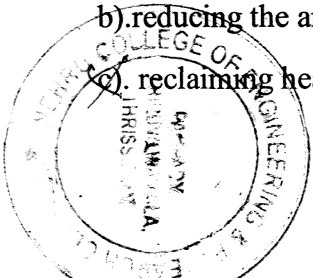



**NEHRU COLLEGE OF ENGINEERING AND RESEARCH CENTRE  
(NAAC Accredited)**

(Approved by AICTE, Affiliated to APJ Abdul Kalam Technological University, Kerala)



d) SeriesHybrid



6. The MIL is illuminated and a "Battery Module Deterioration" diagnostic trouble code (DTC) is stored. The most likely cause is a failed:

- (A) high voltage battery.
- (B) high voltage inverter.
- (C) motor/generator.
- (D) DC/DC converter.

7. What purpose does a generator serve in a hybrid vehicle?

- It converts nuclear energy into more nuclear energy.
- It converts mechanical energy into electrical energy. ✓
- It converts chemical energy into electrical energy.
- It converts electrical energy into mechanical energy.

8. What are the two main types of hybrid vehicle?

- The series hybrid vehicle and the mild hybrid vehicle. ✓
- The parallel hybrid vehicle and the full hybrid vehicle.
- The series hybrid vehicle and the parallel hybrid vehicle.
- The full hybrid vehicle and the empty hybrid vehicle.

9. Which sentence best describes a parallel hybrid vehicle?

- The engine is directly connected to the transmission.
- The electric motor is directly connected to the transmission. ✓
- Both of the above.
- None of the above.

10. Which of these is a purpose of the power-split device?

- To split electrical energy into mechanical energy.
- To allow both the engine and electric motor to propel the vehicle. ✓
- To recharge the battery while braking.
- To recharge the brakes while driving.

11. which of the following is NOT the type of Hybrid Vehicle?

- a) Plug-in Hybrid
- b) Parallel Hybrid ✓
- c) Natural Gas For Vehicles

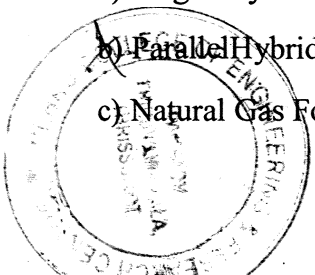



NEHRU COLLEGE OF ENGINEERING AND RESEARCH CENTRE  
(NAAC Accredited)

(Approved by AICTE, Affiliated to APJ Abdul Kalam Technological University, Kerala)



CERTIFICATION COURSE EXAM

CERTIFICATION COURSE NAME: Electric Vehicle (Future Mobility)

Time: 1 Hr

Marks: 30

Date: 24/9/17

Student Name: Aswathy - A

Reg. No.: NCEISEED14

28/30

Department: Electrical And Electronics

1. An electric vehicle equipped with push button start will enter the POWER ON mode, but will not enter the READY TO DRIVE mode. No diagnostic trouble codes (DTCs) are stored.

This could be caused by:

- (A) The high voltage safety plug is removed.
- (B) a failed brake on/off switch.
- (C) an empty fuel tank.
- (D) A 12 V battery which is disconnected

2. An electric vehicle equipped with a separate pump driven inverter cooling system has a diagnostic trouble code (DTC) for inverter overheating. The coolant is at the "full" level in the inverter coolant reservoir tank.

Technician A says that a failed inverter coolant pump could be the cause.

Technician B says that insufficient coolant in the internal combustion engine (ICE) cooling system could be the cause.

Who is right?

- (A) A only
- (B) B only
- (C) Both A and B
- (D) Neither A nor B

3. A Type-1 hybrid vehicle will enter READY TO DRIVE (KOER) mode but will not crank the internal combustion engine (ICE). When the vehicle is pushed in NEUTRAL gear range, the engine spins. Which of these could be the cause?

- (A) A depleted high voltage battery
- (B) A seized MG2
- (C) A failed crankshaft position sensor
- (D) A seized planetary gearset

4. During deceleration, the arrows on the power flow display appear as shown. This indicates:

- (A) the engine is running with energy flowing to the drivewheels.
- (B) the engine is running and driving the motor/generator to recharge the battery pack.
- (C) energy from the battery pack and the engine are blended and flowing to the drivewheels.
- (D) energy from the drive wheels is being used to recharge the battery pack.

5. A Type-2 hybrid vehicle with a belt-type continuously variable transmission (CVT) bucks and jerks when accelerating from a stop.

Technician A says that using the wrong type of transmission fluid could be the cause.

Technician B says that a failing split pulley/steel belt could be the cause.

Who is right?

- (A) A only (C) Both A and B
- (B) B only (D) Neither A nor B

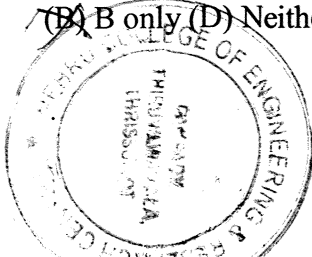

  
PRINCIPAL  
Nehru College of  
Engineering and Research Centre  
Pampady Thiruvilwamata, Thiruvananthapuram Dt  
Pin 680 597 Kerala

Reg.No.	Student Name	Marks/30
NCE15EE029	KARTHIK R REVI	26
NCE15EE030	KRIPA KRISHNA A	27
NCE15EE031	KRISHNADAS K	26
NCE15EE032	KRISHNAKUMAR P	25
NCE15EE033	LESLY CATHERINE	28
NCE15EE034	MIDUN S	26
NCE15EE035	MOHAMMED IBRAHIM N	25
NCE15EE036	NELSON P O	26
NCE15EE037	NIRMAL PRASAD K	24
NCE15EE038	PARAMESWARAN T K	26
NCE15EE039	PAVAN KRISHNAN K A	26
NCE15EE040	PRAJITHA K NAIR	27
NCE15EE041	PRANAV KUMAR S	24
NCE15EE043	RAJALAKSHMY S	27
NCE15EE044	RESHMA RAJ K	23
NCE15EE045	SAI KRISHNAN	22
NCE15EE046	SANDEEP T C	22
NCE15EE047	SANGEETHA V	24
NCE15EE048	SANJAY S	24
NCE15EE049	SHANILA P	26
NCE15EE050	SHAREEFA P A	28
NCE15EE051	SHILPA MANIKANDAN	29
NCE15EE052	SRUTHI RAMKUMAR	26
NCE15EE053	SUJITH V	25
NCE15EE054	SUSMITHA P	26
NCE15EE055	VISHNU V	27
NCE15EE056	VISHNU MENON P	27
LNCE15EE057	ARAVIND S SANKAR	28
LNCE15EE058	FAISAL P M	25
LNCE15EE060	JOMON GEORGE	25
LNCE15EE061	NIVED M JAYAN	26
LNCE15EE062	RONY C JOSHY	24
LNCE15EE063	SREEJITH V S	28



Course Coordinator



HoD

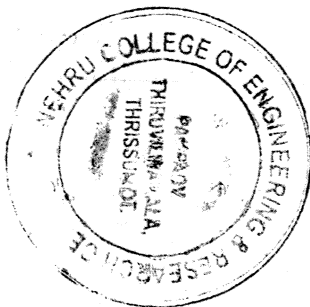

PRINCIPAL

Nehru College of  
Engineering and Research Centre  
Panpady Thiruvilwamala, Thrissur Dt  
Pin - 680 597 Kerala

NEHRU COLLEGE OF ENGINEERING & RESEARCH CENTRE

(Accredited by NAAC)

Pampady, Thiruvilwamala, Thrissur Dt.

Performance Sheet for Certificate Course on "ELECTRIC VEHICLE (FUTURE MOBILITY) "  
Electrical & Electronics Engineering(UG) - (2015-19) Batch  
PERFORMANCE ANALYSIS

Reg.No.	Student Name	Marks/30
NCE15EE001	ABHIJIT KRISHNAN A	24
NCE15EE002	ABHIRAM C K	25
NCE15EE003	ABOO FARIS R	27
NCE15EE004	ADITHYA KRISHNA	27
NCE15EE005	AMBILI V	28
NCE15EE006	ANJALI A	25
NCE15EE007	ANJITH R NAIR	22
NCE15EE008	ARJUN A	23
NCE15EE009	ARJUN SASIKUMAR	22
NCE15EE010	ARJUN SURENDRAN	24
NCE15EE011	ARSHIFA A	26
NCE15EE012	ARUN V P	21
NCE15EE013	ARUN MOHAN V	-A-
NCE15EE014	ASWATHY A	28
NCE15EE015	ATHIRA S	27
NCE15EE016	ATHUL KAMAL R	20
NCE15EE017	BASIL P POULOSE	24
NCE15EE018	BINURAJ C	25
NCE15EE019	DAVIS VARGHESE	21
NCE15EE020	DEON MOHAMMED	23
NCE15EE021	DIYA R	25
NCE15EE022	GAYATHRI MURALIDHARAN	25
NCE15EE023	GREESHMA K	26
NCE15EE024	HARIKRISHNA P	24
NCE15EE025	HIMA M	24
NCE15EE026	HIMA M M	26
NCE15EE028	JAYAKRISHNAN K	22

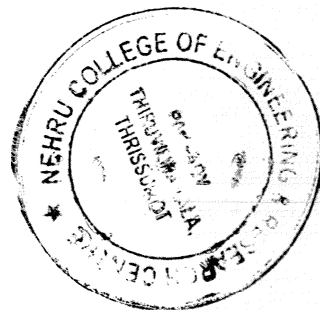

*cb*  
PRINCIPAL  
Nehru College of  
Engineering and Research Centre  
Pampady Thiruvilwamala, Thrissur Dt  
Pin 686 507 Kerala



# NEHRU COLLEGE OF ENGINEERING AND RESEARCH CENTRE

(NAAC Accredited) (Approved by AICTE, Affiliated to Calicut University and A P J Abdul Kalam Technological University, Kerala)

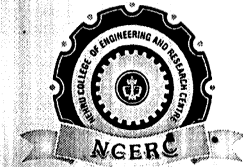

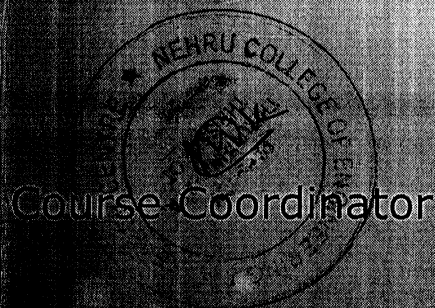

This is to Certify that Ms.LESLY CATHERINE of Electrical and Electronics Engineering Department has successfully completed the Certificate/Addon Course on EV(FUTURE MOBILITY)

from 23/07/2016 to 8/10/2016 at Nehru College of Engineering & Research Centre, Pamapdy.



Course Coordinator

  
HOD  
EEE Department

  
PRINCIPAL  
Nehru College of  
Engineering and Research Centre  
Pamapdy, Thiruvilvamkhal, Kerala

  
Principal  
NCERC



# NEHRU COLLEGE OF ENGINEERING AND RESEARCH CENTRE

(NAAC Accredited) (Approved by AICTE, Affiliated to Calicut University and A P J Abdul Kalam Technological University, Kerala)

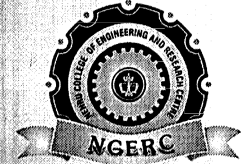



This is to Certify that Mr. KRISHNA DAS K of Electrical and Electronics Engineering Department has successfully completed the Certificate/Addon Course on EV(FUTURE MOBILITY)

from 23/07/2016 to 8/10/2016 at Nehru College of Engineering & Research Centre, Pamapdy.

  
Course Coordinator

  
HoD  
EEE Department

  
PRINCIPAL  
Nehru College of  
Engineering and Research Centre  
Pampady, Thiruvilwamala, Thrissur Dt  
Pin - 680 597, Kerala

  
Principal  
NCERC



# NEHRU COLLEGE OF ENGINEERING AND RESEARCH CENTRE

(NAAC Accredited) (Approved by AICTE, Affiliated to Calicut University and A P J Abdul Kalam Technological University, Kerala)

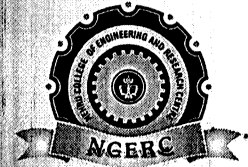

This is to Certify that Ms. DIYA R of Electrical and Electronics Engineering Department has successfully completed the Certificate/Addon Course on EV(FUTURE MOBILITY)

from 23/07/2016 to 8/10/2016 at Nehru College of Engineering & Research Centre, Pamapdy.

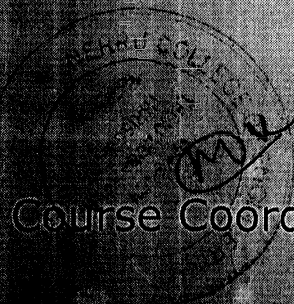

Course Coordinator

HoD  
EEE Department

PRINCIPAL  
Nehru College of  
Engineering and Research Centre  
Pamapdy, Thiruvilwamala, Thiruvananthapuram  
Ph: 630 597, Kerala

Principal  
NCERC



# NEHRU COLLEGE OF ENGINEERING AND RESEARCH CENTRE

(NAAC Accredited) (Approved by AICTE, Affiliated to Calicut University and A P J Abdul Kalam Technological University, Kerala)

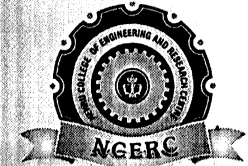

This is to Certify that Ms.ATHIRA S of Electrical and Electronics Engineering Department has successfully completed the Certificate/Addon Course on EV(FUTURE MOBILITY)

from 23/07/2016 to 8/10/2016 at Nehru College of Engineering & Research Centre, Pamapdy.

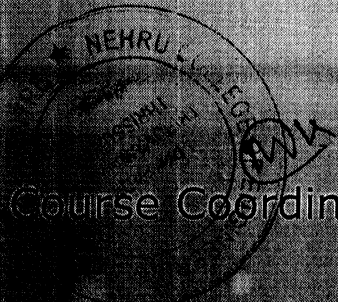

Course Coordinator

HoD  
EEE Department

PRINCIPAL  
Nehru College of  
Engineering and Research Centre  
Pamapdy, Thrissur

Principal  
NCERC



# NEHRU COLLEGE OF ENGINEERING AND RESEARCH CENTRE

(NAAC Accredited) (Approved by AICTE, Affiliated to Calicut University and A P J Abdul Kalam Technological University, Kerala)

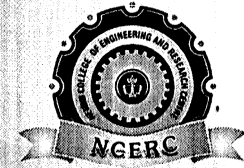



This is to Certify that Mr.ARJUN SURENDRAN of Electrical and Electronics Engineering Department has successfully completed the Certificate/Addon Course on EV(FUTURE MOBILITY)

from 23/07/2016 to 8/10/2016 at Nehru College of Engineering & Research Centre, Pamapdy.

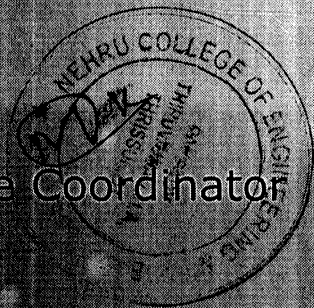
Course Coordinator

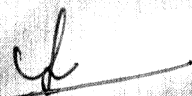

  
HoD  
EEE Department

  
PRINCIPAL  
Nehru College of  
Engineering and Research Centre  
Pamapdy, Thiruvilwamala, Thrissur  
Pin - 686 597 Kerala  
  
Principal  
NCERC

# NEHRU COLLEGE OF ENGINEERING AND RESEARCH CENTRE





(ACCREDITED BY NAAC)

PAMPADY, THIRUVILWAMALA, THRISSUR DIST.

## MINUTES OF DEPARTMENT ADVISORY COMMITTEE MEETING HELD ON 11/07/2016

A meeting of the Department Advisory Committee (DAC) was held on 11<sup>th</sup> July 2016 at 1:00 PM in the chamber of HoD, EEE department.

The following members were present:

1. Prof. D.K Narayanan-HoD, EEE Dept. 
2. Mr. Rajesh P-Assistant Professor, EEE Dept. 
3. Mr. David E-Assistant Professor, EEE Dept. 
4. Mr. Maheswaran K-Assistant Professor, EEE Dept. 
5. Mr. Rajkumar G-Assistant Professor, EEE Dept. 

The following decisions were taken:

1. It was decided to conduct a certificate course on "ELECTRIC VEHICLE (FUTURE MOBILITY)" during the second and fourth Saturdays of the academic year 2016-17 for a period of 30 hours.
2. The course will update the technical knowledge of students in the latest developments related to the field of Electric Vehicle (EV) technology.
3. It was decided to provide the course for 2014-18 and 2015-19 batch UG students.
4. Also, it was decided to conduct a certificate course on "EV POWER TRAIN" during the second and fourth Saturdays of the academic year 2016-17 for a period of 30 hours.
5. The course will update the technical knowledge of students in the latest developments related to the field of Electric Vehicle (EV) technology and on power trains, its operation, costs etc.
6. It was decided to provide the course for 2013-17 batch UG students.
7. Also, it was decided to ensure compulsory attendance and staff advisors should monitor the same.

The meeting came to an end at 1:45 PM.

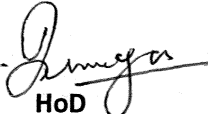
  
HoD

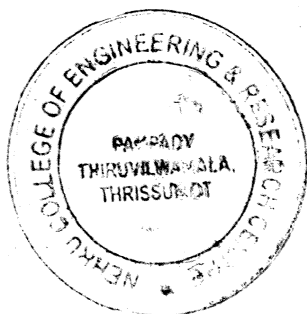

  
PRINCIPAL  
Nehru College of  
Engineering and Research Centre  
Pampady, Thiruvilwamala, Thrissur Dt  
Pin 680 597 Kerala

FROM,

AMITH KUMAR P,

ASSISTANT PROFESSOR,

EEE DEPARTMENT,

NCERC,

PAMPADY

TO,

THE PRINCIPAL,(THROUGH HOD)

EEE DEPARTMENT,

NCERC,

PAMPADY

Sir,

SUB: Requisition for conducting a certificate course on "EV Power Train"-Reg.

REF: Office circular No NCERC/3128/F/AC/09/16 dt.12-07-2016

I would like to request your support and permission to conduct a certificate course on "EV Power Train" on second and fourth Saturdays of the academic year 2016-17 without affecting class work. The duration of the course will be for a period of 30 hours. The objective of the course is to impart knowledge on latest developments in power trains. This course will act as a key for enhancing know how of students on power trains and for future career opportunities in field of electric vehicles

The 2013-17 batch admission(UG) of EEE department are eligible for this course.

So, I kindly request you to provide the permission for doing this certificate course.

Thank you for your consideration. I look forward for your response soon.

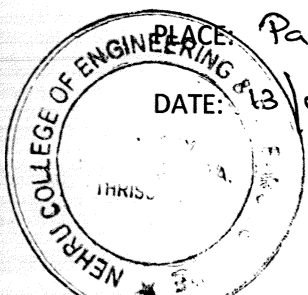

*Recommended & Forwarded*  
*Dhananayan*  
*Asst. Prof.*

Your's sincerely,  
*Amith*  
AMITH KUMAR P

**PRINCIPAL**  
Nehru College of  
Engineering and Research Center  
Pampady Thiruvilwamala, Thiruvananthapuram  
Pin - 680 607

**NEHRU COLLEGE OF ENGINEERING & RESEARCH CENTRE**  
(Accredited by NAAC)

**Pampady, Thiruvilwamala, Thrissur Dt.**

**ELECTRICAL AND ELECTRONICS DEPARTMENT**

**NOTICE**

**12.07.2016**

Department has decided to conduct a certificate course on **“EV Power Train “** on second and fourth Saturdays of the academic year 2016-17 without affecting class work. The duration of the course will be for a period of 30 hours. The objective of the course is to impart knowledge on latest developments in power trains. This course will act as a key for enhancing know how of students on power trains and for future career opportunities in field of electric vehicles

The 2013-17 batch admission(UG) of EEE department are eligible for this course. All concerned students should attend the entire course without fail. Attendance is compulsory.

Copy:

1. Department Notice Board
2. Staff advisors(For Information to students)
3. Office file



HoD

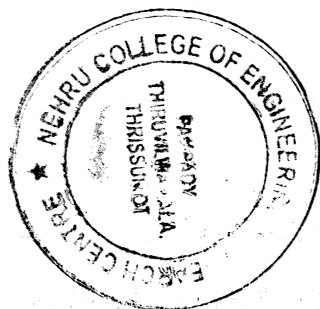

PRINCIPAL   
Nehru College of  
Engineering and Research Centre  
Pampady Thiruvilwamala Thrissur Dt  
Pin - 686 50, Kerala

**NEHRU COLLEGE OF ENGINEERING & RESEARCH CENTRE**  
(Accredited by NAAC)  
Pampady, Thiruvilwamala, Thrissur Dt.

**EV(POWER TRAIN)**

SYLLABUS

Lecture Modules	EV(POWER TRAIN)
1	Introduction to Electric Vehicles
2	Working of Power Trains
3	Architecture of Electric Vehicles
4	Simulation Exercise for Power Trains
5	Applications of EV
6	Optimization and configuration of of EV-Power Trains



Course Coordinator



HoD

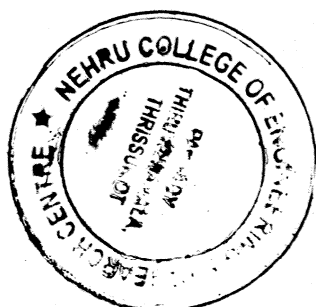

**PRINCIPAL**  
Nehru College of  
Engineering and Research Centre  
Pampady, Thiruvilwamala, Thrissur Dt  
Pin 680 597 Kerala

NEHRU COLLEGE OF ENGINEERING & RESEARCH CENTRE

(Accredited by NAAC)

Pampady, Thiruvilwamala, Thrissur Dt.

Certificate Course on "ELECTRICAL VEHICLE(POWER TRAIN)"

Electrical & Electronics Engineering(UG)- (2013-17)

ENROLLMENT LIST

NCANEEE049	NAYANA M S
NCANEEE050	NIKHIL KUMAR V
NCANEEE051	NOUSHIYA A
NCANEEE052	PRAVEEN K RAVINDRAN
NCANEEE053	RAHUL MOHAN
NCANEEE054	ROSHAN R
NCANEEE055	RUKHIYA FAHMIDHA
NCANEEE056	SALMAN P M
NCANEEE057	SANDESH VARMA E
NCANEEE058	SANJAY LAKSHMAN A
NCANEEE059	SARATH S
NCANEEE060	SARATH SASIDHARAN
NCANEEE061	SARATH SASIKUMAR
NCANEEE062	SHOBITH P
NCANEEE063	SIBIN C
NCANEEE064	SIDDHARTH KP
NCANEEE065	SONA JOHNSON
NCANEEE066	SOORAJ S
NCANEEE067	SOUGANDH K
NCANEEE068	SRINIDHI K.V
NCANEEE069	SUHAIL P P
NCANEEE070	SUKANNYA K S
NCANEEE071	SUSRUTHA DEV P
NCANEEE072	SWAYANA SELVAN
NCANEEE073	T.SREELAKSHMI
NCANEEE074	V SREERAM
NCANEEE075	VEENA T
NCANEEE076	VISHNU KR
NCANEEE077	VISHNU V
NCANEEE078	VYSAK SATHYANATH
NCANEEE079	YADAV K.S
NCANEEE080	YAJIN RAJAN

  
Course Coordinator

  
HoD

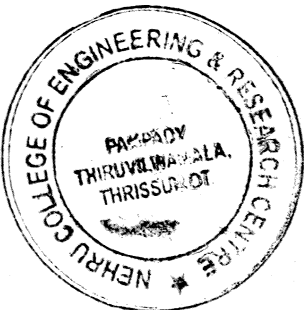

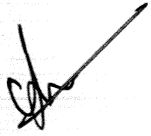

  
PRINCIPAL  
Nehru College of  
Engineering and Research Centre  
Pampady, Thiruvilwamala, Thrissur Dt  
Pin - 686 507, Kerala

NEHRU COLLEGE OF ENGINEERING & RESEARCH CENTRE  
(Accredited by NAAC)

Pampady, Thiruvilwamala, Thrissur Dt.  
Certificate Course on "ELECTRICAL VEHICLE(POWER TRAIN)"  
Electrical & Electronics Engineering(UG)- (2013-17)  
ENROLLMENT LIST

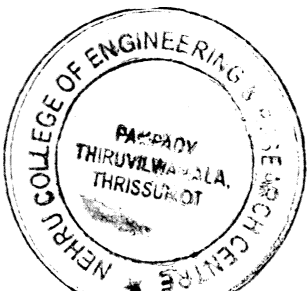
Reg.No.	Student Name
NCANEEE001	ABHIRAMI A.S
NCANEEE002	AISWARYA U
NCANEEE003	AISWARYA K P
NCANEEE004	AISWARYA M S
NCANEEE005	AJAY B
NCANEEE006	AJI GOPAL V
NCANEEE007	AJNA K I
NCANEEE008	AKARSH S
NCANEEE009	AKHIL ANAND
NCANEEE010	AKSHAY A
NCANEEE011	AKSHAY KUMAR
NCANEEE012	AKSHAY SATHIAN K
NCANEEE013	AMRITHA A B
NCANEEE014	AMRUTHA V.P
NCANEEE015	ANAGHA RADHAKRISHAN
NCANEEE016	ANANDRAJ K
NCANEEE017	ANJITHA MENON K G
NCANEEE018	ANOOP MU
NCANEEE019	ARYA T MADHU
NCANEEE020	ASHFAQUE P SAIF
NCANEEE021	ASHROOF A
NCANEEE022	ASWATHY R
NCANEEE023	ASWIN M
NCANEEE024	ATHIRA RAJAN
NCANEEE025	ATHUL KRISHNAN B
NCANEEE026	ATHUL SURESH
NCANEEE027	AVANEED VISHNU
NCANEEE028	DIVYA V
NCANEEE029	FIROSE K
NCANEEE030	GOKUL DAS R
NCANEEE031	GOKUL K
NCANEEE032	HARIKRISHNAN K
NCANEEE033	HATHIM AHAMED A P
NCANEEE034	JACXYMOL JAMES
NCANEEE035	JICKSON SAJU
NCANEEE036	JIJITHA U
NCANEEE037	JINO GEORGE M
NCANEEE038	JISHNU CHANDRAN
NCANEEE039	KAILAS A.P
NCANEEE040	ANILIN R
NCANEEE041	KIRAN K KANNAN
NCANEEE042	KUNISERRY CHEKINGAL VIPIN
NCANEEE043	LEDIYA JACOB
NCANEEE044	MADHUSOODANAN K
NCANEEE045	MANISH P
NCANEEE046	MINHAJ A S
NCANEEE047	MOHAMMED HAVAS V.A
NCANEEE048	NARENDRA PAI D



  
PRINCIPAL  
Nehru College of  
Engineering and Research Centre  
Pampady, Thiruvilwamala, Thrissur Dt  
Pin 680 557 Kerala

Register Number	Student Name	09-07-2016		23-07-2016		13-08-2016		27-08-2016		10-09-2016		24-09-2016	
		FN	AN	FN	AN	FN	AN	FN	AN	FN	AN	FN	AN
NCANEEE062	SHOBITH P	✓	✓	✓	✓	✓	✓	✓	✓	✓	✓	✓	✓
NCANEEE063	SIBIN C	✓	✓	✓	✓	✓	✓	✓	✓	✓	✓	✓	✓
NCANEEE064	SIDDHARTH KP	✓	✓	✓	✓	✓	✓	✓	✓	✓	✓	✓	✓
NCANEEE065	SONA JOHNSON	✓	✓	✓	✓	✓	✓	✓	✓	✓	✓	✓	✓
NCANEEE065	SOORAJ S	✓	✓	✓	✓	✓	✓	✓	✓	✓	✓	✓	✓
NCANEEE067	SOUGANDH K	✓	✓	✓	✓	✓	✓	✓	✓	✓	✓	✓	✓
NCANEEE068	SRINIDHI K.V	✓	✓	✓	✓	✓	✓	✓	✓	✓	✓	✓	✓
NCANEEE069	SUHAIL P P	✓	✓	✓	✓	✓	✓	✓	✓	✓	✓	✓	✓
NCANEEE070	SUKANNYA K S	✓	✓	✓	✓	✓	✓	✓	✓	✓	✓	✓	✓
NCANEEE071	SUSRUTHA DEV P	✓	✓	✓	✓	✓	✓	✓	✓	✓	✓	✓	✓
NCANEEE072	SWAYANA SELVAN	✓	✓	✓	✓	✓	✓	✓	✓	✓	✓	✓	✓
NCANEEE073	T.SREELAKSHMI	✓	✓	✓	✓	✓	✓	✓	✓	✓	✓	✓	✓
NCANEEE074	V SREERAM	✓	✓	✓	✓	✓	✓	✓	✓	✓	✓	✓	✓
NCANEEE075	VEENA T	✓	✓	✓	✓	✓	✓	✓	✓	✓	✓	✓	✓
NCANEEE076	VISHNU KR	✓	✓	✓	✓	✓	✓	✓	✓	✓	✓	✓	✓
NCANEEE077	VISHNU V	✓	✓	✓	✓	✓	✓	✓	✓	✓	✓	✓	✓
NCANEEE078	VYSAK SATHYANATH	✓	✓	✓	✓	✓	✓	✓	✓	✓	✓	✓	✓
NCANEEE079	YADAV K.S	✓	✓	✓	✓	✓	✓	✓	✓	✓	✓	✓	✓
NCANEEE080	YAJIN RAJAN	✓	✓	✓	✓	✓	✓	✓	✓	✓	✓	✓	✓

*[Signature]*

Course Coordinator

*[Signature]*

HoD

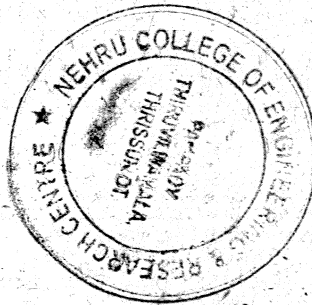

*[Signature]*  
**PRINCIPAL**  
 Nehru College of  
 Engineering and Research Centre  
 Panipady Thiruvilwamala, Thiruvananthapuram Dt  
 Pin - 686 597 Kerala

Register Numb	Student Name	09-07-2016		23-07-2016		13-08-2016		27-08-2016		10-09-2016		24-09-2016	
		FN	AN	FN	AN	FN	AN	FN	AN	FN	AN	FN	AN
NCANEEE054	ROSHAN R	✓	✓	✓	✓	✓	✓	✓	✓	✓	✓	✓	✓
NCANEEE055	RUKHIYA FAHMIDHA	✓	✓	✓	✓	✓	✓	✓	✓	✓	✓	✓	✓
NCANEEE056	SALMAN P M	✓	✓	✓	✓	✓	✓	✓	✓	✓	✓	✓	✓
NCANEEE057	SANDESH VARMA E	✓	✓	✓	✓	✓	✓	✓	✓	✓	✓	✓	✓
NCANEEE058	SANJAY LAKSHMAN A	✓	✓	✓	✓	✓	✓	✓	✓	✓	✓	✓	✓
NCANEEE059	SARATH S	✓	✓	✓	✓	✓	✓	✓	✓	✓	✓	✓	✓
NCANEEE060	SARATH SASIDHARAN	✓	✓	✓	✓	✓	✓	✓	✓	✓	✓	✓	✓
NCANEEE061	SARATH SASIKUMAR	✓	✓	✓	✓	✓	✓	✓	✓	✓	✓	✓	✓

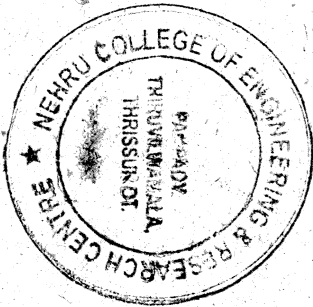

*[Signature]*  
**PRINCIPAL**  
 Nehru College of  
 Engineering and Research Centre  
 Panipady, Thiruvilwamala, Thiruvananthapuram  
 Pin 686 591, Kerala

Register Numb	Student Name	09-07-2016		23-07-2016		13-08-2016		27-08-2016		10-09-2016		24-09-2016	
		FN	AN	FN	AN	FN	AN	FN	AN	FN	AN	FN	AN
NCANEEE024	ATHIRA RAJAN	✓	✓	✓	✓	✓	✓	✓	✓	✓	✓	✓	✓
NCANEEE025	ATHUL KRISHNAN B	✓	✓	✓	✓	✓	✓	✓	✓	✓	✓	✓	✓
NCANEEE026	ATHUL SURESH	✓	✓	✓	✓	✓	✓	✓	✓	✓	✓	✓	✓
NCANEEE027	AVANEED VISHNU	✓	✓	✓	✓	✓	✓	✓	✓	✓	✓	✓	✓
NCANEEE028	DIVYA V	✓	✓	✓	✓	✓	✓	✓	✓	✓	✓	✓	✓
NCANEEE029	FIROSE K	✓	✓	✓	✓	✓	✓	✓	✓	✓	✓	✓	✓
NCANEEE030	GOKUL DAS R	✓	✓	✓	✓	✓	✓	✓	✓	✓	✓	✓	✓
NCANEEE031	GOKUL K	✓	✓	✓	✓	✓	✓	✓	✓	✓	✓	✓	✓
NCANEEE032	HARIKRISHNAN K	✓	✓	✓	✓	✓	✓	✓	✓	✓	✓	✓	✓
NCANEEE033	HATHIM AHAMED A P	✓	✓	✓	✓	✓	✓	✓	✓	✓	✓	✓	✓
NCANEEE034	JACXYMOL JAMES	✓	✓	✓	✓	✓	✓	✓	✓	✓	✓	✓	✓
NCANEEE035	JICKSON SAJU	✓	✓	✓	✓	✓	✓	✓	✓	✓	✓	✓	✓
NCANEEE036	JIJITHA U	✓	✓	✓	✓	✓	✓	✓	✓	✓	✓	✓	✓
NCANEEE037	JINO GEORGE M	✓	✓	✓	✓	✓	✓	✓	✓	✓	✓	✓	✓
NCANEEE038	JISHNU CHANDRAN	✓	✓	✓	✓	✓	✓	✓	✓	✓	✓	✓	✓
NCANEEE039	KAILAS A.P	✓	✓	✓	✓	✓	✓	✓	✓	✓	✓	✓	✓
NCANEEE040	ANILIN R	✓	✓	✓	✓	✓	✓	✓	✓	✓	✓	✓	✓
NCANEEE041	KIRAN K KANNAN	✓	✓	✓	✓	✓	✓	✓	✓	✓	✓	✓	✓
NCANEEE042	KUNISERRY CHEKINGAL VIPIN	AB	AB	AB	AB	AB	AB	AB	AB	AB	AB	AB	AB
NCANEEE043	LEDIYA JACOB	✓	✓	✓	✓	✓	✓	✓	✓	✓	✓	✓	✓
NCANEEE044	MADHUSOODANAN K	✓	✓	✓	✓	✓	✓	✓	✓	✓	✓	✓	✓
NCANEEE045	MANISH P	✓	✓	✓	✓	✓	✓	✓	✓	✓	✓	✓	✓
NCANEEE046	MINHAJ A S	✓	✓	✓	✓	✓	✓	✓	✓	✓	✓	✓	✓
NCANEEE047	MOHAMMED HAVAS V.A	✓	✓	✓	✓	✓	✓	✓	✓	✓	✓	✓	✓
NCANEEE048	NARENDRA PAI D	✓	✓	✓	✓	✓	✓	✓	✓	✓	✓	✓	✓
NCANEEE049	NAYANA M S	✓	✓	✓	✓	✓	✓	✓	✓	✓	✓	✓	✓
NCANEEE050	NIKHIL KUMAR V	✓	✓	✓	✓	✓	✓	✓	✓	✓	✓	✓	✓
NCANEEE051	NOUSHIYA A	✓	✓	✓	✓	✓	✓	✓	✓	✓	✓	✓	✓
NCANEEE052	DRAVEEN K RAVINDRAN	✓	✓	✓	✓	✓	✓	✓	✓	✓	✓	✓	✓
NCANEEE053	RAHUL MOHAN	AB	AB	AB	AB	AB	AB	AB	AB	AB	AB	AB	AB

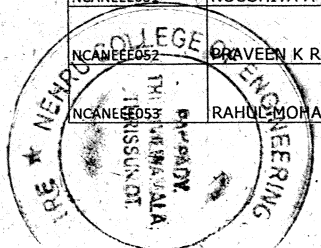

PRINCIPAL  
Nehru College of  
Engineering and Research Centre  
Thiruvananthapuram

NEHRU COLLEGE OF ENGINEERING & RESEARCH CENTRE

(Accredited by NAAC)

Pampady, Thiruvilwamala, Thrissur Dt.

Attendance Sheet for Certificate Course on "ELECTRICAL VEHICLE(POWER TRAIN)"

Electrical & Electronics Engineering(UG)- (2013-17)

Register Number	Student Name	09-07-2016		23-07-2016		13-08-2016		27-08-2016		10-09-2016		24-09-2016	
		FN	AN	FN	AN	FN	AN	FN	AN	FN	AN	FN	AN
NCANEEE001	ABHIRAMI A.S	✓	✓	✓	✓	✓	✓	✓	✓	✓	✓	✓	✓
NCANEEE002	AISWARYA U	✓	✓	✓	✓	✓	✓	✓	✓	✓	✓	✓	✓
NCANEEE003	AISWARYA K.P.	✓	✓	✓	✓	✓	✓	✓	✓	✓	✓	✓	✓
NCANEEE004	AISWARYA M.S	✓	✓	✓	✓	✓	✓	✓	✓	✓	✓	✓	✓
NCANEEE005	AJAY B	✓	✓	✓	✓	✓	✓	✓	✓	✓	✓	✓	✓
NCANEEE006	AJI GOPAL V	✓	✓	✓	✓	✓	✓	✓	✓	✓	✓	✓	✓
NCANEEE007	AJNA K I	✓	✓	✓	✓	✓	✓	✓	✓	✓	✓	✓	✓
NCANEEE008	AKARSH S	✓	✓	✓	✓	✓	✓	✓	✓	✓	✓	✓	✓
NCANEEE009	AKHIL ANAND	✓	✓	✓	✓	✓	✓	✓	✓	✓	✓	✓	✓
NCANEEE010	AKSHAY A	✓	✓	✓	✓	✓	✓	✓	✓	✓	✓	✓	✓
NCANEEE011	AKSHAY KUMAR	✓	✓	✓	✓	✓	✓	✓	✓	✓	✓	✓	✓
NCANEEE012	AKSHAY SATHIAN K	✓	✓	✓	✓	✓	✓	✓	✓	✓	✓	✓	✓
NCANEEE013	AMRITHA A B	✓	✓	✓	✓	✓	✓	✓	✓	✓	✓	✓	✓
NCANEEE014	AMRUTHA V.P	✓	✓	✓	✓	✓	✓	✓	✓	✓	✓	✓	✓
NCANEEE015	ANAGHA RADHAKRISHAN	✓	✓	✓	✓	✓	✓	✓	✓	✓	✓	✓	✓
NCANEEE016	ANANDRAJ K	✓	✓	✓	✓	✓	✓	✓	✓	✓	✓	✓	✓
NCANEEE017	ANJITHA MENON K G	✓	✓	✓	✓	✓	✓	✓	✓	✓	✓	✓	✓
NCANEEE018	ANOOP MU	✓	✓	✓	✓	✓	✓	✓	✓	✓	✓	✓	✓
NCANEEE019	ARYA T MADHU	✓	✓	✓	✓	✓	✓	✓	✓	✓	✓	✓	✓
NCANEEE020	ASHFAQUE P SAIF	✓	✓	✓	✓	✓	✓	✓	✓	✓	✓	✓	✓
NCANEEE021	ASHROOF A	<del>AB</del>	<del>AB</del>	<del>AB</del>	<del>AB</del>	<del>AB</del>	<del>AB</del>	<del>AB</del>	<del>AB</del>	<del>AB</del>	<del>AB</del>	<del>AB</del>	<del>AB</del>
NCANEEE022	ASWATHY	✓	✓	✓	✓	✓	✓	✓	✓	✓	✓	✓	✓
NCANEEE023	ASWATHY M	✓	✓	✓	✓	✓	✓	✓	✓	✓	✓	✓	✓

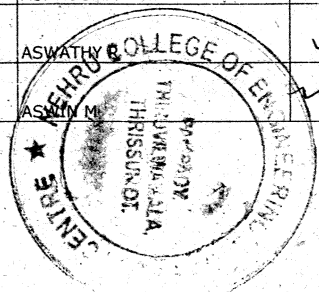

*[Signature]*  
**PRINCIPAL**  
 Nehru College of  
 Engineering and Research Centre  
 Pampady, Thiruvilwamala, Thrissur Dt

NEHRU COLLEGE OF ENGINEERING AND RESEARCH CENTRE  
(Accredited by NAAC)  
PAMPADY, THIRUVILWAMALA, THRISSUR (DT) – 680 588

EV-POWER TRAIN

ANSWER KEY

Question No.	Answer	Question No.	Answer
1	b	16	a
2	d	17	b
3	d	18	b
4	a	19	d
5	c	20	b
6	c	21	c
7	b	22	b
8	a	23	a
9	a	24	a
10	c	25	b
11	b	26	a
12	d	27	a
13	b	28	a
14	d	29	b
15	b	30	c

  
Course Coordinator

  
HOD

26. In a series hybrid:

- a). An electric motor acts as a backup to a gas engine.
- b). A gas engine and an electric motor alternately turn the wheels.
- c). A gas engine turns a generator, not the wheels.

27. Small engines are more efficient than large engines because: a). They weigh less.

- b). It takes less fuel to fill the cylinders.
- c). both A and B

28. In a Prius, the power split device connects the:

- a). gasoline engine, generator and electric motor
- b). gasoline engine, electric motor and power train
- c). gasoline engine, transmission and brakes

29. You should avoid abrupt stops in a hybrid car because:

- a). Hybrids are very sensitive to sudden changes in motion.
- b). The engine has more time to collect energy.
- c). Repairs to regenerative braking systems are extremely expensive.

30. A control strategy needed for present day EV trains is:

- a). Fast forward control
- b). Closed loop control
- c). Cascade control
- d). Feedback control

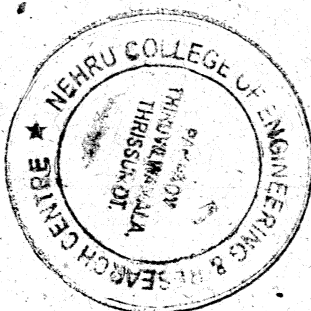

PRINCIPAL  
Nehru College of  
Engineering and Research Centre  
Pariipady, Thiruvananthapuram, Thiruvananthapuram, Kerala.  
Pin - 686 007, Kerala.

engine.

21. Select the cycle use in a Hybrid Engine. a) Otto  
b) Diesel c) Atkinson d) Isentropic

22. Select the WRONG statement.

a) Toyota produced the Insight Hybrid

b) Hybrid systems rely on very high voltages

c) All of the high voltage cables are covered in orange sleeves for easy identification d) To test high voltage systems you need a Category 3 (CAT III) digital volt ohmmeter

23. Select the CORRECT statement about Integrated Motor Assist (IMA) hybrid system a) Produced by Honda

b) This system is the basis for many series parallel hybrid vehicles.

c) This system is capable of instantaneously switching from one power source to another or combining the two.

24. The most common type of hybrid car combines the following: a) diesel and electric power

b) gas and electric power

c) biodiesel and electric power

25. In a parallel hybrid:

a) A gas engine runs an electric generator.

b) A gas engine and electric motor can each turn the wheels. c) The engine has no connection to the transmissions

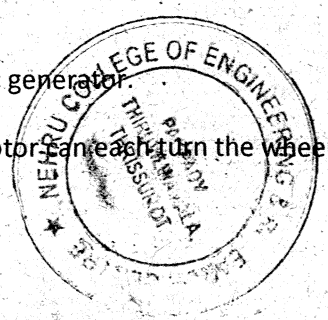

PRINCIPAL  
Nathan College of  
Engineering and Research Centre  
Pampady Thiruvilwamala, Thiruvananthapuram Dt  
Pin: 680 597 Kerala

14. "The wheels are driven by both the engine and the motor" Select the type of Hybrid System according to above description.

a). Series Hybrid  b). Parallel Hybrid c). Plug-in Hybrid

d). Series-parallel Hybrid

15. Select the features of Hybrid Electric Vehicles a). Idle Stop

b). EV Drive

c). Regenerative braking d). All the above.

16. The electric motor in a hybrid car can also act as :

a). cooling fan  b). fuel pump c). generator

d). None of the above

17. Regenerative braking involves :

a). Nano fibers that repair the surface of brake pads  b). reducing the amount of friction necessary to slow a car c). reclaiming heat from the brakes and using it for power

18. The benefits of a hybrid car include : a). reducing emissions

b). improving gas mileage c). high fuel consumption d). high speed driving

19. A

a). Mild Hybrid  b). Full Hybrid c). Fuel Cell

d). Assist Hybrid

20. A Toyota Prius C Hybrid has  a). 1

b). 2

c). half d). no

is a Hybrid source

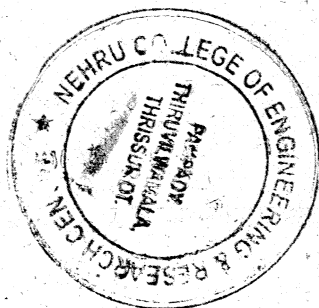

*cdh*  
**PRINCIPAL**

Nehru College of  
Engineering and Research Centre  
Thiruvananthapuram, Kerala

The series hybrid vehicle and the mild hybrid vehicle. The parallel hybrid vehicle and the full hybrid vehicle. The series hybrid vehicle and the parallel hybrid vehicle. The full hybrid vehicle and the empty hybrid vehicle.

9. Which sentence best describes a hybrid(parallel)vehicle?

The engine is directly connected to the transmission. X

The electric motor is directly connected to the transmission. Both of the above.

None of the above.

10. Which of these is a purpose of the power-split device?

To split electrical energy into mechanical energy.

To allow both the engine and electric motor to propel the vehicle. To recharge the battery while braking.

To recharge the brakes while driving.

11. Which of the following is NOT the type of Electric Hybrid Vehicle?

a) Plug-in Hybrid EV

b) Parallel Hybrid EV

c) Natural Gas For Vehicles

d) Series Hybrid EV

12. The Hybrid Electric Vehicle consists of :

a) NGV engine + Gasoline engine

b) IC engine + Gasoline engine

c) Electric motor+ Electric motor

d) IC engine+ Electric motor

13. "In this system, the engine is used to supply electrical power to the motor, which then turns the wheels" Select the type of Hybrid System according to above description.

a) Series Hybrid b) Parallel Hybrid c) Plug-in Hybrid

d) Series-parallel Hybrid

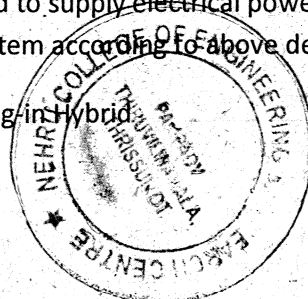

*Ch*  
**PRINCIPAL**  
Nehru College of  
Engineering and Research Centre  
Panipady Thiruvananthapuram, Thiruvananthapuram Dt

(C) A failed crankshaft position sensor

(D) A seized planetary gear set

4. During deceleration, of a power train the arrows on the power flow display appear as shown. This indicates:

(A) the engine is running with energy flowing to the drive wheels. ✓

~~(B)~~ the engine is running and driving the motor/generator to recharge the battery pack.

(C) energy from the battery pack and the engine are blended and flowing to the drive wheels.

(D) energy from the drive wheels is being used to recharge the battery pack.

5. A Type-2 hybrid vehicle with a belt-type continuously variable transmission (CVT) bucks and jerks when accelerating from a stop.

Technician A says that using the wrong type of transmission fluid could be the cause. Technician B says that a failing split pulley/steel belt could be the cause.

Who is right?

~~A) A only (C) Both A and B~~ ✗

(B) B only (D) Neither A nor B

6. The MIL is illuminated and a "Battery Module Deterioration" diagnostic trouble code (DTC) is stored. The most likely cause is a failed:

~~(A)~~ high voltage battery. ✓

(B) high voltage inverter.

(C) motor/generator.

(D) DC/DC converter.

7. What purpose does a generator serve in an EV power train? ✓

It converts nuclear energy into more nuclear energy. It converts mechanical energy into electrical energy. It converts chemical energy into electrical energy. ✓

It converts electrical energy into mechanical energy.

8. What are the two main types of electric (hybrid) vehicle? ✓

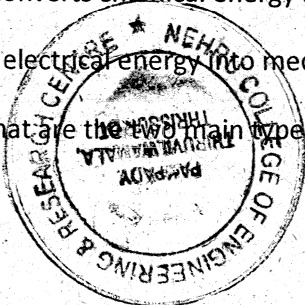

PRINCIPAL  
Nehru College of  
Engineering and Research Centre  
Panipady Thiruvilwamala, Thrissur  
Pin - 680 597 Kerala



NEHRU COLLEGE OF ENGINEERING AND RESEARCH CENTRE



(ACCREDITED BY NAAC)

PAMPADY, THIRUVILWAMALA, THRISSUR DIST.

CERTIFICATION COURSE EXAM

CERTIFICATION COURSE NAME: EV(POWER TRAINS)

Time: 1 Hr

Date: 24/9/16 Student Name: Sidharth Chandran

Department: Electrical And Electronics Engg.

27/30

Marks: 30

Reg. No.: NCA/NEET/038

1. An EV(power train) employs:

- (A) Cascade control
- (B) Fast forward control.
- (C) Feedback control.
- (D) Closed loop control

2. A control strategy that can be implemented during the given situation is:

Technician A says that a failed inverter coolant pump could be the cause.

Technician B says that insufficient coolant in the internal combustion engine (ICE) cooling system could be the cause.

Who is right?

- (A) A only
- (B) B only
- (C) Both A and B
- (D) Neither A nor B

3. A Type-1 EV will enter READY TO DRIVE (KOER) mode but will not crank the internal combustion engine (ICE). When the vehicle is pushed in NEUTRAL gear range, the engine spins. Which of these could be the cause?

- (A) A depleted high voltage battery
- (B) A seized MG2

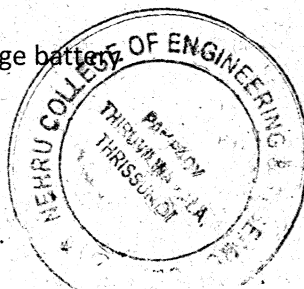

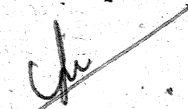
  
PRINCIPAL  
Nehru College of  
Engineering and Research Centre  
Pampady, Thiruvilwamala, Thirissur Dt.  
PIN: 686 597, Kerala

26. In a series hybrid:

- a). An electric motor acts as a backup to a gas engine.
- b). A gas engine and an electric motor alternately turn the wheels.
- c). A gas engine turns a generator, not the wheels.

27. Small engines are more efficient than large engines because: a). They weigh less.

- b). It takes less fuel to fill the cylinders.
- c). both A and B

28. In a Prius, the power split device connects the:

- a). gasoline engine, generator and electric motor
- b). gasoline engine, electric motor and power train
- c). gasoline engine, transmission and brakes

29. You should avoid abrupt stops in a hybrid car because:

- a). Hybrids are very sensitive to sudden changes in motion.
- b). The engine has more time to collect energy.
- c). Repairs to regenerative braking systems are extremely expensive.

30. A control strategy needed for present day EV trains is:

- (a) Fast forward control
- (b) Closed loop control
- (c) Cascade control
- (d) Feedback control

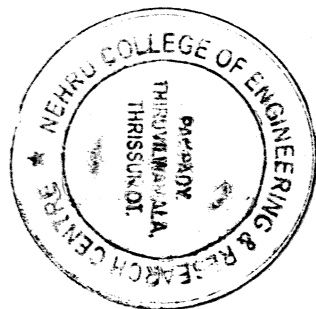

  
**PRINCIPAL**  
Nehru College of  
Engineering and Research Centre  
Pan-pady Thiruvilwamala, Thiruvananthapuram Dt  
Pin - 686 597 Kerala

engine.

21. Select the cycle use in a Hybrid Engine. a) Otto ✓

b) Diesel c) Atkinson d) Isentropic ✓

22. Select the WRONG statement.

a) ✓ Toyota produced the Insight Hybrid ✓

b) Hybrid systems rely on very high voltages ✓

c) All of the high voltage cables are covered in orange sleeves for easy identification d) To test high voltage systems you need a Category 3 (CAT III) digital volt ohmmeter ✓

23. Select the CORRECT statement about Integrated Motor Assist (IMA) hybrid system a) Produced by Honda ✓

b) ✓ This system is the basis for many series parallel hybrid vehicles. ✓

c) This system is capable of instantaneously switching from one power source to another or combining the two. ✓

24. The most common type of hybrid car combines the following: a) diesel and electric power ✓

b) ✓ gas and electric power ✓

c) biodiesel and electric power ✓

25. In a parallel hybrid:

a) ✓ A gas engine runs an electric generator. ✓

b) A gas engine and electric motor can each turn the wheels. c) The engine has no connection to the transmissions ✓

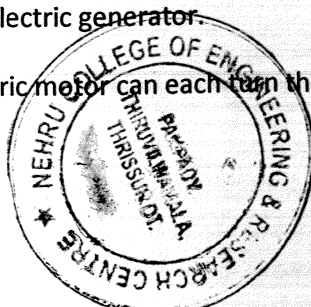

PRINCIPAL  
Nehru College of  
Engineering and Research Centre  
Palasady, Thiruvananthapuram, Thiruvananthapuram, Kerala

14. "The wheels are driven by both the engine and the motor" Select the type of Hybrid System according to above description.

- a). Series Hybrid
- b). Parallel Hybrid
- c). Plug-in Hybrid
- d). Series-parallel Hybrid

15. Select the features of Hybrid Electric Vehicles a). Idle Stop

- b). EV Drive
- c). Regenerative braking
- d). All the above.

16. The electric motor in a hybrid car can also act as :

- a). cooling fan
- b). fuel pump
- c). generator
- d). None of the above

17. Regenerative braking involves :

- a). Nano fibers that repair the surface of brake pads
- b). reducing the amount of friction necessary to slow a car
- c). reclaiming heat from the brakes and using it for power

18. The benefits of a hybrid car include : a). reducing emissions

- b). improving gas mileage
- c). high fuel consumption
- d). high speed driving

19. A

- a). Mild Hybrid
- b). Full Hybrid
- c). Fuel Cell
- d). Assist Hybrid

20. A Toyota Prius C Hybrid has a) 1

- b). 2
- c). half
- d). no

is a Hybrid source

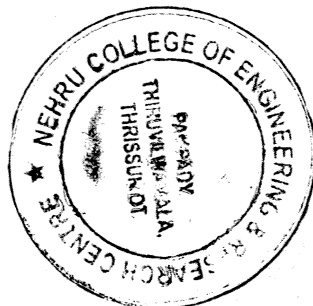

**PRINCIPAL**  
Nehru College of  
Engineering and Research Centre  
Pampady Thiruvilwamala, Thirissur  
Pin - 680 597 Kerala

The series hybrid vehicle and the mild hybrid vehicle. The parallel hybrid vehicle and the full hybrid vehicle. The series hybrid vehicle and the parallel hybrid vehicle. The full hybrid vehicle and the empty hybrid vehicle.

9. Which sentence best describes a hybrid(parallel)vehicle?

The engine is directly connected to the transmission.

The electric motor is directly connected to the transmission. Both of the above.

None of the above.

10. Which of these is a purpose of the power-split device?

To split electrical energy into mechanical energy.

To allow both the engine and electric motor to propel the vehicle. To recharge the battery while braking.

To recharge the brakes while driving.

11. Which of the following is NOT the type of Electric Hybrid Vehicle?

a) Plug-in Hybrid EV

b) Parallel Hybrid EV

c) Natural Gas For Vehicles

d) Series Hybrid EV

12. The Hybrid Electric Vehicle consists of :

a) NGV engine + Gasoline engine

b) IC engine + Gasoline engine

c) Electric motor+ Electric motor

d) IC engine+ Electric motor

13. "In this system, the engine is used to supply electrical power to the motor, which then turns the wheels" Select the type of Hybrid System according to above description.

a). Series Hybrid b). Parallel Hybrid c). Plug-in Hybrid

d). Series-parallel Hybrid

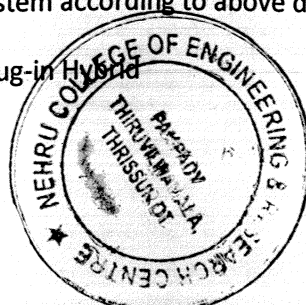

*Ch*  
**PRINCIPAL**  
Nehru College of  
Engineering and Research Centre  
Panipady Thiruvilwamala Thiruvananthapuram  
Pin: 686 56 Kerala

(C) A failed crankshaft position sensor

(D) A seized planetary gear set

4. During deceleration, of a power train the arrows on the power flow display appear as shown. This indicates:

(A) the engine is running with energy flowing to the drive wheels.

(B) the engine is running and driving the motor/generator to recharge the battery pack.

(C) energy from the battery pack and the engine are blended and flowing to the drive wheels.

(D) energy from the drive wheels is being used to recharge the battery pack.

5. A Type-2 hybrid vehicle with a belt-type continuously variable transmission (CVT) bucks and jerks when accelerating from a stop.

Technician A says that using the wrong type of transmission fluid could be the cause. Technician B says that a failing split pulley/steel belt could be the cause.

Who is right?

A) A only (C) Both A and B

X

(B) B only (D) Neither A nor B

6. The MIL is illuminated and a "Battery Module Deterioration" diagnostic trouble code (DTC) is stored. The most likely cause is a failed:

(A) high voltage battery.

(B) high voltage inverter.

(C) motor/generator.

(D) DC/DC converter.

7. What purpose does a generator serve in an EV power train?

It converts nuclear energy into more nuclear energy. It converts mechanical energy into electrical energy. It converts chemical energy into electrical energy.

It converts electrical energy into mechanical energy.

8. What are the two main types of electric(hybrid) vehicle?

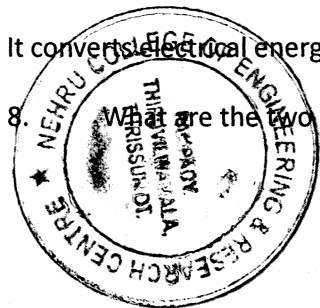

  
PRINCIPAL  
Nehru College of  
Engineering and Research Centre  
Panipady Thiruvilwamala, Thiruvananthapuram Dt  
Pin - 680 597 Kerala



NEHRU COLLEGE OF ENGINEERING AND RESEARCH CENTRE



(ACCREDITED BY NAAC)

PAMPADY, THIRUVILWAMALA, THRISSUR DIST.

CERTIFICATION COURSE EXAM

CERTIFICATION COURSE NAME: EV(POWER TRAINS)

28  
30

Time: 1 Hr

Marks: 30

Date: 24/9/16 Student Name: AKSHAY. A

Reg. No.: NCANR000010

Department: Electrical And Electronics Engg.

1. An EV(power train) employs:

- (A) Cascade control ✓  
(B) Fast forward control.  
(C) Feedback control. ✓  
(D) Closed loop control

2. A control strategy that can be implemented during the given situation is:

Technician A says that a failed inverter coolant pump could be the cause.

Technician B says that insufficient coolant in the internal combustion engine (ICE) cooling system could be the cause.

Who is right?

- (A) A only ✓  
(B) B only  
(C) Both A and B ✓  
(D) Neither A nor B

3. A Type-1 EV will enter READY TO DRIVE (KOER) mode but will not crank the internal combustion engine (ICE). When the vehicle is pushed in NEUTRAL gear range, the engine spins. Which of these could be the cause?

- (A) A depleted high voltage battery ✓  
(B) A seized MG2

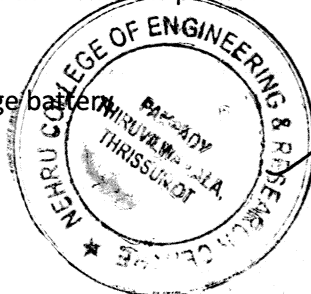

PRINCIPAL  
Nehru College of  
Engineering and Research Centre  
Pampady, Thiruvilwamala, Thirissur Dist.  
Pin - 680 597 Kerala

26. In a series hybrid:

- a). An electric motor acts as a backup to a gas engine.
- b). A gas engine and an electric motor alternately turn the wheels.
- c). A gas engine turns a generator, not the wheels.

27. Small engines are more efficient than large engines because: a). They weigh less.

- b). It takes less fuel to fill the cylinders.
- c). both A and B

28. In a Prius, the power split device connects the:

- a). gasoline engine, generator and electric motor
- b). gasoline engine, electric motor and power train
- c). gasoline engine, transmission and brakes

29. You should avoid abrupt stops in a hybrid car because:

- a). Hybrids are very sensitive to sudden changes in motion.
- b). The engine has more time to collect energy.
- c). Repairs to regenerative braking systems are extremely expensive.

30. A control strategy needed for present day EV trains is:

- a). Fast forward control
- b). Closed loop control
- c). Cascade control
- d). Feedback control

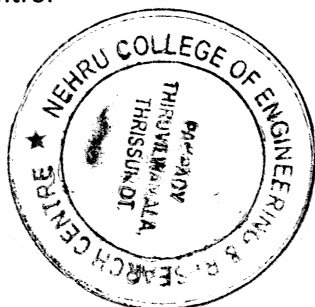

  
**PRINCIPAL**  
Nehru College of  
Engineering and Research Centre  
Pampady Thiruvilwamala Thiruvananthapuram  
Pin 686 59, Kerala

engine.

21. Select the cycle use in a Hybrid Engine. a). Otto ✓  
b). Diesel c). Atkinson d). Isentropic ✓

22. Select the WRONG statement.

a). ✓ Toyota produced the Insight Hybrid ✓

b). Hybrid systems rely on very high voltages ✓

c). All of the high voltage cables are covered in orange sleeves for easy identification d). To test high voltage systems you need a Category 3 (CAT III) digital volt ohmmeter ✓

23. Select the CORRECT statement about Integrated Motor Assist (IMA) hybrid system a). Produced by Honda ✓

b). ✓ This system is the basis for many series parallel hybrid vehicles. ✓

c). This system is capable of instantaneously switching from one power source to another or combining the two.

24. The most common type of hybrid car combines the following: a). diesel and electric power ✓

b). ✓ gas and electric power ✓

c). biodiesel and electric power

25. In a parallel hybrid:

a). ✓ A gas engine runs an electric generator ✓

b). A gas engine and electric motor can each turn the wheels. ✓ c). The engine has no connection to the transmissions ✓

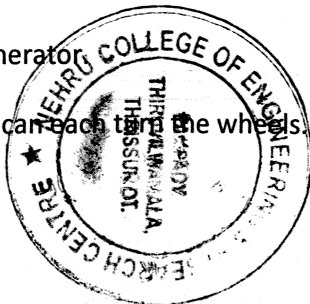

PRINCIPAL  
Nehru College of  
Engineering and Research Center  
Dhanuvarthy, Thiruvananthapuram, India

14. "The wheels are driven by both the engine and the motor" Select the type of Hybrid System according to above description.

- a). Series Hybrid ✓
- b). Parallel Hybrid ✓
- c). Plug-in Hybrid ✓
- d). Series-parallel Hybrid

15. Select the features of Hybrid Electric Vehicles a). Idle Stop

- b). EV Drive ✓
- c). Regenerative braking ✓
- d). All the above. ✓

16. The electric motor in a hybrid car can also act as :

- a). cooling fan ✓
- b). fuel pump ✓
- c). generator ✓
- d). None of the above ✓

17. Regenerative braking involves :

- a). Nano fibers that repair the surface of brake pads ✓
- b). reducing the amount of friction necessary to slow a car ✓
- c). reclaiming heat from the brakes and using it for power ✓

18. The benefits of a hybrid car include : a). reducing emissions ✓

- b). improving gas mileage ✓
- c). high fuel consumption ✓
- d). high speed driving ✓

19. A ✓

- a). Mild Hybrid ✓
- b). Full Hybrid ✓
- c). Fuel Cell ✓
- d). Assist Hybrid ✓

20. A Toyota Prius C Hybrid has a). 1 ✓

- b). 2 ✓
- c). half ✓
- d). no ✓

is a Hybrid source

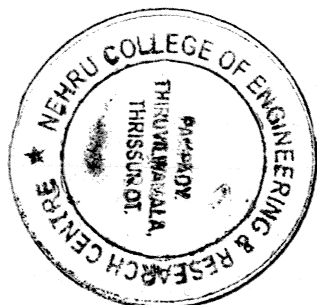

  
PRINCIPAL  
Nehru College of  
Engineering and Research Centre  
Pampady Thiruvilwamala, Thirissur, Ot  
Pin 680 597 Kerala

The series hybrid vehicle and the mild hybrid vehicle. The parallel hybrid vehicle and the full hybrid vehicle. The series hybrid vehicle and the parallel hybrid vehicle. The full hybrid vehicle and the empty hybrid vehicle.

9. Which sentence best describes a hybrid(parallel)vehicle?

The engine is directly connected to the transmission.

The electric motor is directly connected to the transmission. Both of the above.

None of the above.

10. Which of these is a purpose of the power-split device?

To split electrical energy into mechanical energy.

To allow both the engine and electric motor to propel the vehicle. To recharge the battery while braking.

To recharge the brakes while driving.

11. Which of the following is NOT the type of Electric Hybrid Vehicle?

- a) Plug-in Hybrid EV
- b) Parallel Hybrid EV
- c) Natural Gas For Vehicles
- d) Series Hybrid EV

12. The Hybrid Electric Vehicle consists of :

- a) NGV engine + Gasoline engine
- b) IC engine + Gasoline engine
- c) Electric motor+ Electric motor
- d) IC engine+ Electric motor

13. "In this system, the engine is used to supply electrical power to the motor, which then turns the wheels" Select the type of Hybrid System according to above description.

- a). Series Hybrid b). Parallel Hybrid c). Plug-in Hybrid
- d). Series-parallel Hybrid

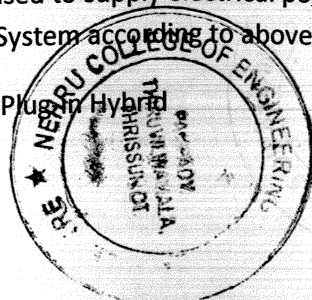

  
**PRINCIPAL**  
Nehru College of  
Engineering and Research Centre

(C) A failed crankshaft position sensor

(D) A seized planetary gear set

4. During deceleration, of a power train the arrows on the power flow display appear as shown. This indicates:

(A) the engine is running with energy flowing to the drive wheels.

✓ (B) the engine is running and driving the motor/generator to recharge the battery pack. ✓

(C) energy from the battery pack and the engine are blended and flowing to the drive wheels.

(D) energy from the drive wheels is being used to recharge the battery pack.

5. A Type-2 hybrid vehicle with a belt-type continuously variable transmission (CVT) bucks and jerks when accelerating from a stop.

Technician A says that using the wrong type of transmission fluid could be the cause. Technician B says that a failing split pulley/steel belt could be the cause.

Who is right?

✓ A) A only (C) Both A and B ✓

(B) B only (D) Neither A nor B

6. The MIL is illuminated and a "Battery Module Deterioration" diagnostic trouble code (DTC) is stored. The most likely cause is a failed:

✓ (A) high voltage battery. ✓

(B) high voltage inverter.

(C) motor/generator.

(D) DC/DC converter.

7. What purpose does a generator serve in an EV power train?

It converts nuclear energy into more nuclear energy. It converts mechanical energy into electrical energy. It converts chemical energy into electrical energy.

It converts electrical energy into mechanical energy.

8. What are the two main types of electric (hybrid) vehicle?

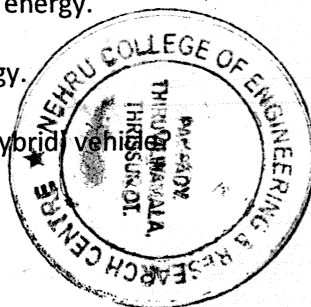

PRINCIPAL  
Nehru College of  
Engineering and Research Centre  
Pampady Thiruvilwamala Thiruvananthapuram  
Pin 680 597 Kerala



NEHRU COLLEGE OF ENGINEERING AND RESEARCH CENTRE



(ACCREDITED BY NAAC)

PAMPADY, THIRUVILWAMALA, THRISSUR DIST.

CERTIFICATION COURSE EXAM

CERTIFICATION COURSE NAME: EV(POWER TRAINS)

Time: 1 Hr

Date: 24/9/16 Student Name: KAILAS A.P

Department: Electrical And Electronics Engg.

29  
30

Marks: 30

Reg. No.: NCAWEL039

1. An EV(power train) employs:

- (A) Cascade control  
 (B) Fast forward control.  
 (C) Feedback control.  
 (D) Closed loop control

2. A control strategy that can be implemented during the given situation is:

Technician A says that a failed inverter coolant pump could be the cause.

Technician B says that insufficient coolant in the internal combustion engine (ICE) cooling system could be the cause.

Who is right?

- (A) A only  
 (B) B only  
 (C) Both A and B  
 (D) Neither A nor B

3. A Type-1 EV will enter READY TO DRIVE (KOER) mode but will not crank the internal combustion engine (ICE). When the vehicle is pushed in NEUTRAL gear range, the engine spins. Which of these could be the cause?

- (A) A depleted high voltage battery  
 (B) A seized MG2

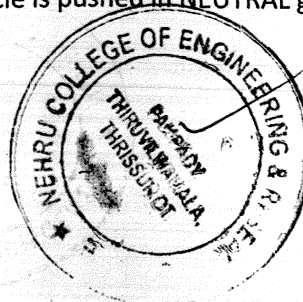

  
PRINCIPAL  
Nehru College of  
Engineering and Research Centre  
Pampady, Thiruvilwamala, Thris  
Pin 68

Reg.No.	Student Name	Marks/30
NCANEEE047	MOHAMMED HAVAS V.A	24
NCANEEE048	NARENDRA PAI D	25
NCANEEE049	NAYANA M S	25
NCANEEE050	NIKHIL KUMAR V	26
NCANEEE051	NOUSHIYA A	25
NCANEEE052	PRAVEEN K RAVINDRAN	26
NCANEEE053	RAHUL MOHAN	-A-
NCANEEE054	ROSHAN R	24
NCANEEE055	RUKHIYA FAHMIDHA	25
NCANEEE056	SALMAN P M	24
NCANEEE057	SANDESH VARMA E	27
NCANEEE058	SANJAY LAKSHMAN A	27
NCANEEE059	SARATH S	26
NCANEEE060	SARATH SASIDHARAN	25
NCANEEE061	SARATH SASIKUMAR	25
NCANEEE062	SHOBITH P	25
NCANEEE063	SIBIN C	24
NCANEEE064	SIDDHARTH KP	26
NCANEEE065	SONA JOHNSON	26
NCANEEE066	SOORAJ S	27
NCANEEE067	SOUGANDH K	24
NCANEEE068	SRINIDHI K.V	25
NCANEEE069	SUHAIL P P	22
NCANEEE070	SUKANNYA K S	23
NCANEEE071	SUSRUTHA DEV P	24
NCANEEE072	SWAYANA SELVAN	24
NCANEEE073	T.SREELAKSHMI	28
NCANEEE074	V SREERAM	24
NCANEEE075	VEENA T	25
NCANEEE076	VISHNU KR	25
NCANEEE077	VISHNU V	24
NCANEEE078	VYSAK SATHYANATH	26
NCANEEE079	YADAV K.S	25
NCANEEE080	YAJIN RAJAN	25

*Anitha*  
Course Coordinator

*Waseem*  
HoD



*Ch* PRINCIPAL  
Nehru College of  
Engineering and Research Centre,  
Panipady Thiruvilwamala, Thiruvananthapuram  
Pin - 686 597 Kerala

NEHRU COLLEGE OF ENGINEERING & RESEARCH CENTRE  
(Accredited by NAAC)  
Pampady, Thiruvilwamala, Thrissur Dt.  
Performance Sheet for Certificate Course on "ELECTRICAL VEHICLE(POWER TRAIN)"  
Electrical & Electronics Engineering(UG)- (2013-17)  
PERFORMANCE ANALYSIS

Reg.No.	Student Name	Marks/30
NCANEEE001	ABHIRAMI A.S	26
NCANEEE002	AISWARYA U	27
NCANEEE003	AISWARYA K P	27
NCANEEE004	AISWARYA M S	25
NCANEEE005	AJAY B	26
NCANEEE006	AJI GOPAL V	25
NCANEEE007	AJNA K I	28
NCANEEE008	AKARSH S	25
NCANEEE009	AKHIL ANAND	27
NCANEEE010	AKSHAY A	28
NCANEEE011	AKSHAY KUMAR	26
NCANEEE012	AKSHAY SATHIAN K	25
NCANEEE013	AMRITHA A B	26
NCANEEE014	AMRUTHA V.P	24
NCANEEE015	ANAGHA RADHAKRISHAN	28
NCANEEE016	ANANDRAJ K	22
NCANEEE017	ANJITHA MENON K G	24
NCANEEE018	ANOOP MU	23
NCANEEE019	ARYA T MADHU	25
NCANEEE020	ASHFAQUE P SAIF	23
NCANEEE021	ASHROOF A	-A-
NCANEEE022	ASWATHY R	26
NCANEEE023	ASWIN M	25
NCANEEE024	ATHIRA RAJAN	27
NCANEEE025	ATHUL KRISHNAN B	25
NCANEEE026	ATHUL SURESH	26
NCANEEE027	AVANEED VISHNU	26
NCANEEE028	DIVYA V	25
NCANEEE029	FIROSE K	24
NCANEEE030	GOKUL DAS R	24
NCANEEE031	GOKUL K	24
NCANEEE032	HARIKRISHNAN K	23
NCANEEE033	HATHIM AHAMED A P	21
NCANEEE034	JACXYMOL JAMES	23
NCANEEE035	JICKSON SAJU	24
NCANEEE036	JIJITHA U	26
NCANEEE037	JINO GEORGE M	25
NCANEEE038	JISHNU CHANDRAN	27
NCANEEE039	KAILAS A.P	29
NCANEEE040	ANILIN R	25
NCANEEE041	KIRAN K KANNAN	25
NCANEEE042	KUNISERRY CHEKINGAL VIPIN	-A-
NCANEEE043	LEDIYA JACOB	26
NCANEEE044	MADHUSOODANAN K	25
NCANEEE045	MANISH P	25
NCANEEE046	MINHAJ A S	24

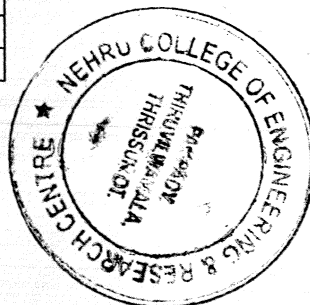

*Ch*  
**PRINCIPAL**  
Nehru College of  
Engineering and Research Centre  
Pampady Thiruvilwamala, Thr  
Pin - 686 507 Kerala



# NEHRU COLLEGE OF ENGINEERING AND RESEARCH CENTRE

(NAAC Accredited) (Approved by AICTE, Affiliated to Calicut University and A P J

Abdul Kalam Technological University, Kerala)

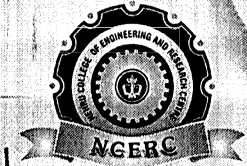

# CERTIFICATE

This is to Certify that Mr. V SREERAM of Electrical and Electronics Engineering Department has successfully completed the Certificate/Addon Course on ELECTRIC VEHICLE(POWER TRAIN)

from 09/07/2016 to 24/09/2016 at Nehru College of Engineering & Research Centre, Pamapdy.

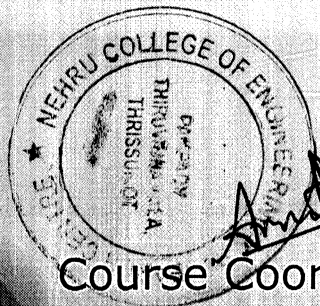

*[Signature]*  
Course Coordinator

*[Signature]*  
HOD  
EEE Department

*[Signature]*  
PRINCIPAL  
Nehru College of  
Engineering and Research Centre,  
Pamapdy Thiruvilwamala, Thiruvananthapuram,  
Kerala

*[Signature]*  
Principal  
NCERC



# NEHRU COLLEGE OF ENGINEERING AND RESEARCH CENTRE

(NAAC Accredited) (Approved by AICTE, Affiliated to Calicut University and A P J

Abdul Kalam Technological University, Kerala)



# CERTIFICATE

This is to Certify that Ms NOUSHIYA A of Electrical and Electronics Engineering Department has successfully completed the Certificate/Addon Course on ELECTRIC VEHICLE(POWER TRAIN)

from 09/07/2016 to 24/09/2016 at Nehru College of Engineering & Research Centre, Pamapdy.

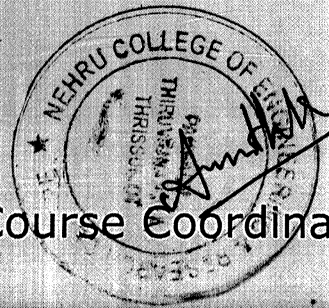

Course Coordinator

HoD

EEE Department

PRINCIPAL  
Nehru College of  
Engineering and Research Centre  
Pamapdy Thiruvilwamala Thiruvananthapuram  
620 507 1001

Principal  
NCERC



# NEHRU COLLEGE OF ENGINEERING AND RESEARCH CENTRE

(NAAC Accredited) (Approved by AICTE, Affiliated to Calicut University and A P J Abdul Kalam Technological University, Kerala)

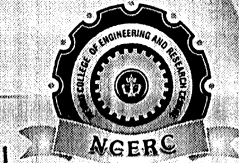

# CERTIFICATE

This is to Certify that Ms. ANJITHA MENON KG of Electrical and Electronics Engineering Department has successfully completed the Certificate/Addon Course on ELECTRIC VEHICLE (POWER TRAIN)

from 09/07/2016 to 24/09/2016 at Nehru College of Engineering & Research Centre, Pamapdy.

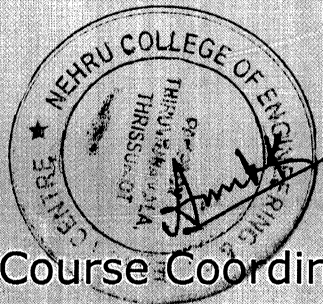

Course Coordinator

HoD  
EEE Department

PRINCIPAL  
Nehru College of  
Engineering and Research Centre  
Pamapdy Thiruvilwamala, Thiruvananthapuram  
Pin: 689 597 Kerala

Principal  
NCERC



# NEHRU COLLEGE OF ENGINEERING AND RESEARCH CENTRE

(NAAC Accredited) (Approved by AICTE, Affiliated to Calicut University and A P J Abdul Kalam Technological University, Kerala)

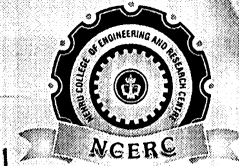

# CERTIFICATE

This is to Certify that Mr. AKSHAY KUMAR of Electrical and Electronics Engineering Department has successfully completed the Certificate/Addon Course on ELECTRIC VEHICLE (POWER TRAIN)

from 09/07/2016 to 24/09/2016 at Nehru College of Engineering & Research Centre, Pamapdy.

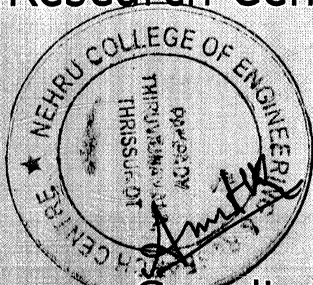

Course Coordinator

  
HoD

EEE Department

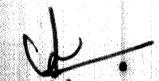
  
PRINCIPAL  
Nehru College of  
Engineering and Research Centre  
Pampady, Thiruvilwamala, Thrissur, Kerala  
Pin - 680 597

  
Principal  
NCERC



**NEHRU COLLEGE OF ENGINEERING AND RESEARCH CENTRE  
(NAAC Accredited)**

(Approved by AICTE, Affiliated to APJ Abdul Kalam Technological University, Kerala)



# **Mechanical Engineering**



# NEHRU COLLEGE OF ENGINEERING AND RESEARCH CENTRE

(NAAC Accredited) (Approved by AICTE, Affiliated to Calicut University and A P J Abdul Kalam Technological University, Kerala)

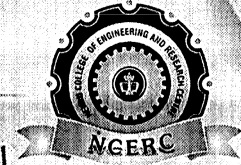

# CERTIFICATE

This is to Certify that Ms. AISWARYA U of Electrical and Electronics Engineering Department has successfully completed the Certificate/Addon Course on ELECTRIC VEHICLE (POWER TRAIN)

from 09/07/2016 to 24/09/2016 at Nehru College of Engineering & Research Centre, Pamapdy.

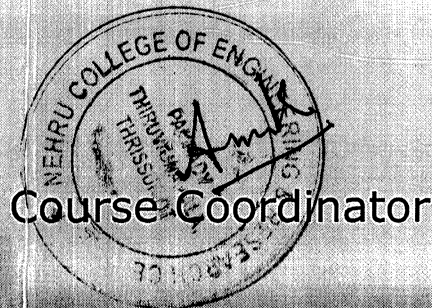

  
HoD  
EEE Department

  
PRINCIPAL  
Nehru College of  
Engineering and Research Centre  
Pampady, Thiruvilwamala, Thirissur Dist  
Pin 680 597 Kerala

  
Principal  
NCERC

**DEPARTMENT OF MECHANICAL ENGINEERING, NCERC, PAMPADY**

*(NAAC Accredited)*

**DEPARTMENT ADVISORY COMMITTEE MEETING MINUTES**

**Venue:** Mechanical HoD Room





**Date:** 15/07/2015

**Time:** 12.10 pm

**Agenda:**

- Introduction of certificate courses for the Academic Year 2015-16
- Any other matter

**Members Present**

- Prof. G Suresh, HOD 
- Prof. KB Javvarre Gowda, Professor 
- Dr.S Sankar, Asst. Professor 
- Mr. Sanoj T, Asst. Professor 
- Mr. Rixon K L, Asst. Professor 

**Minutes of the meeting:**

- HoD welcomed the members of Department advisory committee to the meeting.
- It was decided to conduct three certificate courses of 30 hour duration with an end course exam for all interested UG students in ME Dept.
- The course names and faculties handling the courses are decided to be:
  1. **ADVANCES IN ROBOTICS- Mr. Rixon K L**
  2. **ENTERPRISE RESOURCE PLANNING- Mr. Sanoj T**
  3. **CNC MAHINES, CONTROLS AND PART PROGRAMMING- Mr. Prashob M A**
- It was decided that the course 1 and 2 to be taken in Odd semester and course 3 to be taken in even semester of 2015-16 Academic Year.
- HoD instructed the faculties to fix the dates of commencement and get the permission from principal.

Meeting came to an end at 12.30pm.



  
**PRINCIPAL**  
Nehru College of  
Engineering and Research Centre  
Pampady, Thrissur District, Kerala  
Pin - 686 597, Kerala

From,

**Mr. Rixon K L**

Assistant Professor

Department Of Mechanical Engineering

Nehru College of Engineering and Research Centre

Pampady, Thrissur

To,

**The Principal**

Nehru College of Engineering and Research Centre

Pampady, Thrissur

Through HoD

Respected Sir,

**Sub: Permission to conduct certification courses during the academic year 2015-16-reg**

The Department of Mechanical Engineering is planning to conduct a 30 hour certification course on "ADVANCES IN ROBOTICS", scheduled during the months of August and September of this academic year 2015-16. The course is intended to be beneficial for students in their academics as well as professional life and therefore is offered to all B.Tech Mechanical Engineering students from 10/08/2015 onwards.

I humbly request you to kindly grant the permission for the same.

Thanking You

Place: Pampady

Date: 03/08/2015

Sincerely

*Rixon K L*  
Mr. Rixon K L

*Forwarded to HoD*  
*LM*

*Forwarded to principal*  
*[Signature]*  
03/08/15

*[Signature]*

*[Signature]*

PRINCIPAL  
Nehru College of  
Engineering and Research Centre  
Pampady, Thiruvithwamala, Thrissur Dt  
Pin 680 597 Kerala

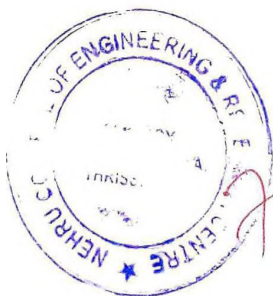



**NEHRU COLLEGE OF ENGINEERING AND RESEARCH  
CENTRE**

**(NAAC Accredited)**



(Approved by AICTE & Affiliated to University of Calicut and Kerala Technological University)

**DEPARTMENT OF MECHANICAL ENGINEERING**

**CIRCULAR**

**Date: 03/08/2015**

The Department of Mechanical Engineering is planning to conduct a 30 hour certification course on “**ADVANCES IN ROBOTICS**”, scheduled during the months of August and September of this academic year 2015-16. The course is intended to be beneficial for students in their academics as well as professional life and therefore is offered to all B.Tech Mechanical Engineering students from 10<sup>th</sup> August 2015 onwards. All students are hereby directed to enroll in the course mandatorily.

HoD,

*L. P. [Signature]*  
03/08/15  
Department of Mechanical Engineering

Copy to,

**Department Notice Board**

**To be read in all classes**



*[Signature]*  
**PRINCIPAL**  
Nehru College of  
Engineering and Research Centre  
Thiruvananthapuram, Kerala  
Ph: 966 707 1019



DEPARTMENT OF MECHANICAL ENGINEERING

**ADVANCES IN ROBOTICS**

**Year: 2015-16**

**Duration: 30 Hours**

**Pre-requisites:**

Nil

**Course Objectives:**

To give the Student:-

- To impart a general awareness about the structure and components and operation of robots
- To familiarize and understanding about different types of drives and sensors
- To develop analysis skills in kinematics and trajectory generation
- To impart programming skills and awareness about the role of a robot in an industry

**Syllabus:**

**Module 1**

Introduction to Robotics: Robot – Definition – Robot anatomy – Co-ordinate systems, work envelope, types and classification – Specifications – Pitch, yaw, roll, joint notations, speed of motion and pay load – Robot parts and their functions – Need for robots – Types, Parts, Functions, Different applications.

Robot Motion Analysis: Introduction to manipulator kinematics, homogeneous transformations and robot kinematics, manipulator path control, robot dynamics, configuration of a robot controller.

**Module 2**

Sensors in Robotics: Transducers and sensors, sensors in robotics, tactile sensors, proximity and range sensors, uses of sensors in robotics, problems. Machine Vision, : Introduction to machine vision, sensing and digitizing function in machine vision, image processing and analysis, training the vision system, robotic applications, problems.

**Module 3**

Robot End Effectors: types of end effecters, mechanical grippers, other types of grippers, tools as end effectors, robot/end effector interface, consideration in gripper selection and design, problems.

Pneumatic drives – Hydraulic drives – Mechanical drives – Electrical drives – D.C. servo motors, stepper motor and A.C. servo motors – Salient features, applications and comparison of all these drives.

**Module 4**

Robot Programming: Methods of robot programming, lead-through programming methods, a robot program as a path in space, motion interpolation, wait, signal and delay commands, branching, capabilities and limitations of lead-through methods, problems. Artificial Intelligence (AI): Introduction & goals of AI in research, AI techniques, LISP programming, AI & robotics, LISP in factory, robotic paradigms, and problems.

**Module 5**

Robots in Automatic Processing Operations: Introduction, spot welding, continuous arc welding, spray coating, other processing operations.

**PRINCIPAL**

Nehru College of  
Engineering and Research Centre  
Panipady Thiruvilwamala, Thrissur Dt.  
Pin - 686 197 Kerala

**Assembly & Inspection:** Assembly and robotic assembly automation, parts presentation methods, assembly operations, compliance and remote centre compliance (RCC) device, assembly system configurations, adaptable programmable assembly system, designing for robotic assembly, inspection automation.

**Course Outcome:**

Students who successfully complete this course will have an ability to understand the structure and components of robots; Apply the mathematical techniques to determine position and velocity of the end-effector, and determination of the forces and joint torques; Basic need and method of path planning is imparted; In addition to the fundamentals of robot programming; they also know the role of robots in an industry.

**References Books:**

1. John J Craig, Introduction to Robotics, Mechanics and Control, Third edition, Pearson Education International, 2005
2. Mark W. Spong & M. Vidyasagar, Robot Dynamics and Control, John Wiley & Sons, 2004
3. Mikell P. Groover et al, "Industrial Robots-Technology, Programming and Application". McGraw Hill Publishing Company-2013.
4. Yoram Koran, "Robotics for Engineers", McGraw-Hill International Student Edition, 2009

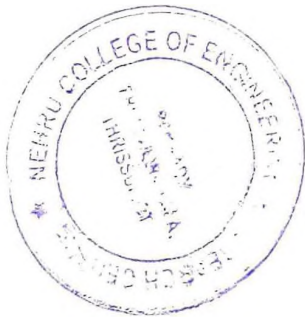

A handwritten signature in green ink, consisting of a stylized 'U' followed by a horizontal line.

PRINCIPAL  
Nehru College of  
Engineering and Research Centre  
Pampady Thiruvananthapuram  
Pin 680 597 Kerala

**NEHRU COLLEGE OF ENGINEERING AND RESEARCH CENTRE**  
*(NAAC Accredited, Affiliated to University of Calicut, Kerala Technological University)*  
**DEPARTMENT OF MECHANICAL ENGINEERING**

**ADVANCES IN ROBOTICS**

TOPICS	DATES
<b>MODULE 1</b>	
Robot, anatomy, coordinate system, work envelope	10/08/2015
Types , specifications, pitch, yaw, roll, joint notations	12/08/2015
Robot parts and functions, need, applications	12/08/2015
robot motion analysis	14-08-2015
robot dynamics	19-08-2015
Configuration of robotcontroller	19-08-2015
<b>MODULE 2</b>	
Transducers and sensors, tactile, proximity and range sensor	21-08-2015
Problems related to robotics	22-08-2015
Machine vision, sensing and digitilizing method,	22-08-2015
Robotics application, problems	25-08-2015
<b>MODULE 3</b>	
Types of robot end effectors	27-08-2015
mechanical grippers, tool as end effectors, end effector interface	01/09/2015
Gripper selection , problems	01/09/2015
Pneumatic, hydraulic, Mechanical drives	03/09/2015
DC servo motor, Stepper motor, AC Servo motor	07/09/2015
Features, Application and comparison of drives	07/09/2015
<b>MODULE 4</b>	
Robot programming lead through method	9/9/2015
Robot program as a path in space, motion interpolation	11/09/2015
Branching, capabilities and limitations of lead through programming	12/09/2015
Artificial intelligence, goals. TechniquesLISP programming,	12/09/2015
<b>MODULE 5</b>	
Robot automatic operation processes, spot welding , Continuous welding	9/15/2015
Spray painting, Robot assembly operation	9/18/2015
Parts presentation methods, RCC device, adaptable assembly system	9/19/2015
designing for robot assembly, inspection automation	9/21/2015
<b>End course Examination</b>	9/23/2015



  
**PRINCIPAL**

Nehru College of  
 Engineering and Research Centre  
 Pampad, Thrissur District, Kerala  
 Pin - 686 597 Kerala

**NEHRU COLLEGE OF ENGINEERING AND RESEARCH CENTRE, PAMPADY, THRISSUR**  
**DEPARTMENT OF MECHANICAL ENGINEERING**  
**ENROLLMENT LIST**

COURSE NAME: ADVANCES IN ROBOTICS  
 ACADEMIC YEAR: 2015-16  
 PROGRAM COORDINATOR: Mr. RIXON K L

SL.NO	REG NO	NAME	SL.NO	REG NO	NAME
1	NCAMEME001	ABDUL HASHIM V S	73	NCAMEME079	MUHAMMAD SHARIF V
2	NCAMEME004	ABHIJIT RAVI	74	NCAMEME081	NAIR JISHNU RAMACHANDRAN
3	NCAMEME002	ABHIJITH B	75	NCAMEME082	NAVEEN R
4	NCAMEME003	ABHIJITH K.U	76	NCAMEME083	NAVEEN ROSH V
5	NCAMEME005	ABHILASH A	77	NCAMEME086	NOEL THOMAS
6	NCAMEME006	ABHIMALECK GEORGE M	78	NCAMEME087	PRABHIJITH P
7	NCAMEME138	ABHINAV KRISHNAN	79	NCAMEME088	PRAJITH K S
8	NCAMEME007	ABIN VARGHESE V.P	80	NCAMEME091	PRANAV P S
9	NCAMEME139	ABU BACKER A	81	NCAMEME089	PRASHANTH PREMRAJ MENON
10	NCAMEME008	ACHUTH P	82	NCAMEME090	PREJIN P
11	NCAMEME009	ADARSH M	83	NCAMEME092	RAJESH R
12	NCAMEME010	ADARSH MURALI MENON	84	NCAMEME094	RENJITH C
13	NCAMEME011	AFFEEZ P.M	85	NCAMEME095	RENJITH MENON V.P
14	NCAMEME012	AFSHAD OMBAN	86	NCAMEME096	ROHITH R UNNI
15	NCAMEME013	AKHIL C K	87	NCAMEME098	SAJEEV C V
16	NCAMEME014	AKHIL C S	88	NCAMEME099	SALIM JAHANGEER
17	NCAMEME017	AKHIL PRASAD	89	NCAMEME101	SANIL SANKER A
18	NCAMEME016	AKHILESH R	90	NCAMEME102	SANJAY K S
19	NCAMEME019	AKSHAY M	91	NCAMEME103	SANJEER K
20	NCAMEME020	AKSHAY PRASAD H	92	NCAMEME104	SARATH K
21	NCAMEME022	ALEN M.A	93	NCAMEME106	SARATH P.R
22	NCAMEME143	AMAL DEV B	94	NCAMEME107	SHIHABUDHEEN.M.A
23	NCAMEME024	AMITH S	95	NCAMEME108	SIBI VIVIEK K.P
24	NCAMEME025	ANAND KOYILI	96	NCAMEME110	SOORAJ R NAIR
25	NCAMEME026	ANANTHA PADMANABHAN C.D	97	NCAMEME116	SREE VALLAB M
26	NCAMEME027	ANANTHA VISHNU M.H	98	NCAMEME112	SREEJITH S
27	NCAMEME140	ANFAR I	99	NCAMEME113	SREENATH NU
28	NCAMEME028	ANIRUDH K	100	NCAMEME114	SREERAJ P
29	NCAMEME029	ANOOOP K.V	101	NCAMEME117	SUDEV K.V
30	NCAMEME141	ANOOOP P.B	102	NCAMEME118	SUDHARSAN KRISHNAN
31	NCAMEME030	ANURAG K.B	103	NCAMEME146	SUDHEEP KUMAR K.M
32	NCAMEME031	ANVAR SADATH P	104	NCAMEME119	SUDHEEP P
33	NCAMEME032	ARAVIND M.R	105	NCAMEME120	SURAJ R PAI
34	NCAMEME033	ARAVIND PR	106	NCAMEME121	SWAROOP A
35	NCAMEME034	ARJUN A	107	NCAMEME122	SWATIN RAJ VR
36	NCAMEME035	ARJUN ARAVINDAKSHAN	108	NCAMEME123	THOMAS C DELSON
37	NCAMEME036	ARJUN DIVAKARAN K	109	NCAMEME124	TONY JOSE
38	NCAMEME037	ARJUN K.S	110	NCAMEME147	TONY TOM
39	NCAMEME038	ARON ANTONY	111	NCAMEME125	VINISH VIJAYAN PILLAI
40	NCAMEME039	ARUN C ANTONY	112	NCAMEME126	VIPIN K
41	NCAMEME040	ARUN TITUS	113	NCAMEME136	VISAK V.M.
42	NCAMEME041	ASHIQUE P.T	114	NCAMEME127	VISHNU C
43	NCAMEME043	ASWIN R	115	NCAMEME128	VISHNU C BALAN NAIR
44	NCAMEME044	BASIL EBRAHIM	116	NCAMEME129	VISHNU K
45	NCAMEME045	BHARATH K.B.	117	NCAMEME130	VISHNU K.H
46	NCAMEME046	BIPINDAS K.K	118	NCAMEME133	VISHNU RAJ.P
47	NCAMEME144	BRITTO CHERUVATHUR T	119	NCAMEME134	VISHNU SREEKUMAR
48	NCAMEME047	DHEERAJ K	120	NCAMEME131	VISHNULAL N.S
49	NCAMEME145	GOKUL DAS K.S	121	NCAMEME132	VISHNURAJ G.S
50	NCAMEME051	HARIDASAN K.P	122	NCAMEME135	VIVEK S PRASAD
51	NCAMEME052	HARIKRISHNAN U.	123	NCAMEME137	YADHUKRISHNAN T.M
52	NCAMEME054	HARILAL N			
53	NCAMEME055	HAROON AL.HADI S.K			
54	NCAMEME057	JAMSHEER P			
55	NCAMEME058	JAYADEV K			
56	NCAMEME060	JUNAID K.P			
57	NCAMEME061	JUNU FASIN			
58	NCAMEME062	KARNAN P RAYAROTH			
59	NCAMEME063	KUNJU MUHAMMED KY			
60	NCAMEME064	MATHEW KOSHY			
61	NCAMEME065	MEHROOF EBRAHY			
62	NCAMEME066	MIDHUN BALACHANDRAN			
63	NCAMEME068	MIJITH C			
64	NCAMEME069	MITHIL R			
65	NCAMEME072	MOHAMED SUAIB			
66	NCAMEME073	MOHAMMED AJMAL C			
67	NCAMEME074	MOHAMMED LABEEB T.K			
68	NCAMEME070	MOHAMMED SHABEEDUDHEEN K.M			
69	NCAMEME075	MOHAMMED SHEBIN K.B			
70	NCAMEME076	MUHAMMED ANZARI T			
71	NCAMEME077	MUHAMMED ASHIK			
72	NCAMEME078	MUHAMMED JASEER K.P.P			

*Dixon*

Mr.RIXON K L  
 PROGRAM COORDINATOR

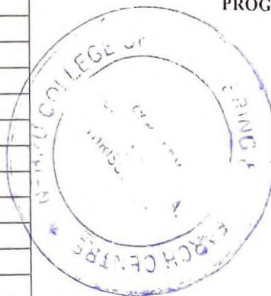

*U*

PRINCIPAL

Nehru College of  
 Engineering and Research Centre  
 Pampady, Pampady, Thrissur Dt  
 Kerala

**NEHRU COLLEGE OF ENGINEERING AND RESEARCH CENTRE, PAMPADY, THRISSUR  
DEPARTMENT OF MECHANICAL ENGINEERING  
ATTENDANCE REGISTER**

YEAR: 2015-16  
COURSE: ADVANCES IN ROBOTICS  
FACULTY-IN-CHARGE: Mr.RIXON K I.

Sl. No	Reg No	Name	August							DA September														
			10	12	14	19	21	22	23	25	27	1	3	7	11	12	12	15	16	19	21	23		
1	NCAMEME001	ABDUL HASHIM V S	/	/	/	/	/	/	/	/	/	/	/	/	/	/	/	/	/	/	/	/	/	/
2	NCAMEME004	ABHINI RAVI	/	/	/	/	/	/	/	/	/	/	/	/	/	/	/	/	/	/	/	/	/	/
3	NCAMEME002	ABHINI B	/	/	/	/	/	/	/	/	/	/	/	/	/	/	/	/	/	/	/	/	/	/
4	NCAMEME003	ABHINI K.U	/	/	/	/	/	/	/	/	/	/	/	/	/	/	/	/	/	/	/	/	/	/
5	NCAMEME005	ABHILASH A	/	/	/	/	/	/	/	/	/	/	/	/	/	/	/	/	/	/	/	/	/	/
6	NCAMEME006	ABHIMALICK GEORGE M	/	/	/	/	/	/	/	/	/	/	/	/	/	/	/	/	/	/	/	/	/	/
7	NCAMEME138	ABHINAV KRISHNAN	/	/	/	/	/	/	/	/	/	/	/	/	/	/	/	/	/	/	/	/	/	/
8	NCAMEME007	ABIN VARGHSE V.P	/	/	/	/	/	/	/	/	/	/	/	/	/	/	/	/	/	/	/	/	/	/
9	NCAMEME139	ABU BACKER A	/	/	/	/	/	/	/	/	/	/	/	/	/	/	/	/	/	/	/	/	/	/
10	NCAMEME008	ACHUTH P	/	/	/	/	/	/	/	/	/	/	/	/	/	/	/	/	/	/	/	/	/	/
11	NCAMEME009	ADARSH M	/	/	/	/	/	/	/	/	/	/	/	/	/	/	/	/	/	/	/	/	/	/
12	NCAMEME010	ADARSH MURALI MENON	/	/	/	/	/	/	/	/	/	/	/	/	/	/	/	/	/	/	/	/	/	/
13	NCAMEME011	AFFEEZ P.M	/	/	/	/	/	/	/	/	/	/	/	/	/	/	/	/	/	/	/	/	/	/
14	NCAMEME012	AFSHAD OMBAN	/	/	/	/	/	/	/	/	/	/	/	/	/	/	/	/	/	/	/	/	/	/
15	NCAMEME013	AKHIL C.K	/	/	/	/	/	/	/	/	/	/	/	/	/	/	/	/	/	/	/	/	/	/
16	NCAMEME014	AKHIL C.S	/	/	/	/	/	/	/	/	/	/	/	/	/	/	/	/	/	/	/	/	/	/
17	NCAMEME017	AKHIL PRASAD	/	/	/	/	/	/	/	/	/	/	/	/	/	/	/	/	/	/	/	/	/	/
18	NCAMEME016	AKHILESH R	/	/	/	/	/	/	/	/	/	/	/	/	/	/	/	/	/	/	/	/	/	/
19	NCAMEME019	AKSHAY M	/	/	/	/	/	/	/	/	/	/	/	/	/	/	/	/	/	/	/	/	/	/
20	NCAMEME020	AKSHAY PRASAD H	/	/	/	/	/	/	/	/	/	/	/	/	/	/	/	/	/	/	/	/	/	/
21	NCAMEME022	ALEN M.A	/	/	/	/	/	/	/	/	/	/	/	/	/	/	/	/	/	/	/	/	/	/
22	NCAMEME143	AMAL DEV B	/	/	/	/	/	/	/	/	/	/	/	/	/	/	/	/	/	/	/	/	/	/
23	NCAMEME024	AMITH S	/	/	/	/	/	/	/	/	/	/	/	/	/	/	/	/	/	/	/	/	/	/
24	NCAMEME025	ANAND KOYILI	/	/	/	/	/	/	/	/	/	/	/	/	/	/	/	/	/	/	/	/	/	/
25	NCAMEME026	ANANTHA PADMANABHAN	/	/	/	/	/	/	/	/	/	/	/	/	/	/	/	/	/	/	/	/	/	/
26	NCAMEME027	ANANTHA VISHNU M.H	/	/	/	/	/	/	/	/	/	/	/	/	/	/	/	/	/	/	/	/	/	/
27	NCAMEME140	ANFARI	/	/	/	/	/	/	/	/	/	/	/	/	/	/	/	/	/	/	/	/	/	/
28	NCAMEME028	ANIRUDH K	/	/	/	/	/	/	/	/	/	/	/	/	/	/	/	/	/	/	/	/	/	/
29	NCAMEME029	ANOOP K.V	/	/	/	/	/	/	/	/	/	/	/	/	/	/	/	/	/	/	/	/	/	/
30	NCAMEME141	ANOOP P.B	/	/	/	/	/	/	/	/	/	/	/	/	/	/	/	/	/	/	/	/	/	/
31	NCAMEME030	ANURAG K.B	/	/	/	/	/	/	/	/	/	/	/	/	/	/	/	/	/	/	/	/	/	/
32	NCAMEME031	ANVAR SADATH P	/	/	/	/	/	/	/	/	/	/	/	/	/	/	/	/	/	/	/	/	/	/
33	NCAMEME032	ARAVIND M.R	/	/	/	/	/	/	/	/	/	/	/	/	/	/	/	/	/	/	/	/	/	/
34	NCAMEME033	ARAVIND PR	/	/	/	/	/	/	/	/	/	/	/	/	/	/	/	/	/	/	/	/	/	/
35	NCAMEME034	ARJUN A	/	/	/	/	/	/	/	/	/	/	/	/	/	/	/	/	/	/	/	/	/	/
36	NCAMEME035	ARJUN ARAVINDAKSHAN	/	/	/	/	/	/	/	/	/	/	/	/	/	/	/	/	/	/	/	/	/	/
37	NCAMEME036	ARJUN DIVAKARAN K	/	/	/	/	/	/	/	/	/	/	/	/	/	/	/	/	/	/	/	/	/	/
38	NCAMEME037	ARJUN K.S	/	/	/	/	/	/	/	/	/	/	/	/	/	/	/	/	/	/	/	/	/	/
39	NCAMEME038	ARON ANTONY	/	/	/	/	/	/	/	/	/	/	/	/	/	/	/	/	/	/	/	/	/	/
40	NCAMEME039	ARUN C ANTONY	/	/	/	/	/	/	/	/	/	/	/	/	/	/	/	/	/	/	/	/	/	/
41	NCAMEME040	ARUN TITUS	/	/	/	/	/	/	/	/	/	/	/	/	/	/	/	/	/	/	/	/	/	/
42	NCAMEME041	ASHIQUE P.T	/	/	/	/	/	/	/	/	/	/	/	/	/	/	/	/	/	/	/	/	/	/
43	NCAMEME043	ASWIN R	/	/	/	/	/	/	/	/	/	/	/	/	/	/	/	/	/	/	/	/	/	/
44	NCAMEME044	BASIL EBRAHIM	/	/	/	/	/	/	/	/	/	/	/	/	/	/	/	/	/	/	/	/	/	/
45	NCAMEME045	BHARATH.K.B.	/	/	/	/	/	/	/	/	/	/	/	/	/	/	/	/	/	/	/	/	/	/
46	NCAMEME046	BIPINDAS K.K	/	/	/	/	/	/	/	/	/	/	/	/	/	/	/	/	/	/	/	/	/	/
47	NCAMEME144	BRITTO CHERUVATHUR T	/	/	/	/	/	/	/	/	/	/	/	/	/	/	/	/	/	/	/	/	/	/
48	NCAMEME047	DHEERAJ K	/	/	/	/	/	/	/	/	/	/	/	/	/	/	/	/	/	/	/	/	/	/
49	NCAMEME145	GOKUL DAS K.S	/	/	/	/	/	/	/	/	/	/	/	/	/	/	/	/	/	/	/	/	/	/
50	NCAMEME051	HARIDASAN K.P	/	/	/	/	/	/	/	/	/	/	/	/	/	/	/	/	/	/	/	/	/	/
51	NCAMEME052	HARIKRISHNAN U.	/	/	/	/	/	/	/	/	/	/	/	/	/	/	/	/	/	/	/	/	/	/
52	NCAMEME054	HARILAL N	/	/	/	/	/	/	/	/	/	/	/	/	/	/	/	/	/	/	/	/	/	/
53	NCAMEME055	HAROON AL HADI S.K	/	/	/	/	/	/	/	/	/	/	/	/	/	/	/	/	/	/	/	/	/	/
54	NCAMEME057	JAMISHEER P	/	/	/	/	/	/	/	/	/	/	/	/	/	/	/	/	/	/	/	/	/	/
55	NCAMEME058	JAY ADEV K	/	/	/	/	/	/	/	/	/	/	/	/	/	/	/	/	/	/	/	/	/	/
56	NCAMEME060	JUNAID K.P	/	/	/	/	/	/	/	/	/	/	/	/	/	/	/	/	/	/	/	/	/	/
57	NCAMEME061	JUNU FASIN	/	/	/	/	/	/	/	/	/	/	/	/	/	/	/	/	/	/	/	/	/	/
58	NCAMEME062	KARNAN P RAYAROTH	/	/	/	/	/	/	/	/	/	/	/	/	/	/	/	/	/	/	/	/	/	/
59	NCAMEME063	KUNJU MUHAMMED KY	/	/	/	/	/	/	/	/	/	/	/	/	/	/	/	/	/	/	/	/	/	/
60	NCAMEME064	MATHEW KOSHY	/	/	/	/	/	/	/	/	/	/	/	/	/	/	/	/	/	/	/	/	/	/
61	NCAMEME065	MEHROOF EBRAYI	/	/	/	/	/	/	/	/	/	/	/	/	/	/	/	/	/	/	/	/	/	/
62	NCAMEME066	MIDHUN BALACHANDRAN	/	/	/	/	/	/	/	/	/	/	/	/	/	/	/	/	/	/	/	/	/	/
63	NCAMEME068	MIJITH C	/	/	/	/	/	/	/	/	/	/	/	/	/	/	/	/	/	/	/	/	/	/
64	NCAMEME069	MITHIL R	/	/	/	/	/	/	/	/	/	/	/	/	/	/	/	/	/	/	/	/	/	/
65	NCAMEME072	MOHAMMED SUAIB	/	/	/	/	/	/	/	/	/	/	/	/	/	/	/	/	/	/	/	/	/	/
66	NCAMEME073	MOHAMMED AJMAL C	/	/	/	/	/	/	/	/	/	/	/	/	/	/	/	/	/	/	/	/	/	/
67	NCAMEME074	MOHAMMAD I ABLFB T.K	/	/	/	/	/	/	/	/	/	/	/	/	/	/	/	/	/	/	/	/	/	/
68	NCAMEME070	MOHAMMED SHABEEBU DHEEN	/	/	/	/	/	/	/	/	/	/	/	/	/	/	/	/	/	/	/	/	/	/

NEHRU COLLEGE OF ENGINEERING AND RESEARCH CENTRE  
PAMPADY, THRISSUR  
2015

**PRINCIPAL**  
Nehru College of  
Engineering and Research Centre  
Pampady, Thiruvananthapuram, Trissur (D)

Sl. No	Reg No	Name	DATES																							
			10	12	14	19	21	22	23	24	27	1	3	7	9	11	12	15	16	18	21	23				
69	NCAMEME075	MOHAMMID SHI BIN K.B	a	/	/	a	/	/	/	/	/	/	/	/	/	a	a	/	/	/	/	/	/			
70	NCAMEME076	MUHAMMID ANZARIT	/	/	/	/	/	/	/	/	/	a	/	/	/	/	/	/	/	/	/	/	/			
71	NCAMEME077	MUHAMMID ASHIK	/	/	a	/	/	/	/	/	/	/	/	/	/	/	/	/	/	/	/	/	/			
72	NCAMEME078	MUHAMMID JASLEER K.P.P	/	/	/	/	/	/	a	/	/	/	/	/	/	/	/	/	/	/	/	/	/			
73	NCAMEME079	MUHAMMID SHARIF V	/	/	a	/	/	/	/	/	/	/	/	/	/	/	/	/	/	/	/	/	/			
74	NCAMEME081	NAIR JISHNU RAMACHANDRAN	/	/	/	/	/	/	/	/	/	/	/	/	/	/	/	/	a	/	/	a	/			
75	NCAMEME082	NAVEEN R	/	/	/	/	/	/	a	/	/	/	a	/	a	/	/	/	/	/	/	/	/			
76	NCAMEME083	NAVEEN ROSH V	/	/	a	/	/	/	/	/	/	/	a	/	a	/	/	/	/	/	/	/	/			
77	NCAMEME086	NOEL THOMAS	/	/	/	/	/	/	/	/	/	/	/	/	/	/	/	/	/	/	/	/	/			
78	NCAMEME087	PRABHJITH P	/	/	/	/	/	/	/	/	/	/	/	/	/	/	/	/	/	/	/	/	/			
79	NCAMEME088	PRAJITH K.S	/	/	/	/	/	/	/	/	/	/	/	/	/	/	/	/	/	/	/	/	/			
80	NCAMEME091	PRANAV P.S	/	/	/	/	/	/	/	/	/	/	/	/	/	/	/	/	/	/	/	/	/			
81	NCAMEME089	PRASHANTH PREMRAJ MENON	/	/	/	/	/	/	/	/	/	/	/	/	/	/	a	/	/	/	/	/	/			
82	NCAMEME090	PREJIN P	/	/	/	/	/	/	/	/	/	/	/	/	/	/	/	a	/	/	/	/	/			
83	NCAMEME092	RAJESH R	a	a	a	/	/	/	/	/	/	/	/	/	/	/	/	/	/	/	/	/	/			
84	NCAMEME094	RENJITH C	a	/	/	/	/	/	/	/	a	/	/	/	/	/	/	/	/	/	/	/	a			
85	NCAMEME095	RENJITH MENON V.P	/	/	/	/	/	/	/	/	/	/	/	/	/	/	/	/	/	/	/	/	/			
86	NCAMEME096	ROHITH R UNNI	/	/	/	/	/	/	a	/	/	/	/	/	/	/	a	/	/	/	/	/	/			
87	NCAMEME098	SAJEEV C.V	/	/	/	/	/	/	/	/	/	/	/	/	/	/	/	/	/	a	/	/	/			
88	NCAMEME099	SALIM JAHANGEER	/	/	/	/	/	/	/	/	/	/	/	/	/	/	/	/	/	/	/	/	/			
89	NCAMEME101	SANIL SANKER A	/	/	/	/	/	/	/	/	a	/	/	/	/	/	/	/	/	/	/	/	/			
90	NCAMEME102	SANJAY K.S	a	/	/	/	/	/	/	/	/	/	/	/	/	/	/	/	/	a	/	/	/			
91	NCAMEME103	SANJEER K	/	/	/	/	/	/	/	/	/	/	/	/	/	/	/	/	/	/	/	/	/			
92	NCAMEME104	SARATH K	/	/	/	/	/	/	/	/	/	/	/	/	/	/	/	/	/	/	/	/	/			
93	NCAMEME106	SARATH P.R	/	/	/	/	/	/	/	/	a	/	/	/	/	/	/	/	/	/	/	/	/			
94	NCAMEME107	SHIHABUDHEEN.M.A	/	/	/	/	/	/	/	/	/	/	/	/	/	/	/	/	/	/	/	/	/			
95	NCAMEME108	SIBI VIVIEK K.P	/	/	/	/	/	/	/	/	/	/	/	/	/	/	/	/	/	/	/	/	/			
96	NCAMEME110	SOORAJ R NAIR	/	/	/	/	/	/	/	/	/	/	/	/	/	/	/	/	/	/	/	/	a			
97	NCAMEME116	SREE VALLAB M	/	/	/	/	/	/	/	/	/	/	/	/	/	/	/	/	/	/	/	/	/			
98	NCAMEME112	SREEJITH S	a	/	/	/	/	/	/	/	/	/	/	/	/	/	/	/	/	/	/	/	/			
99	NCAMEME113	SREENATH NU	/	/	/	/	/	/	/	/	/	/	/	/	/	/	/	/	/	/	/	/	/			
100	NCAMEME114	SREERAJ P	/	a	/	/	/	/	a	/	/	/	/	/	/	/	/	/	/	/	/	/	/			
101	NCAMEME117	SUDEV K.V	/	/	/	/	/	/	/	/	/	/	/	/	/	/	/	/	/	/	/	/	/			
102	NCAMEME118	SUDHARSAN KRISHNAN	/	/	/	/	/	/	/	/	/	/	/	/	/	/	/	/	/	/	/	/	/			
103	NCAMEME146	SUDHEEP KUMAR K.M	/	/	/	/	/	/	/	/	/	/	/	/	/	/	/	/	/	/	/	/	/			
104	NCAMEME119	SUDHEEP P	/	/	a	/	/	/	/	/	/	/	/	/	/	/	/	/	/	/	a	/	a			
105	NCAMEME120	SURAJ R PAI	a	/	a	/	/	/	/	/	/	/	/	/	/	/	/	/	/	/	/	/	/			
106	NCAMEME121	SWAROOP A	/	/	/	/	/	/	/	/	/	a	/	/	/	/	/	/	/	/	/	/	/			
107	NCAMEME122	SWATIN RAJ VR	/	/	/	/	/	/	/	/	/	/	/	/	/	/	/	/	/	/	/	/	/			
108	NCAMEME123	THOMAS C DELSON	/	/	/	a	/	a	/	/	/	/	a	/	/	/	/	/	/	/	/	/	/			
109	NCAMEME124	TONY JOSE	/	/	/	/	/	/	/	/	/	/	/	/	/	/	/	/	/	/	/	/	/			
110	NCAMEME147	TONY TOM	/	/	/	/	/	/	/	/	/	/	/	/	/	/	/	/	/	/	/	/	/			
111	NCAMEME125	VINISH VIJAYAN PILLAI	/	/	/	/	/	/	/	/	/	/	/	/	/	/	/	/	/	/	/	/	/			
112	NCAMEME126	VIPIN K	/	/	/	/	/	/	/	/	/	/	/	/	/	/	/	/	/	/	/	/	/			
113	NCAMEME136	VISAK.V.M.	/	/	/	/	/	/	/	/	/	/	/	/	/	/	a	/	/	/	/	/	/			
114	NCAMEME127	VISHNU C	/	/	/	/	/	/	/	/	/	/	/	/	/	/	/	/	/	/	/	/	/			
115	NCAMEME128	VISHNU C BALAN NAIR	/	a	/	/	/	/	/	/	/	/	/	/	/	/	/	/	/	/	/	/	/			
116	NCAMEME129	VISHNU K	/	/	/	/	/	/	/	/	/	/	/	/	/	/	/	/	/	/	/	/	/			
117	NCAMEME130	VISHNU K.H	/	/	/	/	/	/	/	/	/	/	/	/	/	/	/	/	/	/	/	/	/			
118	NCAMEME133	VISHNU RAJ.P	/	a	/	/	/	/	a	/	/	/	/	/	/	/	/	/	/	/	/	/	/			
119	NCAMEME134	VISHNU SREEKUMAR	/	/	a	/	/	/	/	/	/	/	/	/	/	/	/	/	/	/	/	/	/			
120	NCAMEME131	VISHNULAL N.S	/	/	/	/	/	/	/	/	/	/	/	/	/	/	/	/	/	/	/	/	/			
121	NCAMEME132	VISHNURAJ G.S	/	/	/	/	/	/	/	/	/	/	/	/	/	/	/	/	/	/	/	/	/			
122	NCAMEME135	VIVEK S PRASAD	/	/	/	/	/	/	/	/	/	/	/	/	/	/	/	/	/	/	/	/	/			
123	NCAMEME137	YADHUKRISHNAN T.M	a	/	/	/	/	/	/	/	/	/	/	/	/	/	/	/	/	/	/	/	/			

*[Signature]*  
FACULTY-IN-CHARGE



PRINCIPAL  
Vishnu College of  
Engineering and Technology  
Pampady, Thiruvananthapuram District,  
Kerala



NEHRU COLLEGE OF ENGINEERING AND RESEARCH CENTRE

(NAAC Accredited)

DEPARTMENT OF MECHANICAL ENGINEERING

END COURSE EXAMINATION



Course: **ADVANCES IN ROBOTICS**

Date: September 19, 2015

Academic Year: **2015-16**

Total Marks: **50**

Total Duration: **1 hour**

- Put a tick towards the right answer.
- If multiple options are chosen for a question it will not be considered for evaluation.
- Attend all the questions.
- There will be no negative marking.

Name: \_\_\_\_\_

Register Number: \_\_\_\_\_

Semester/Year: \_\_\_\_\_

*Each question carries 2 marks*

**1. What is the name for information sent from robot sensors to robot controllers?**

- a) temperature
- b) pressure
- c) feedback
- d) signal

**2. Which of the following terms refers to the rotational motion of a robot arm?**

- a) swivel
- b) axle
- c) retrograde
- d) roll

**3. What is the name for space inside which a robot unit operates?**

- a) environment
- b) spatial base
- c) work envelope
- d) exclusion zone

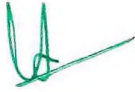

  
**PRINCIPAL**  
 Nehru College of  
 Engineering and Research Centre  
 Jampady, Thiruvikrama's, Thiruvananthapuram  
 P.O. Box 307, Kerala

4. Which of the following terms IS NOT one of the five basic parts of a robot?

- a) peripheral tools
- b) end effectors
- c) controller
- d) drive

5. Decision support programs are designed to help managers make \_\_\_\_\_

- a) budget projections
- b) visual presentations
- c) business decisions
- d) vacation schedules

6. PROLOG is an AI programming language which solves problems with a form of symbolic logic known as predicate calculus. It was developed in 1972 at the University of Marseilles by a team of specialists. Can you name the person who headed this team?

- a) Alain Colmerauer
- b) Niklaus Wirth
- c) Seymour Papert
- d) John McCarthy

7. The number of moveable joints in the base, the arm, and the end effectors of the robot determines \_\_\_\_\_

- a) degrees of freedom
- b) payload capacity
- c) operational limits
- d) flexibility

8. Which of the following places would be LEAST likely to include operational robots?

- a) warehouse
- b) factory
- c) hospitals
- d) private homes

9. For a robot unit to be considered a functional industrial robot, typically, how many degrees of freedom would the robot have?

- a) three
- b) four
- c) six
- d) eight

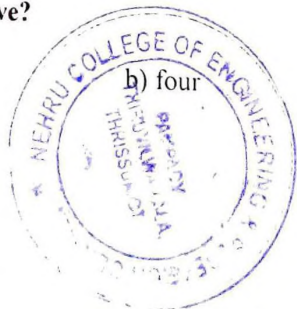

PRINCIPAL  
Nehru College of  
Engineering and Technology  
Thiruvananthapuram, Kerala, India

10. Which of the basic parts of a robot unit would include the computer circuitry that could be programmed to determine what the robot would do?

- a) sensor
- b) controller
- c) arm
- d) end effector

11. Which of the following terms refers to the use of compressed gasses to drive (power) the robot device?

- a) pneumatic
- b) hydraulic
- c) piezoelectric
- d) photosensitive

12. With regard to the physics of power systems used operate robots, which statement or statements are most correct?

- a) hydraulics involves the compression of liquids
- b) hydraulics involves the compression of air
- c) pneumatics involve the compression of air
- d) chemical batteries produce AC power

13. The original LISP machines produced by both LMI and Symbolics were based on research performed at

- a) CMU
- b) MIT
- c) Stanford University
- d) RAMD

14. Which of the following statements concerning the implementation of robotic systems is correct?

- a) implementation of robots CAN save existing jobs
- b) implementation of robots CAN create new jobs
- c) robotics could prevent a business from closing
- d) all of the mentioned

15. Which of the following IS NOT one of the advantages associated with a robotics implementation program?

- a) Low costs for hardware and software
- b) Robots work continuously around the clock
- c) Quality of manufactured goods can be improved

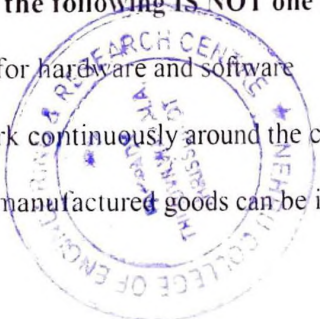

  
PRINCIPAL  
Nehru College of  
Engineering and Research Centre  
Pampaty, Thrissur District, Kerala

d) Reduced company cost for worker fringe benefits

16. Which of the following "laws" is Asimov's first and most important law of robotics?

a) robot actions must never result in damage to the robot

b) robots must never take actions harmful to humans

c) robots must follow the directions given by humans

d) robots must make business a greater profit

17. In LISP, the function returns t if <object> is a CONS cell and nil otherwise \_\_\_\_\_

a) (cons <object>)

b) (consp <object>)

c) (eq <object>)

d) (cous = <object>)

18. In a rule-based system, procedural domain knowledge is in the form of \_\_\_\_\_

a) production rules

b) rule interpreters

c) meta-rules

d) control rules

19. If a robot can alter its own trajectory in response to external conditions, it is considered to be \_\_\_\_\_

a) intelligent

b) mobile

c) open loop

d) non-servo

20. One of the leading American robotics centers is the Robotics Institute located at?

a) CMU

b) MIT

c) RAND

d) SRI

21. Which of the following is correct for proximity sensors?

a) Inductive type

b) Capacitive type

c) Ultrasonic wave type

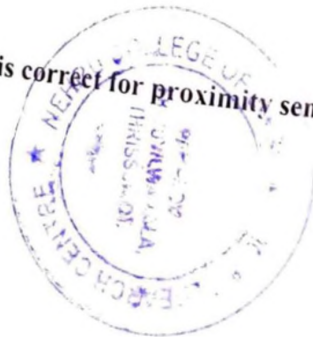

PRINCIPAL  
Nehru College of  
Engineering and Research Centre  
Thiruvananthapuram, Thiruvananthapuram  
Pin - 695 002 Kerala

d) All of the mentioned

**22. Which of the following person used the name robot first time in print?**

a) Josef capek

b) Karel capek

c) Isaac asimov

d) None of the mentioned

**23. Principles of cybernetics was developed by \_\_\_\_\_**

a) Josef capek

b) Norbert wiener

c) Isaac asimov

d) Karel capek

**24. Which of the following represents muscles of a robot?**

a) Actuators

b) Power supply

c) Micro controllers

d) Robotic arm

**25. ZMP stands for \_\_\_\_\_**

a) Zero movement power

b) Zero magnetic point

c) Zero moment point

d) Zero metric point



  
**PRINCIPAL**  
Nehru College of  
Engineering and Research Centre  
Panipat, Haryana - 131001  
Phone: 0150-2611111, 2611112  
Fax: 0150-2611113, 2611114  
E-mail: ncc@panipat.ac.in

# ADVANCES IN ROBOTICS

## ANSWER KEY

1. Answer: c
2. Answer: d
3. Answer: c
4. Answer: a
5. Answer: c
6. Answer: a
7. Answer: a
8. Answer: d
9. Answer: c
10. Answer: b
11. Answer: a
12. Answer: c
13. Answer: b
14. Answer: d
15. Answer: a
16. Answer: b
17. Answer: b
18. Answer: a
19. Answer: a
20. Answer: a
21. Answer: d
22. Answer: c
23. Answer: b
24. Answer: a
25. Answer: c



**PRINCIPAL**  
Nehru College of  
Engineering and Research Centre  
Pampady Thiruvilvamala Thrissur Dt  
Pin 680 597 Kerala



# NEHRU COLLEGE OF ENGINEERING AND RESEARCH CENTRE

(NAAC Accredited)

## DEPARTMENT OF MECHANICAL ENGINEERING

### END COURSE EXAMINATION

Course: **ADVANCES IN ROBOTICS**

Date: September 19, 2015

Academic Year: 2015-16

Total Marks: 50

Total Duration: 1 hour

- Put a tick towards the right answer.
- If multiple options are chosen for a question it will not be considered for evaluation.
- Attend all the questions.
- There will be no negative marking.

34/50

Name: Abdul Hashim VS

Register Number: NCAMEMF001

Semester/Year: 7/4

Each question carries 2 marks

1. What is the name for information sent from robot sensors to robot controllers?

- a) temperature
- b) pressure
- c) feedback ✓
- d) signal

2. Which of the following terms refers to the rotational motion of a robot arm?

- a) swivel ✓
- b) axle ✗
- c) retrograde
- d) roll

3. What is the name for space inside which a robot unit operates?

- a) environment
- b) spatial base
- c) work envelope ✓
- d) exclusion zone



*[Signature]*  
 PRINCIPAL  
 Nehru College of  
 Engineering and Research Centre  
 Thiruvananthapuram, Kerala

4. Which of the following terms IS NOT one of the five basic parts of a robot?

- a) peripheral tools ✓
- b) end effectors
- c) controller
- d) drive

5. Decision support programs are designed to help managers make \_\_\_\_\_

- a) budget projections
- b) visual presentations
- c) business decisions ✓
- d) vacation schedules

6. PROLOG is an AI programming language which solves problems with a form of symbolic logic known as predicate calculus. It was developed in 1972 at the University of Marseilles by a team of specialists. Can you name the person who headed this team?

- a) Alain Colmerauer
- b) Niklaus Wirth ✓
- c) Seymour Papert
- d) John McCarthy

7. The number of moveable joints in the base, the arm, and the end effectors of the robot determines \_\_\_\_\_

- a) degrees of freedom ✓
- b) payload capacity
- c) operational limits
- d) flexibility

8. Which of the following places would be LEAST likely to include operational robots?

- a) warehouse
- b) factory
- c) hospitals
- d) private homes ✓

9. For a robot unit to be considered a functional industrial robot, typically, how many degrees of freedom would the robot have?

- a) three
- b) four
- c) six ✓
- d) eight

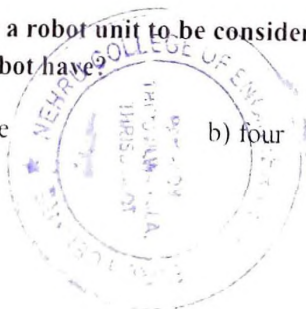

PRINCIPAL  
Nehru College of  
Engineering and Research Center  
Durgam Cheruvu, Hyderabad  
Ph: 899 26 6000

10. Which of the basic parts of a robot unit would include the computer circuitry that could be programmed to determine what the robot would do?

- a) sensor
- b) controller
- c) arm ✓
- d) end effector

11. Which of the following terms refers to the use of compressed gasses to drive (power) the robot device?

- a) pneumatic ✓
- b) hydraulic
- c) piezoelectric
- d) photosensitive

12. With regard to the physics of power systems used operate robots, which statement or statements are most correct?

- a) hydraulics involves the compression of liquids
- b) hydraulics involves the compression of air
- c) pneumatics involve the compression of air ✓
- d) chemical batteries produce AC power ✓

13. The original LISP machines produced by both LMI and Symbolics were based on research performed at

- a) CMU
- b) MIT ✓
- c) Stanford University
- d) RAMD

14. Which of the following statements concerning the implementation of robotic systems is correct?

- a) implementation of robots CAN save existing jobs
- b) implementation of robots CAN create new jobs
- c) robotics could prevent a business from closing
- d) all of the mentioned ✓

15. Which of the following IS NOT one of the advantages associated with a robotics implementation program?

- a) Low costs for hardware and software ✓
- b) Robots work continuously around the clock
- c) Quality of manufactured goods can be improved

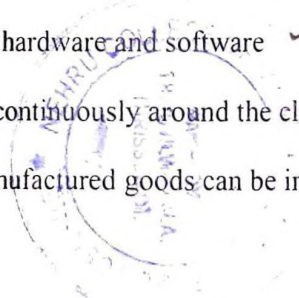

PRINCIPAL  
Nehru College of  
Engineering and Research Centre  
Mambady, Thrissur, Kerala  
Pin - 686 001, K. India

d) Reduced company cost for worker fringe benefits

16. Which of the following "laws" is Asimov's first and most important law of robotics?

a) robot actions must never result in damage to the robot

b) robots must never take actions harmful to humans ✓

c) robots must follow the directions given by humans

d) robots must make business a greater profit

17. In LISP, the function returns t if <object> is a CONS cell and nil otherwise \_\_\_\_\_

a) (cons <object>)

b) (consp <object>)

c) (eq <object>) ✓

d) (cous = <object>)

18. In a rule-based system, procedural domain knowledge is in the form of \_\_\_\_\_

a) production rules ✓

b) rule interpreters

c) meta-rules

d) control rules

19. If a robot can alter its own trajectory in response to external conditions, it is considered to be \_\_\_\_\_

a) intelligent ✓

b) mobile

c) open loop

d) non-servo

20. One of the leading American robotics centers is the Robotics Institute located at?

a) CMU ✓

b) MIT

c) RAND

d) SRI

21. Which of the following is correct for proximity sensors?

a) Inductive type

b) Capacitive type

c) Ultrasonic wave type

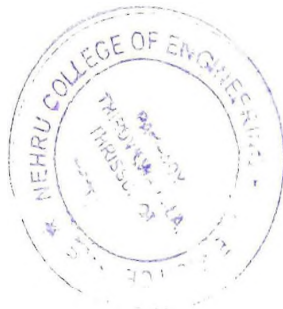

PRINCIPAL  
Nehru College of  
Engineering and Research Centre  
Thrippady, Thrissur, Kerala  
Pin: 686 502, Kerala

d) All of the mentioned ✓

22. Which of the following person used the name robot first time in print?

a) Josef capek

b) Karel capek ✓

c) Isaac asimov

d) None of the mentioned

23. Principles of cybernetics was developed by \_\_\_\_\_

a) Josef capek

b) Norbert wiener ✓

c) Isaac asimov

d) Karel capek

24. Which of the following represents muscles of a robot?

a) Actuators ✓

b) Power supply

c) Micro controllers

d) Robotic arm

25. ZMP stands for \_\_\_\_\_

a) Zero movement power

b) Zero magnetic point

c) Zero moment point ✓

d) Zero metric point

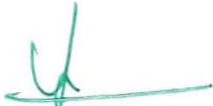

  
PRINCIPAL  
Nehru College of  
Engineering and Research Centre  
Warananasi, Warananasi, Warananasi



NEHRU COLLEGE OF ENGINEERING AND RESEARCH CENTRE

(NAAC Accredited)

DEPARTMENT OF MECHANICAL ENGINEERING

END COURSE EXAMINATION



Course: **ADVANCES IN ROBOTICS**

Date: September 19, 2015

Academic Year: **2015-16**

Total Marks: **50**

Total Duration: **1 hour**

- Put a tick towards the right answer.
- If multiple options are chosen for a question it will not be considered for evaluation.
- Attend all the questions.
- There will be no negative marking.

Name: JAMSHEER P

Register Number: NCAMEME057

Semester/Year: VII/IV

41/1/50

*Each question carries 2 marks*

1. What is the name for information sent from robot sensors to robot controllers?

- a) temperature
- b) pressure
- c) feedback ✓
- d) signal

2. Which of the following terms refers to the rotational motion of a robot arm?

- a) swivel
- b) axle
- c) retrograde
- d) roll ✓

3. What is the name for space inside which a robot unit operates?

- a) environment
- b) spatial base
- c) work envelope ✓
- d) exclusion zone

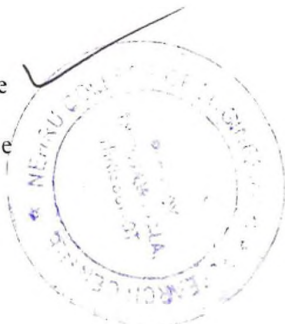

*[Signature]*

PRINCIPAL  
Neeru College of  
Engineering and Research Centre  
Pattipady, Tamil Nadu, India  
Pin: 629 001, Pondicherry

4. Which of the following terms IS NOT one of the five basic parts of a robot?

- a) peripheral tools ✓
- b) end effectors
- c) controller
- d) drive

5. Decision support programs are designed to help managers make \_\_\_\_\_

- a) budget projections
- b) visual presentations
- c) business decisions ✓
- d) vacation schedules

6. PROLOG is an AI programming language which solves problems with a form of symbolic logic known as predicate calculus. It was developed in 1972 at the University of Marseilles by a team of specialists. Can you name the person who headed this team?

- a) Alain Colmerauer ✓
- b) Niklaus Wirth
- c) Seymour Papert
- d) John McCarthy

7. The number of moveable joints in the base, the arm, and the end effectors of the robot determines \_\_\_\_\_

- a) degrees of freedom ✓
- b) payload capacity
- c) operational limits
- d) flexibility

8. Which of the following places would be LEAST likely to include operational robots?

- a) warehouse
- b) factory
- c) hospitals
- d) private homes ✓

9. For a robot unit to be considered a functional industrial robot, typically, how many degrees of freedom would the robot have?

a) three

b) four ✓

c) six

d) eight ✓

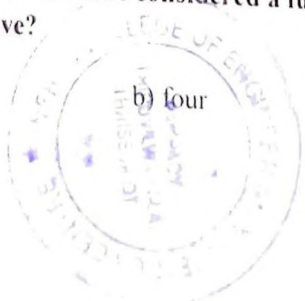

Handwritten notes in green ink at the bottom right of the page, including a signature and some illegible text.

10. Which of the basic parts of a robot unit would include the computer circuitry that could be programmed to determine what the robot would do?

- a) sensor
- b) controller ✓
- c) arm
- d) end effector

11. Which of the following terms refers to the use of compressed gasses to drive (power) the robot device?

- a) pneumatic ✓
- b) hydraulic
- c) piezoelectric
- d) photosensitive

12. With regard to the physics of power systems used operate robots, which statement or statements are most correct?

- a) hydraulics involves the compression of liquids
- b) hydraulics involves the compression of air
- c) pneumatics involve the compression of air
- d) chemical batteries produce AC power ✓

13. The original LISP machines produced by both LMI and Symbolics were based on research performed at

- a) CMU
- b) MIT ✓
- c) Stanford University
- d) RAMD

14. Which of the following statements concerning the implementation of robotic systems is correct?

- a) implementation of robots CAN save existing jobs
- b) implementation of robots CAN create new jobs
- c) robotics could prevent a business from closing
- d) all of the mentioned ✓

15. Which of the following IS NOT one of the advantages associated with a robotics implementation program?

- a) Low costs for hardware and software ✓
- b) Robots work continuously around the clock
- c) Quality of manufactured goods can be improved

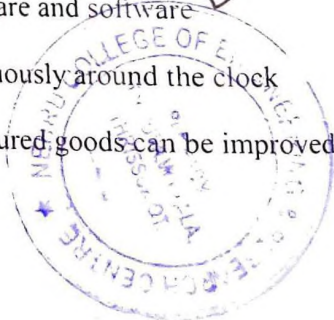

  
 PRINCIPAL  
 Nehru College of  
 Engineering and Research Centre  
 Pimpri, Maharashtra  
 Ph: 020-2711-1007

d) Reduced company cost for worker fringe benefits

16. Which of the following "laws" is Asimov's first and most important law of robotics?

a) robot actions must never result in damage to the robot

b) robots must never take actions harmful to humans ✓

c) robots must follow the directions given by humans

d) robots must make business a greater profit

17. In LISP, the function returns t if <object> is a CONS cell and nil otherwise \_\_\_\_\_

a) (cons <object>)

b) (consp <object>) ✓

c) (eq <object>)

d) (cous = <object>)

18. In a rule-based system, procedural domain knowledge is in the form of \_\_\_\_\_

a) production rules ✓

b) rule interpreters

c) meta-rules

d) control rules

19. If a robot can alter its own trajectory in response to external conditions, it is considered to be \_\_\_\_\_

a) intelligent ✓

b) mobile

c) open loop

d) non-servo

20. One of the leading American robotics centers is the Robotics Institute located at?

a) CMU ✓

b) MIT

c) RAND

d) SRI

21. Which of the following is correct for proximity sensors?

a) Inductive type

b) Capacitive type

c) Ultrasonic wave type

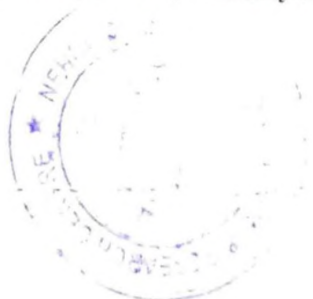

PRINCIPAL  
Nehru College of  
Engineering and Research Centre  
Mangalapuram, Thiruvananthapuram, Kerala  
Pin - 686 597

d) All of the mentioned ✓

**22. Which of the following person used the name robot first time in print?**

a) Josef capek

b) Karel capek

c) Isaac asimov ✓

d) None of the mentioned

**23. Principles of cybernetics was developed by \_\_\_\_\_**

a) Josef capek

b) Norbert wiener

c) Isaac asimov ✓

d) Karel capek

**24. Which of the following represents muscles of a robot?**

a) Actuators

b) Power supply ✓

c) Micro controllers

d) Robotic arm

**25. ZMP stands for \_\_\_\_\_**

a) Zero movement power

b) Zero magnetic point

c) Zero moment point ✓

d) Zero metric point



*Ch*

**PRINCIPAL**

Nehru College of  
Engineering and Research Centre  
Thiruvananthapuram, Thiruvananthapuram  
Kerala



NEHRU COLLEGE OF ENGINEERING AND RESEARCH CENTRE  
(NAAC Accredited)



DEPARTMENT OF MECHANICAL ENGINEERING

END COURSE EXAMINATION

Course: **ADVANCES IN ROBOTICS**

Date: September 19, 2015

Academic Year: **2015-16**

Total Marks: **50**

Total Duration: **1 hour**

38/50

- Put a tick towards the right answer.
- If multiple options are chosen for a question it will not be considered for evaluation.
- Attend all the questions.
- There will be no negative marking.

Name: Vishnuvaj. G.S

Register Number: NCADME132

Semester/Year: 7th / 2th

Each question carries 2 marks

1. What is the name for information sent from robot sensors to robot controllers?

- a) temperature
- b) pressure
- c) feedback ✓
- d) signal

2. Which of the following terms refers to the rotational motion of a robot arm?

- a) swivel
- b) axle
- c) retrograde
- d) roll ✓

3. What is the name for space inside which a robot unit operates?

- a) environment
- b) spatial base
- c) work envelope ✓
- d) exclusion zone



*(Handwritten signature)*

PRINCIPAL  
Nehru College of  
Engineering and Research Centre  
Pampady, Thiruvananthapuram  
Phone: 94472 22117

4. Which of the following terms IS NOT one of the five basic parts of a robot?

- a) peripheral tools
- b) end effectors
- c) controller
- d) drive

5. Decision support programs are designed to help managers make \_\_\_\_\_

- a) budget projections
- b) visual presentations
- c) business decisions
- d) vacation schedules

6. PROLOG is an AI programming language which solves problems with a form of symbolic logic known as predicate calculus. It was developed in 1972 at the University of Marseilles by a team of specialists. Can you name the person who headed this team?

- a) Alain Colmerauer
- b) Niklaus Wirth
- c) Seymour Papert
- d) John McCarthy

7. The number of moveable joints in the base, the arm, and the end effectors of the robot determines \_\_\_\_\_

- a) degrees of freedom
- b) payload capacity
- c) operational limits
- d) flexibility

8. Which of the following places would be LEAST likely to include operational robots?

- a) warehouse
- b) factory
- c) hospitals
- d) private homes

9. For a robot unit to be considered a functional industrial robot, typically, how many degrees of freedom would the robot have?

- a) three
- b) four
- c) six
- d) eight

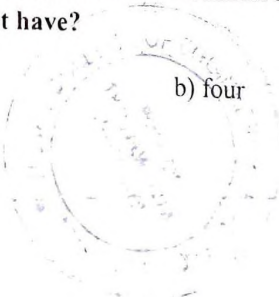

10. Which of the basic parts of a robot unit would include the computer circuitry that could be programmed to determine what the robot would do?

- a) sensor
- b) controller
- c) arm
- d) end effector

11. Which of the following terms refers to the use of compressed gasses to drive (power) the robot device?

- a) pneumatic
- b) hydraulic
- c) piezoelectric
- d) photosensitive



12. With regard to the physics of power systems used operate robots, which statement or statements are most correct?

- a) hydraulics involves the compression of liquids
- b) hydraulics involves the compression of air
- c) pneumatics involve the compression of air
- d) chemical batteries produce AC power

13. The original LISP machines produced by both LMI and Symbolics were based on research performed at

- a) CMU
- b) MIT
- c) Stanford University
- d) RAMD





14. Which of the following statements concerning the implementation of robotic systems is correct?

- a) implementation of robots CAN save existing jobs
- b) implementation of robots CAN create new jobs
- c) robotics could prevent a business from closing
- d) all of the mentioned

15. Which of the following IS NOT one of the advantages associated with a robotics implementation program?

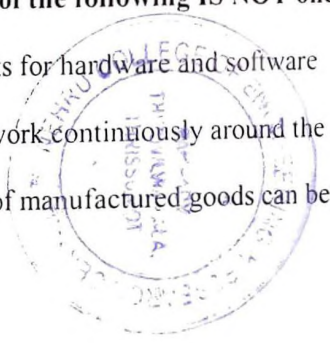
- a) Low costs for hardware and software
- b) Robots work continuously around the clock
- c) Quality of manufactured goods can be improved



  
 PRINCIPAL  
 Nehru College of  
 Engineering and Research Centre  
 Thursday, 10/11/2016 10:50 AM  
 P. 10/11/2016 10:50 AM

d) Reduced company cost for worker fringe benefits

**16. Which of the following "laws" is Asimov's first and most important law of robotics?**

- a) robot actions must never result in damage to the robot
- b) robots must never take actions harmful to humans
- c) robots must follow the directions given by humans
- d) robots must make business a greater profit

**17. In LISP, the function returns t if <object> is a CONS cell and nil otherwise \_\_\_\_\_**

- a) (cons <object>)
- b) (consp <object>)
- c) (eq <object>)
- d) (conu = <object>)

**18. In a rule-based system, procedural domain knowledge is in the form of \_\_\_\_\_**

- a) production rules
- b) rule interpreters
- c) meta-rules
- d) control rules

**19. If a robot can alter its own trajectory in response to external conditions, it is considered to be \_\_\_\_\_**

- a) intelligent
- b) mobile
- c) open loop
- d) non-servo

**20. One of the leading American robotics centers is the Robotics Institute located at?**

- a) CMU
- b) MIT
- c) RAND
- d) SRI

**21. Which of the following is correct for proximity sensors?**

- a) Inductive type
- b) Capacitive type
- c) Ultrasonic wave type

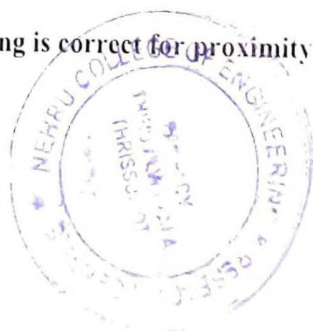

  
 PRINCIPAL  
 NERU College of  
 Engineering and Research Centre  
 Hyderabad, India

d) All of the mentioned

**22. Which of the following person used the name robot first time in print?**

a) Josef capek

b) Karel capek

c) Isaac asimov

d) None of the mentioned

**23. Principles of cybernetics was developed by \_\_\_\_\_**

a) Josef capek

b) Norbert wiener

c) Isaac asimov

d) Karel capek

**24. Which of the following represents muscles of a robot?**

a) Actuators

b) Power supply

c) Micro controllers

d) Robotic arm



**25. ZMP stands for \_\_\_\_\_**

a) Zero movement power

b) Zero magnetic point

c) Zero moment point

d) Zero metric point



PRINCIPAL

Netaji College of

Engineering and Technology

**NEHRU COLLEGE OF ENGINEERING AND RESEARCH CENTRE, PAMPADY, THRISSUR**

**DEPARTMENT OF MECHANICAL ENGINEERING  
END COURSE EXAM MARK STATEMENT**

YEAR: 2015-16  
COURSE: ADVANCES IN ROBOTICS  
FACULTY-IN-CHARGE: Mr.RIXON K L

Sl. No	Reg No	Name	MARKS (50)
1	NCAMEME001	ABDUL HASHIM V.S	34
2	NCAMEME004	ABHIJIT RAVI	30
3	NCAMEME002	ABHIJITH B	42
4	NCAMEME003	ABHIJITH K.U	42
5	NCAMEME005	ABHILASH A	44
6	NCAMEME006	ABHIMALECK GEORGE M	38
7	NCAMEME138	ABHINAV KRISHNAN	34
8	NCAMEME007	ABIN VARGHESE V.P	28
9	NCAMEME139	ABU BACKER A	48
10	NCAMEME008	ACHUTH P	38
11	NCAMEME009	ADARSH M	34
12	NCAMEME010	ADARSH MURALI MENON	42
13	NCAMEME011	AFFEEZ P.M	42
14	NCAMEME012	AFSHAD OMBAN	14
15	NCAMEME013	AKHIL C.K	20
16	NCAMEME014	AKHIL C.S	34
17	NCAMEME017	AKHIL PRASAD	28
18	NCAMEME016	AKHILESH R	48
19	NCAMEME019	AKSHAY M	38
20	NCAMEME020	AKSHAY PRASAD H	34
21	NCAMEME022	ALEN M.A	42
22	NCAMEME143	AMAL DEV B	42
23	NCAMEME024	AMITH S	44
24	NCAMEME025	ANAND KOYILI	38
25	NCAMEME026	ANANTHA PADMANABHAN C.D	34
26	NCAMEME027	ANANTHA VISHNU M.H	38
27	NCAMEME140	ANFAR I	34
28	NCAMEME028	ANIRUDH K	42
29	NCAMEME029	ANOOP K.V	42
30	NCAMEME141	ANOOP P.B	28
31	NCAMEME030	ANURAG K.B	34
32	NCAMEME031	ANVAR SADATH P	32
33	NCAMEME032	ARAVIND M.R	34
34	NCAMEME033	ARAVIND PR	30
35	NCAMEME034	ARJUN A	36
36	NCAMEME035	ARJUN ARAVINDAKSHAN	36
37	NCAMEME036	ARJUN DIVAKARAN K	32
38	NCAMEME037	ARJUN K.S	26
39	NCAMEME038	ARON ANTONY	40
40	NCAMEME039	ARUN C ANTONY	16
41	NCAMEME040	ARUN TITUS	14
42	NCAMEME041	ASHIQUE P.T	42
43	NCAMEME043	ASWIN R	28
44	NCAMEME044	BASIL EBRAHIM	28
45	NCAMEME045	BHARATH.K.B.	36
46	NCAMEME046	BIPINDAS K.K	40
47	NCAMEME144	BRITTO CHERUVATHUR T	32
48	NCAMEME047	DHEERAJ K	36
49	NCAMEME145	GOKUL DAS K.S	42
50	NCAMEME051	HARIDASAN K.P	44
51	NCAMEME052	HARIKRISHNAN U.	42
52	NCAMEME054	HARILAL N	38
53	NCAMEME055	HAROON AL HADI S.K	20
54	NCAMEME057	JAMSHIEER P	44
55	NCAMEME058	JAYADEV K	34
56	NCAMEME060	JUNAID K.P	38
57	NCAMEME061	JUNU FASIN	42
58	NCAMEME062	KARNAN P RAYAROTH	42
59	NCAMEME063	KUNJU MUHAMMED KY	44
60	NCAMEME064	MATHEW KOSHY	20
61	NCAMEME065	MEHROOF EBRAYI	44
62	NCAMEME066	MIDHUN BALACHANDRAN	38

Sl. No	Reg No	Name	MARKS (50)
63	NCAMEME068	MIJITH C	42
64	NCAMEME069	MITHIL R	38
65	NCAMEME072	MOHAMED SUAIB	26
66	NCAMEME073	MOHAMMED AJMAL C	26
67	NCAMEME074	MOHAMMED LABEEB T.K	26
68	NCAMEME070	MOHAMMED SHABEEBUDHEEN	12
69	NCAMEME075	MOHAMMED SHEBIN K.B	32
70	NCAMEME076	MUHAMMED ANZARI T	38
71	NCAMEME077	MUHAMMED ASHIK	34
72	NCAMEME078	MUHAMMED JASEER K.P.P	38
73	NCAMEME079	MUHAMMED SHAREEF V	34
74	NCAMEME081	NAIR JISHNU RAMACHANDRAN	42
75	NCAMEME082	NAVEEN R	42
76	NCAMEME083	NAVEEN ROSH V	26
77	NCAMEME086	NOEL THOMAS	34
78	NCAMEME087	PRABHIJITH P	48
79	NCAMEME088	PRAJITH K.S	36
80	NCAMEME091	PRANAV P.S	48
81	NCAMEME089	PRASHANTH PREMRAJ MENON	46
82	NCAMEME090	PREJIN P	34
83	NCAMEME092	RAJESH R	36
84	NCAMEME094	RENJITH C	30
85	NCAMEME095	RENJITH MENON V.P	28
86	NCAMEME096	ROHITH R UNNI	32
87	NCAMEME098	SAJEEV C.V	36
88	NCAMEME099	SALIM JAHANGEER	26
89	NCAMEME101	SANIL SANKER A	28
90	NCAMEME102	SANJAY K.S	42
91	NCAMEME103	SANJEER K	26
92	NCAMEME104	SARATH K	32
93	NCAMEME106	SARATH P.R	32
94	NCAMEME107	SHIHABUDHEEN.M.A	38
95	NCAMEME108	SIBI VIVIEK K.P	34
96	NCAMEME110	SOORAJ R NAIR	38
97	NCAMEME116	SREE VALLAB M	34
98	NCAMEME112	SREEJITH S	42
99	NCAMEME113	SREENATH NU	34
100	NCAMEME114	SREERAJ P	32
101	NCAMEME117	SUDEV K.V	36
102	NCAMEME118	SUDHARSAN KRISHNAN	36
103	NCAMEME146	SUDHEEP KUMAR K.M	36
104	NCAMEME119	SUDHEEP P	32
105	NCAMEME120	SURAJ R PAI	26
106	NCAMEME121	SWAROOP A	34
107	NCAMEME122	SWATIN RAJ VR	32
108	NCAMEME123	THOMAS C DELSON	32
109	NCAMEME124	TONY JOSE	38
110	NCAMEME147	TONY TOM	28
111	NCAMEME125	VINISH VIJAYAN PILLAI	12
112	NCAMEME126	VIPIN K	36
113	NCAMEME136	VISAK.V.M.	30
114	NCAMEME127	VISHNU C	42
115	NCAMEME128	VISHNU C BALAN NAIR	44
116	NCAMEME129	VISHNU K	26
117	NCAMEME130	VISHNU K.H	28
118	NCAMEME133	VISHNU RAJ.P	36
119	NCAMEME134	VISHNU SREEKUMAR	34
120	NCAMEME131	VISHNULAL N.S	26
121	NCAMEME132	VISHNURAJ G.S	38
122	NCAMEME135	VIVEK S PRASAD	38
123	NCAMEME137	YADHUKRISHNAN T.M	26

  
**PRINCIPAL**  
 Nehru College of  
 Engineering and Research Centre  
 Pampady, Thiruvananthapuram, Thiruvananthapuram Dt  
 48, 897 Ayrath  
**FACULTY-IN-CHARGE**



# Certificate



**VISHNURAJ G.S**

had successfully completed **ADVANCES IN ROBOTICS**  
during 2015-2016 conducted by **Department of Mechanical  
Engineering** at, Nehru College of Engineering and Research  
Centre Pampady, Thrissur.

**PROGRAM  
CO-ORDINATOR**

**HEAD OF  
DEPARTMENT**

**PRINCIPAL**  
Nehru College of  
Engineering and Research Centre  
Pampady, Thrissur





# Certificate



**ABDUL HASHIM V.S**

had successfully completed **ADVANCES IN ROBOTICS**  
during 2015-2016 conducted by **Department of Mechanical  
Engineering** at, Nehru College of Engineering and Research  
Centre Pampady, Thrissur.

PROGRAM  
CO-ORDINATOR

HEAD OF  
DEPARTMENT

PRINCIPAL  
Nehru College of  
Engineering and Research Centre

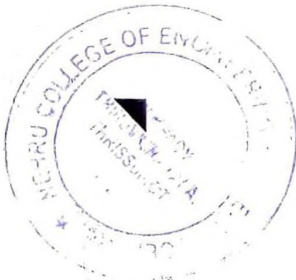



# Certificate



**JAMSHEER P**

had successfully completed **ADVANCES IN ROBOTICS**  
during 2015-2016 conducted by **Department of Mechanical  
Engineering** at, Nehru College of Engineering and Research  
Centre Pampady, Thrissur.

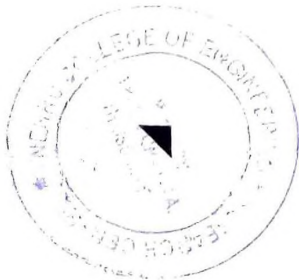

PROGRAM  
CO-ORDINATOR

HEAD OF  
DEPARTMENT

PRINCIPAL  
Nehru College of  
Engineering and Research Centre  
Pampady, Thrissur



# **NEHRU COLLEGE OF ENGINEERING AND RESEARCH CENTRE**



*(NAAC Accredited)  
(Approved by AICTE & Affiliated to University of Calicut  
and Kerala Technological University)*

## **DEPARTMENT OF MECHANICAL ENGINEERING**

The Department of Mechanical Engineering is planning to conduct a 30 hour certification course scheduled during the months of August and September of this academic year 2015 - 2016. The course is intended to be beneficial for students in their academics as well as professional life and therefore is offered to all B.Tech Mechanical Engineering students. All the students are here by directed to enroll in the course mandatorily.

**COURSE NAME: "ADVANCES IN ROBOTICS"**

**PROGRAM CO-ORDINATOR: Mr. RIXON K L**  
Assistant Professor  
Mechanical Department

**DATE OF COMMENCEMENT: 10th August 2015**

**DURATION: 30 Hours**



  
**PRINCIPAL**  
Nehru College of  
Engineering and Research Centre  
Panipady, Thiruvananthapuram, Pin 680 457 Kerala

DEPARTMENT OF MECHANICAL ENGINEERING, NCERC, PAMPADY

(NAAC Accredited)

DEPARTMENT ADVISORY COMMITTEE MEETING MINUTES

Venue: Mechanical HoD Room





Date: 15/07/2015

Time: 12.10 pm

Agenda:

- Introduction of certificate courses for the Academic Year 2015-16
- Any other matter

Members Present

- Prof. G Suresh, HOD 
- Prof. KB Javvarre Gowda, Professor 
- Dr.S Sankar, Asst. Professor 
- Mr. Sanoj T, Asst. Professor 
- Mr. Rixon K L, Asst. Professor 

Minutes of the meeting:

- HoD welcomed the members of Department advisory committee to the meeting.
- It was decided to conduct three certificate courses of 30 hour duration with an end course exam for all interested UG students in ME Dept.
- The course names and faculties handling the courses are decided to be:
  1. **ADVANCES IN ROBOTICS- Mr. Rixon K L**
  2. **ENTERPRISE RESOURCE PLANNING- Mr. Sanoj T**
  3. **CNC MAHINES, CONTROLS AND PART PROGRAMMING- Mr. Prashob M A**
- It was decided that the course 1 and 2 to be taken in Odd semester and course 3 to be taken in even semester of 2015-16 Academic Year.
- HoD instructed the faculties to fix the dates of commencement and get the permission from principal.

Meeting came to an end at 12.30pm.

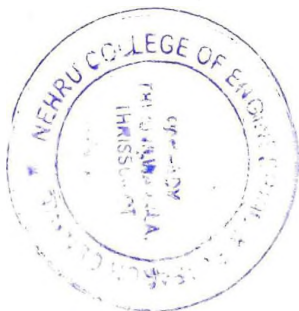

  
PRINCIPAL  
Nehru College of  
Engineering and Research Centre  
Pampady, Thiruviththala, Thiruvananthapuram Dt.  
Pin - 690 601, Kerala

From,

**Mr. Sanoj T**

Assistant Professor

Department Of Mechanical Engineering

Nehru College of Engineering and Research Centre

Pampady, Thrissur

To,

**The Principal**

Nehru College of Engineering and Research Centre

Pampady, Thrissur

Through HoD

Respected Sir,

**Sub: Permission to conduct certification courses during the academic year 2015-16-reg**

The Department of Mechanical Engineering is planning to conduct a 30 hour certification course on “**ENTERPRISE RESOURCE PLANNING: AN OVERVIEW**”, scheduled during the months of August and September of this academic year 2015-16. The course is intended to be beneficial for students in their academics as well as professional life and therefore is offered to all B.Tech Mechanical Engineering students from 11/08/2015 onwards.

I humbly request you to kindly grant the permission for the same.



Thanking You

Place: Pampady

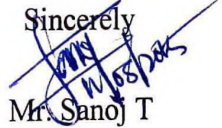
Date: 11/08/2015

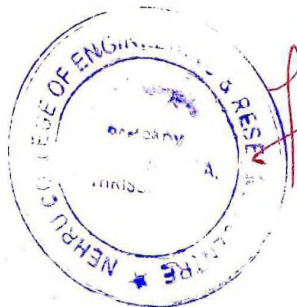
Sincerely  
  
Mr. Sanoj T



*Forwarded to Principal*  
  
11/08/15  

  
**PRINCIPAL**  
Nehru College of  
Engineering and Research Centre  
Pampady, Thiruvithamala, Thrissur Dt  
Pin: 686 597 Kerala



**NEHRU COLLEGE OF ENGINEERING AND RESEARCH  
CENTRE**

**(NAAC Accredited)**



Since 1968

(Approved by AICTE & Affiliated to University of Calicut and Kerala Technological University)

**DEPARTMENT OF MECHANICAL ENGINEERING**

**CIRCULAR**

**Date: 03/08/2015**

The Department of Mechanical Engineering is planning to conduct a 30 hour certification course on **“ENTERPRISE RESOURCE PLANNING: AN OVERVIEW”**, scheduled during the months of August and September of this academic year 2015-16. The course is intended to be beneficial for students in their academics as 11<sup>th</sup> August 2015 onwards. All interested students are hereby directed to enroll in the course .

HoD,

*[Handwritten signature]*  
03/08/15

Department of Mechanical Engineering

Copy to,

Department Notice Board

To be read in all classes



*[Handwritten signature]*

**PRINCIPAL**  
Nehru College of  
Engineering and Research Centre  
Pampady, Thiruvananthapuram, Thiruvananthapuram  
Dist. - 695 020 Kerala



NEHRU COLLEGE OF ENGINEERING AND RESEARCH CENTRE  
(NAAC Accredited, Affiliated to University of Calicut, Kerala Technological  
University)



DEPARTMENT OF MECHANICAL ENGINEERING

**ENTERPRISE RESOURCE PLANNING**

**Year: 2015-16**

**Duration: 30 Hours**

**Pre-requisites:**

Basic idea about enterprise activities

**Course Objectives:**

- To provide awareness about the ERP concepts and the technologies that bridges gap between business associates and customers.
- To emphasize the fitting requirements of ERP packages in different industrial domains.
- To understand how companies have implemented ERP successfully.

To give the Student:-

- A foundation in the fundamentals of Enterprise Resource Planning;
- Design and implement the various ERP modules as per the requirements of the clients;
- An introduction to cloud ERP;

**Syllabus**

**Module 1**

Enterprise Resource Planning: Business modelling; Integrated data model, Introduction to ERP: Defining ERP, Origin and Need for an ERP System, Benefits of an ERP System, Reasons for the Growth of ERP Market, Reasons for the Failure of ERP Implementation: Roadmap for successful ERP implementation,

ERP and Related Technologies: Business Process Re-engineering, Management Information systems, Decision Support Systems, Executive Information Systems- Advantages of EIS; Disadvantages of EIS, Data Warehousing, Data Mining, On-Line Analytical Processing, Product Life Cycle Management, Supply Chain Management, ERP Security

**Module 2**

ERP Implementation Life Cycle: ERP Tools and Software, ERP Selection Methods and Criteria, ERP Selection Process, ERP Vendor Selection, ERP Implementation Lifecycle, Pros and cons of ERP implementation. Factors for the Success of an ERP Implementation

ERP Modules Structure: Finance, Sales and Distribution, Manufacturing and Production Planning- Material and Capacity Planning; Shop Floor Control; Quality Management; JIT/Repetitive Manufacturing; Cost Management ; Engineering Data Management; Engineering Change Control; Tooling, Human Resource, Plant Maintenance- Preventive Maintenance Control; Equipment Tracking; Component Tracking; Plant Maintenance Calibration Tracking; Plant Maintenance Warranty Claims

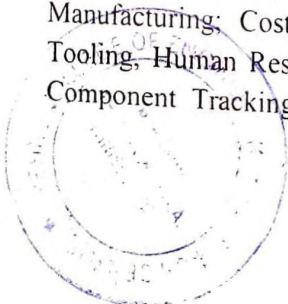

**PRINCIPAL**  
Neeru College of  
Engineering and Research Centre  
Campus: 1076, Kumbalangi, Kumbalangi Dt.  
Pin: 686 567 Kerala

Tracking, Purchasing; Vendor Evaluation; Inventory Management and Invoice Verification and Material Inspection

### Module 3

ERP – A Manufacturing Perspective: Role of Enterprise Resource Planning (ERP) in manufacturing, Computer Aided Design/Computer Aided Manufacturing (CAD/CAM), Materials Requirement Planning (MRP)-Master Production Schedule (MPS);Bill of Material (BOM); Inventory Records; Closed Loop MRP; Manufacturing Resource Planning (MRP-II),

### Module 4

Manufacturing and Production Planning Module of an ERP System , Distribution Requirements Planning (DRP). Just-in-Time(JIT) & KANBAN - Kanban; Benefits of JIT; Potential Pitfalls of JIT; Kanban. Product Data Management (PDM)- Data Management, Process Management; functions of PDM; Benefits of PDM, Manufacturing Operations- Make-to-Order (MTO) and Make-to-Stock (MTS); Assemble-to-Order (ATO); Engineer-to-Order (ETO); Configure-to-Order (CTO)

### Module 5

ERP: A Purchasing Perspective: Role of ERP in Purchasing, Purchase Module: Features of purchase module; Benefits of purchase module, ERP Purchase System

ERP: An Inventory Management Perspective: Role of ERP in Inventory Management: Features of ERP inventory management system; Benefits of ERP inventory management system; Limitations of ERP inventory management system, Importance of Web ERP in Inventory Management, ERP Inventory Management Module, Sub-Modules of the ERP Inventory Management Module, Installation of ERP Inventory Management System, and Failure of ERP Inventory Installation

### Course Outcome:

Students who successfully complete this course will have demonstrated an ability to understand the fundamental concepts of enterprise resource planning. Apply the basic knowledge of the subject to design various modules as well as an integrated ERP system for an enterprise. The specific module includes materials module, Human resource module, financial modules etc, to name a few.

### Text Books:

1. Rajesh Ray "Enterprise Resource Planning", Tata McGraw Hill Education Private Limited, New Delhi.
2. Vinod Kumar Garg and Venkitakrishnan N K. "Enterprise Resource Planning-Concepts and Practice". PHI, 2006
3. David L. Olson, "Managerial issues of Enterprise Resource Planning systems" TMH Edition 2008.

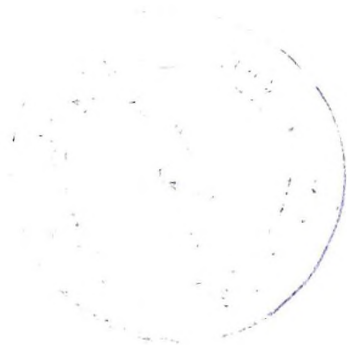

  
PRINCIPAL  
H. P. S. ...  
Engineering and Technology Centre  
...

**NEHRU COLLEGE OF ENGINEERING AND RESEARCH CENTRE**  
(NAAC Accredited, Affiliated to University of Calicut, Kerala Technological University)

**DEPARTMENT OF MECHANICAL ENGINEERING**  
**ENTERPRISE RESOURCE PANNING: AN OVERVIEW**

**LECTURE PLAN**

**TOPICS**

**DATE**

**MODULE 1**

ERP, Integrated model, business model	11/08/2015
ERP origin, need, reason for failure of ERP implementaion, success of Implementation	13/08/2015
Business process reengineering, MIS, Decision support system	17/08/2015
Product life cycle management, supply chain management, ERP Security	20-08-2015

**MODULE 2**

ERP tools & software, Selection method and criteria	22-08-2015
ERP Vendor selection, ERP implementation, factors of ERP Implementation	24-08-2015
ERP Model structure, JIT, cost management, Shop floor control	26-08-2015
Engineering data management, Plant maintainance management	31-08-2015

**MODULE 3**

Role of ERP on manufacturing, CAD/ CAM	02/09/2015
mechanical grippers, tool as end effectors, end effector interface	04/09/2015
Material resource planning, MPS	08/09/2015
Bill Of Material, Inventory record, Closed loop MRP, MRP II	10/09/2015

**MODULE 4**

Manufacturing and Production Planning Module of an ERP System , Distribution Requirements Planning (DRP)	12/09/2015
Just-in-Time(JIT) & KANBAN - Kanban; Benefits of JIT; Potential Pitfalls of JIT; Kanban,	12/09/2015
Product Data Management (PDM)- Data Management, Process Management; functions of PDM; Benefits of PDM,	14/09/2015
Manufacturing Operations- Make-to-Order (MTO) and Make-to-Stock (MTS); Assemble-to-Order (ATO); Engineer-to-Order (ETO); Configure-to-Order (CTO)	16/09/2015

**MODULE 5**

Manufacturing and production planning of an ERP system	19/09/2015
Purchase module, Features of purchase module, benefits of module	19-09-2015
Role, features, benefits, limitations of ERP on inventory management system	22/09/2015
Modules of ERP, Submodules of ERP, ERP installation failure	24/09/2015
<b>End course examination</b>	25/09/2015



*Handwritten signature*

**PRINCIPAL**  
Nehru College of  
Engineering and Research Centre  
Pampady, Thrissur  
Pin - 680 597 Kerala

**NEHRU COLLEGE OF ENGINEERING AND RESEARCH CENTRE, PAMPADY, THRISSUR**  
**DEPARTMENT OF MECHANICAL ENGINEERING**

**ENROLLMENT LIST**

**COURSE NAME: ENTERPRISE RESOURCE PLANNING: AN OVERVIEW**

**ACADEMIC YEAR: 2015-16**

**PROGRAM COORDINATOR: Mr.SANOJ T**

SL.NO	REG NO	NAME	SL.NO	REG NO	NAME
1	NCANEME001	AABIND KRISHNA K	71	NCANEME132	KIRAN P S
2	NCANEME002	ABDUL RASHID P A	72	NCANEME069	MANEESH M NAIR
3	NCANEME003	ABHAI DEV AMBOOKEN	73	NCANEME070	MIDHUN REJI M
4	NCANEME004	ABIJITH G	74	NCANEME071	MIDHUN S NARAYANAN
5	NCANEME128	ABIJITH U	75	NCANEME072	MOHAMAD JASEEL K
6	NCANEME005	ADHITH SIVADAS	76	NCANEME073	MOHAMMED NIZAM C
7	NCANEME006	ADHVAITH G	77	NCANEME074	MUHAMMED ASHIQUE A.K
8	NCANEME007	ADITH NAIR	78	NCANEME075	MUHAMMED FAZIL K M
9	NCANEME008	ADWAITH KT	79	NCANEME076	NAZIM K SHAJAHAN
10	NCANEME009	AJAY P U	80	NCANEME077	NIDESH NELLANI
11	NCANEME010	AJIL ABRAHAM	81	NCANEME078	NIHAS M H
12	NCANEME011	AJO ABRAHAM	82	NCANEME079	NISAR AHAMMED P
13	NCANEME012	AKHIL A.M	83	NCANEME080	NITHIN MENON
14	NCANEME013	AKHIL T	84	NCANEME081	NITHIN MOHAN
15	NCANEME014	AKHIL V	85	NCANEME082	NITHIN V
16	NCANEME015	AKSHAI K.B	86	NCANEME083	PRANAV K J
17	NCANEME016	AKSHAY ARAVIND A	87	NCANEME084	PRAVEEN D
18	NCANEME017	AKSHAY KUMAR B	88	NCANEME085	RAHUL G SATHYAN
19	NCANEME019	AMIRSUHAIL P.V	89	NCANEME086	RAKESH K
20	NCANEME020	ANAND K.V	90	NCANEME087	RAKESH KRISHNA
21	NCANEME021	ANANTHAKRISHNAN NAIR A	91	NCANEME088	RAMESH K K
22	NCANEME022	ANIRUDH T J	92	NCANEME089	RANJITH P D
23	NCANEME023	ANISH N	93	NCANEME139	RASHID MUHINUDHEEN
24	NCANEME024	ANOOP K	94	NCANEME090	REVANTH R
25	NCANEME026	ANOOP RAJ A	95	NCANEME091	RICHARD JOHNSON
26	NCANEME025	ANOOPKUMAR K	96	NCANEME092	RITHIN K RAJAN
27	NCANEME027	ARJUN K	97	NCANEME093	ROBBY K R
28	NCANEME029	ARJUN M	98	NCANEME094	RUPESH G
29	NCANEME030	ARUN S	99	NCANEME140	SABARISH CHANDRAN
30	NCANEME031	ASHOK KALYAN P.M	100	NCANEME095	SACHIN PV
31	NCANEME032	ASWIN DAS D	101	NCANEME096	SAIKRISHNA N
32	NCANEME033	ASWIN E	102	NCANEME097	SAJITH T R
33	NCANEME034	ASWIN K K	103	NCANEME141	SAMRAN I T
34	NCANEME035	ASWIN T	104	NCANEME142	SARATHKUMAR N.S
35	NCANEME036	ATHIRA RAJEEVAN	105	NCANEME098	SATHYADEV D
36	NCANEME037	BAIJUMON A.R	106	NCANEME099	SAYOOJ K P
37	NCANEME038	BASIL MARTIN	107	NCANEME100	SHABEER AHAMED
38	NCANEME039	BIJITH MOHAN K	108	NCANEME133	SHAFIN MUHAMAD
39	NCANEME040	C M SREEKANTH	109	NCANEME101	SHAH RUKH HASSAN
40	NCANEME041	C P MUHAMMED FAYAS	110	NCANEME102	SHOBIN KRISHNA P
41	NCANEME042	DANIEL P J	111	NCANEME134	SINU ANTO
42	NCANEME043	DEAN DAVIS A	112	NCANEME103	SOORAJ V
43	NCANEME044	DEEPAK G	113	NCANEME104	SRAVAN K K
44	NCANEME129	DHANIL D	114	NCANEME105	SREEKANTH P R
45	NCANEME045	DHANUSH S PILLAI	115	NCANEME106	SREEKUMAR V NAIR
46	NCANEME046	DHEERAJ K	116	NCANEME107	SREERAG P
47	NCANEME047	DILTON JOY	117	NCANEME108	SREERAG P S
48	NCANEME048	DIXON P JOHNY	118	NCANEME109	SREERAG T V
49	NCANEME130	ELDHOSE K.K	119	NCANEME110	SREERAM C SEKHAR
50	NCANEME049	FAISAL K	120	NCANEME111	SUBINRAJ P S
51	NCANEME137	FAWAZ K	121	NCANEME112	SUHAIB K
52	NCANEME050	GARREN SABU	122	NCANEME113	SURAJ BENNY
53	NCANEME051	GILSON VARGHESE	123	NCANEME114	SWATHY KIRAN
54	NCANEME052	GOKUL PEETHAMBARAN NAIR	124	NCANEME115	SYAM P S
55	NCANEME053	GOUTHAMAN P.R	125	NCANEME116	SYED AJMAL
56	NCANEME054	HAMRAS B H	126	NCANEME136	VAISAK P.V
57	NCANEME131	HAREESH KUMAR P V	127	NCANEME118	VIDYARJUN K.S
58	NCANEME055	HARIKRISHNAN KP	128	NCANEME119	VIGHNESH P C
59	NCANEME138	IMRAN I.T	129	NCANEME120	VINEETH N
60	NCANEME056	JAFFAR MOHAMMED BASHEEK	130	NCANEME121	VISAKH K
61	NCANEME057	JAYASOORYA JAYARAM	131	NCANEME122	VISHNU HARIDAS
62	NCANEME058	JESTIN JOHN	132	NCANEME123	VISHNU MURALI A
63	NCANEME060	JISHNU AJITHKUMAR NAIR	133	NCANEME124	VISHNU R KUMAR
64	NCANEME061	JISINU NARAYANAN	134	NCANEME125	VISHNU R NATH
65	NCANEME062	JITHIN KURIAN JOSEPH			
66	NCANEME063	JITHIN P R			
67	NCANEME064	JOI BOBAN			
68	NCANEME065	JUNAID C			
69	NCANEME066	KARTHIK U			
70	NCANEME067	KIRAN B			

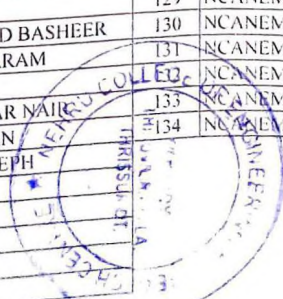

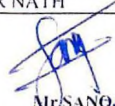
  
**PRINCIPAL**  
 Nehru College of  
 Engineering and Research Centre  
 Pampady, Thrissur  
 PROGRAM COORDINATOR







NEHRU COLLEGE OF ENGINEERING AND RESEARCH CENTRE  
(NAAC Accredited)  
DEPARTMENT OF MECHANICAL ENGINEERING



2015-16 C2

END COURSE EXAMINATION

Course: **ENTERPRISE RESOURCE PLANNING: AN OVERVIEW**

Date: 21/09/2015

Total Marks: **50**

Total Duration: **1 hour**

- Put a tick towards the right answer.
- If multiple options are chosen for a question it will not be considered for evaluation.
- Attend all the questions.
- There will be no negative marking.

Name: \_\_\_\_\_

Register Number: \_\_\_\_\_

Semester/Year: \_\_\_\_\_

*Each question carries 2 marks*

1. \_\_\_\_\_ handling and sharing has become a vital process for efficient and effective working of any organisation.

- a. Material
- b. Resource
- c. Information
- d. Database

2 \_\_\_\_\_ became the fundamental concept of production management and control.

- a. BOM
- b. MRP
- c. ERP
- d. MRP II

3. In the \_\_\_\_\_, ERP packages were targeted at the manufacturing industry.

- a. 1970's
- b. 1990's
- c. 1980's
- d. 1960's

4. The \_\_\_\_\_ should plan well and execute perfectly the implementation of ERP.

- a. Organisation
- b. System developers
- c. Vendors
- d. Top Management

5. Which is one of the most critical steps in the ERP implementation?

- a. Creation of Organisational Model
- b. Creation of Integrated Data Model

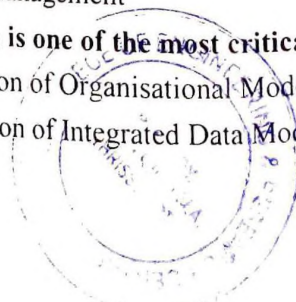

PRINCIPAL  
Nehru College of  
Engineering and Research Centre  
Kannur University, Thiruvananthapuram  
Kerala

- c. Creation of Business Model
- d. Creation of Data Model

**6. What is one of the key resources of every organisation, in today's competitive business environment?**

- a. Employee
- b. Information
- c. ERP
- d. Database

**7. When a customer needs to check the performance of the company before he places an order, which department has to be in a position to provide the necessary information?**

- a. Production
- b. Quality
- c. Marketing
- d. Finance

**8. In an integrated data model, what gives a snapshot of the organisation at any given time?**

- a. ERP
- b. Database
- c. Management
- d. MIS

**9. OLAP stands for:**

- a. On-Line Analytical Processing
- b. On-Line Account Processing
- c. On-Line Arithmetic Processing
- d. On-Line Application Processing

**10. Data mining is the process of identifying valid, new, potentially useful, and ultimately clear \_\_\_\_\_ from databases.**

- a. Decision
- b. Strategies
- c. Information
- d. Account

**11. EIS stands for:**

- a. Executive Interaction System
- b. Executive Interconnecting Systems
- c. Executive Information Systems
- d. Executive Instrumental Systems

**12. DSS is quite \_\_\_\_\_ and is available on request.**

- a. Structured
- b. Non-structured
- c. Semi-structured
- d. Unstructured

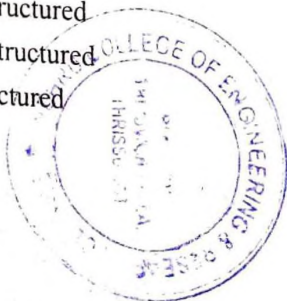

✓

PRINCIPAL  
K. J. Somaiya Institute of Engineering & Information Technology  
Wadgaon, Thane (East)

13. ERP system is built on a \_\_\_\_\_ utilising a common computing platform

- a. Centralised database
- b. Individual databases
- c. Modular databases
- d. Centralised layout

14. Which of the following is an example for commercial ERP

- a. ERP5
- b. Microsoft Dynamics AX
- c. Compiere
- d. Fistera

15. NPV is the abbreviation of

- a. Net Present Variation method
- b. Net Present Value method
- c. Neutral Present Value method
- d. Net Preventive Value method

16. ERP vendors usually design their systems around standard business processes, based upon

- a. Business standards
- b. Global standards
- c. Best business practices.
- d. Best profitable standards

17. The \_\_\_\_\_ module's internal functions do not directly interact with the data or processes of other modules.

- a. Finance
- b. Quality Management
- c. Sales and Distribution
- d. Plant Maintenance

18. Which among the following systems can be assigned to a cost centre directly which illustrates the interface to the cost accounting system?

- a. FAPA
- b. Purchasing
- c. Sales and Distribution
- d. CASO

19. Which system provides the foundation for creating concurrent business processes across the supply chain and achieving Return on Assets (ROA) improvement?

- a. Finance
- b. Inventory
- c. Manufacturing
- d. Sales

20. The processes described in the quality manual can be implemented and automated in the EDP system. Here what does EDP stand for?

- a. Electronic Data Processing

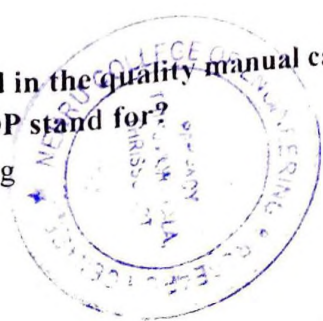

*[Handwritten signature]*  
The Head of the Department  
Engineering College, Anna University  
Chennai - 600 025

- b. Electronic Dictionary Project
- c. Electrical Data Processing
- d. Employee Development Plan

**21. What is the key to MRP?**

- a. Quantity of requirements for components are based upon the structure of the Bill of Material.
- b. Production of requirements for components are based upon the structure of the Bill of Material.
- c. Time-phasing of requirements for components are based upon the structure of the Bill of Material.
- d. Capacity of requirements for components are based upon the structure of the Bill of Material.

**22. During the 80s, tools were developed to assist the planning of:**

- a. Production levels
- b. Priority planning system
- c. Capacity requirements
- d. Planning functions

**23. Complete the sentence: MRP-II systems provide...**

- a. Information that is useful to all functional areas and encourage cross-functional interaction.
- b. Information with cost data.
- c. Information that can be used for other company functions.
- d. Accurate inventory information.

**24. ERP is restricted to being a \_\_\_\_\_ operations system in the country.**

- a. Finance
- b. Budgeting modules
- c. Manufacturing
- d. Transaction-oriented

**25. \_\_\_\_\_ allow companies to enter requirements for various types of items.**

- a. Purchase order
- b. Purchase requisitions
- c. Invoice
- d. General ledger



  
 PRINCIPAL  
 Nehru College of  
 Engineering and Research Centre  
 Thiruvananthapuram, Thiruvananthapuram Dt  
 Pin - 690 597 Kerala

## : ENTERPRISE RESOURCE PLANNING: AN OVERVIEW

### ANSWER KEY

1c, 2b, 3b, 4b, 5b, 6b,  
7c, 8b, 9a, 10c, 11c,  
12d, 13a, 14b, 15c,  
16c, 17b, 18d, 19c,  
20a, 21c, 22a, 23b,  
24d, 25b



A handwritten signature in green ink, consisting of a stylized 'U' followed by a horizontal line.

PRINCIPAL  
Nehru College of  
Engineering and Research Centre  
Pampady, Thiruvananthapuram, Kerala  
Pin - 695 021



NEHRU COLLEGE OF ENGINEERING AND RESEARCH CENTRE  
(NAAC Accredited)  
DEPARTMENT OF MECHANICAL ENGINEERING



END COURSE EXAMINATION

Course: **ENTERPRISE RESOURCE PLANNING: AN OVERVIEW**

Date: 21/09/2015

Total Marks: 50

Total Duration: 1 hour

- Put a tick towards the right answer.
- If multiple options are chosen for a question it will not be considered for evaluation.
- Attend all the questions.
- There will be no negative marking.

42  
50

Name: Eldhose K K

Register Number: NICANEME130

Semester/Year: 4<sup>th</sup> sem / 2nd year

Each question carries 2 marks

1. \_\_\_\_\_ handling and sharing has become a vital process for efficient and effective working of any organisation.
  - a. Material
  - b. Resource
  - c.  Information
  - d. Database
- 2 \_\_\_\_\_ became the fundamental concept of production management and control.
  - a. BOM
  - b.  MRP
  - c. ERP
  - d. MRP II
3. In the \_\_\_\_\_, ERP packages were targeted at the manufacturing industry.
  - a. 1970's
  - b.  1990's
  - c. 1980's
  - d. 1960's
4. The \_\_\_\_\_ should plan well and execute perfectly the implementation of ERP.
  - a.  Organisation
  - b. System developers
  - c. Vendors
  - d. Top Management
5. Which is one of the most critical steps in the ERP implementation?
  - a. Creation of Organisational Model
  - b.  Creation of Integrated Data Model

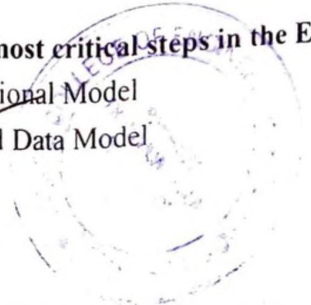

PRINCIPAL  
Nehru College of  
Engineering and Research Centre  
Nampally, Hyderabad-500 075, Tatyasaheb  
M. S. S. K. K.

c. Creation of Business Model

d. Creation of Data Model

6. What is one of the key resources of every organisation, in today's competitive business environment?

a. Employee

b. Information

c. ERP

d. Database

7. When a customer needs to check the performance of the company before he places an order, which department has to be in a position to provide the necessary information?

a. Production

b. Quality

c. Marketing

d. Finance

8. In an integrated data model, what gives a snapshot of the organisation at any given time?

a. ERP

b. Database

c. Management

d. MIS

9. OLAP stands for:

a. On-Line Analytical Processing

b. On-Line Account Processing

c. On-Line Arithmetic Processing

d. On-Line Application Processing

10. Data mining is the process of identifying valid, new, potentially useful, and ultimately clear \_\_\_\_\_ from databases.

a. Decision

b. Strategies

c. Information

d. Account

11. EIS stands for:

a. Executive Interaction System

b. Executive Interconnecting Systems

c. Executive Information Systems

d. Executive Instrumental Systems

12. DSS is quite \_\_\_\_\_ and is available on request.

a. Structured

b. Non-structured

c. Semi-structured

d. Unstructured



PRINCIPAL  
Nehru College of  
Engineering and Research Center  
Thiruvananthapuram

13. ERP system is built on a \_\_\_\_\_ utilising a common computing platform

- a. Centralised database
- b. Individual databases
- c. Modular databases
- d. Centralised layout

14. Which of the following is an example for commercial ERP

- a. ERP5
- b. Microsoft Dynamics AX
- c. Compiere
- d. Fistera

15. NPV is the abbreviation of

- a. Net Present Variation method
- b. Net Present Value method
- c. Neutral Present Value method
- d. Net Preventive Value method

16. ERP vendors usually design their systems around standard business processes, based upon

- a. Business standards
- b. Global standards
- c. Best business practices.
- d. Best profitable standards

17. The \_\_\_\_\_ module's internal functions do not directly interact with the data or processes of other modules.

- a. Finance
- b. Quality Management
- c. Sales and Distribution
- d. Plant Maintenance

18. Which among the following systems can be assigned to a cost centre directly which illustrates the interface to the cost accounting system?

- a. FAPA
- b. Purchasing
- c. Sales and Distribution
- d. CASO

19. Which system provides the foundation for creating concurrent business processes across the supply chain and achieving Return on Assets (ROA) improvement?

- a. Finance
- b. Inventory
- c. Manufacturing
- d. Sales

20. The processes described in the quality manual can be implemented and automated in the EDP system. Here what does EDP stand for?

- a. Electronic Data Processing

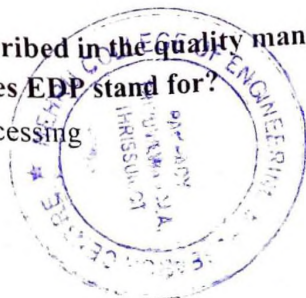

*[Signature]*  
 PRINCIPAL  
 Nehru College of  
 Engineering and Research Centre  
 Anna University, Chennai

- b. Electronic Dictionary Project
- c. Electrical Data Processing
- d. Employee Development Plan

**21. What is the key to MRP?**

- a. Quantity of requirements for components are based upon the structure of the Bill of Material.
- b. Production of requirements for components are based upon the structure of the Bill of Material.
- c. Time-phasing of requirements for components are based upon the structure of the Bill of Material.
- d. Capacity of requirements for components are based upon the structure of the Bill of Material.

**22. During the 80s, tools were developed to assist the planning of:**

- a. Production levels
- b. Priority planning system
- c. Capacity requirements
- d. Planning functions

**23. Complete the sentence: MRP-II systems provide...**

- a. Information that is useful to all functional areas and encourage cross-functional interaction.
- b. Information with cost data.
- c. Information that can be used for other company functions.
- d. Accurate inventory information.

**24. ERP is restricted to being a \_\_\_\_\_ operations system in the country.**

- a. Finance
- b. Budgeting modules
- c. Manufacturing
- d. Transaction-oriented

**25. \_\_\_\_\_ allow companies to enter requirements for various types of items.**

- a. Purchase order
- b. Purchase requisitions
- c. Invoice
- d. General ledger

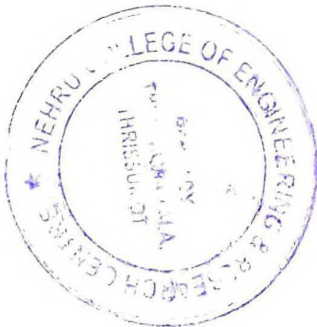

*[Handwritten Signature]*  
**PRINCIPAL**  
 Nehru College of  
 Engineering and Research Centre  
 Mysuru, Channarayana, Mysuru  
 Dist. Channarayana, Karnataka



NEHRU COLLEGE OF ENGINEERING AND RESEARCH CENTRE  
(NAAC Accredited)  
DEPARTMENT OF MECHANICAL ENGINEERING



2015-16 C2

END COURSE EXAMINATION

Course: ENTERPRISE RESOURCE PLANNING: AN OVERVIEW

Date: 21/09/2015

Total Marks: 50

Total Duration: 1 hour

- Put a tick towards the right answer.
- If multiple options are chosen for a question it will not be considered for evaluation.
- Attend all the questions.
- There will be no negative marking.

38  
50

Name: Syama PS

Register Number: NCAANEME15

Semester/Year: Fourth/Second

*Each question carries 2 marks*

1. \_\_\_\_\_ handling and sharing has become a vital process for efficient and effective working of any organisation.

- a. Material
- b. Resource
- c. Information
- d. Database

2. \_\_\_\_\_ became the fundamental concept of production management and control,

- a. BOM
- b. MRP
- c. ERP
- d. MRP II

3. In the \_\_\_\_\_, ERP packages were targeted at the manufacturing industry.

- a. 1970's
- b. 1990's
- c. 1980's
- d. 1960's

4. The \_\_\_\_\_ should plan well and execute perfectly the implementation of ERP.

- a. Organisation
- b. System developers
- c. Vendors
- d. Top Management

5. Which is one of the most critical steps in the ERP implementation?

- a. Creation of Organisational Model
- b. Creation of Integrated Data Model

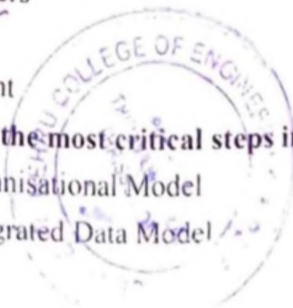

PRINCIPAL  
Nehru College of  
Engineering and Research Centre  
Chennai - 600 074

- c. Creation of Business Model
- d. Creation of Data Model

6. What is one of the key resources of every organisation, in today's competitive business environment?

- a. Employee
- b. Information
- c. ERP
- d. Database

7. When a customer needs to check the performance of the company before he places an order, which department has to be in a position to provide the necessary information?

- a. Production
- b. Quality
- c. Marketing
- d. Finance

8. In an integrated data model, what gives a snapshot of the organisation at any given time?

- a. ERP
- b. Database
- c. Management
- d. MIS

9. OLAP stands for:

- a. On-Line Analytical Processing
- b. On-Line Account Processing
- c. On-Line Arithmetic Processing
- d. On-Line Application Processing

10. Data mining is the process of identifying valid, new, potentially useful, and ultimately clear \_\_\_\_\_ from databases.

- a. Decision
- b. Strategies
- c. Information
- d. Account

11. EIS stands for:

- a. Executive Interaction System
- b. Executive Interconnecting Systems
- c. Executive Information Systems
- d. Executive Instrumental Systems

12. DSS is quite \_\_\_\_\_ and is available on request.

- a. Structured
- b. Non-structured
- c. Semi-structured
- d. Unstructured



PRINCIPAL  
 Nehru College of  
 Engineering and Research Centre  
 Mumbai, Maharashtra

13. ERP system is built on a \_\_\_\_\_ utilising a common computing platform

- a. ~~Centralised database~~
- b. Individual databases
- c. Modular databases
- d. Centralised layout

14. Which of the following is an example for commercial ERP

- a. ERP5
- b. ~~Microsoft Dynamics AX~~
- c. Compiere
- d. Fistera

15. NPV is the abbreviation of

- a. Net Present Variation method
- b. Net Present Value method
- c. ~~Neutral Present Value method~~
- d. Net Preventive Value method

16. ERP vendors usually design their systems around standard business processes, based upon

- a. Business standards
- b. Global standards
- c. ~~Best business practices.~~
- d. Best profitable standards

17. The \_\_\_\_\_ module's internal functions do not directly interact with the data or processes of other modules.

- a. Finance
- b. ~~Quality Management~~
- c. Sales and Distribution
- d. Plant Maintenance

18. Which among the following systems can be assigned to a cost centre directly which illustrates the interface to the cost accounting system?

- a. FAPA
- b. Purchasing
- c. Sales and Distribution
- d. ~~CASO~~

19. Which system provides the foundation for creating concurrent business processes across the supply chain and achieving Return on Assets (ROA) improvement?

- a. Finance
- b. Inventory
- c. ~~Manufacturing~~
- d. Sales

20. The processes described in the quality manual can be implemented and automated in the EDP system. Here what does EDP stand for?

- a. ~~Electronic Data Processing~~

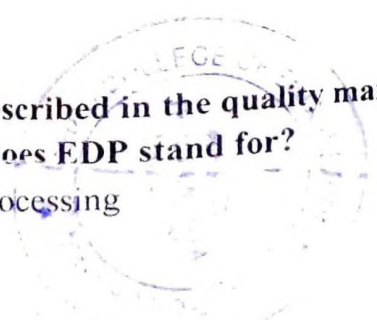

*(Handwritten signature in green ink)*

PRINCIPAL  
Nehru College of  
Engineering and Research Centre  
Palupuzha, Thrissur, Kerala  
Pin - 680 597 Kerala

- b. Electronic Dictionary Project
- c. Electrical Data Processing
- d. Employee Development Plan

**21. What is the key to MRP?**

- a. Quantity of requirements for components are based upon the structure of the Bill of Material.
- b. Production of requirements for components are based upon the structure of the Bill of Material.
- c. Time-phasing of requirements for components are based upon the structure of the Bill of Material.
- d. Capacity of requirements for components are based upon the structure of the Bill of Material.

**22. During the 80s, tools were developed to assist the planning of:**

- a. Production levels
- b. Priority planning system
- c. Capacity requirements
- d. Planning functions

**23. Complete the sentence: MRP-II systems provide...**

- a. Information that is useful to all functional areas and encourage cross-functional interaction.
- b. Information with cost data.
- c. Information that can be used for other company functions.
- d. Accurate inventory information.

**24. ERP is restricted to being a \_\_\_\_\_ operations system in the country.**

- a. Finance
- b. Budgeting modules
- c. Manufacturing
- d. Transaction-oriented

**25. \_\_\_\_\_ allow companies to enter requirements for various types of items.**

- a. Purchase order
- b. Purchase requisitions
- c. Invoice
- d. General ledger



*[Handwritten Signature]*  
 PRINCIPAL  
 Nehru College of  
 Engineering and Research Centre  
 Thiruvananthapuram, Kerala  
 Date: \_\_\_\_\_



NEHRU COLLEGE OF ENGINEERING AND RESEARCH CENTRE  
(NAAC Accredited)  
DEPARTMENT OF MECHANICAL ENGINEERING



END COURSE EXAMINATION  
Course: ENTERPRISE RESOURCE PLANNING: AN OVERVIEW

Date: 21/09/2015

Total Marks: 50

Total Duration: 1 hour

- Put a tick towards the right answer.
- If multiple options are chosen for a question it will not be considered for evaluation.
- Attend all the questions.
- There will be no negative marking.

46  
—  
50

Name: Anand KV

Register Number: NCANEMEO20

Semester/Year: 34/2nd

*Each question carries 2 marks*

1. \_\_\_\_\_ handling and sharing has become a vital process for efficient and effective working of any organisation.

- a. Material
- b. Resource ✓
- c. Information
- d. Database

*(Handwritten mark)*

2. \_\_\_\_\_ became the fundamental concept of production management and control.

- a. BOM
- b. MRP ✓
- c. ERP
- d. MRP II

3. In the \_\_\_\_\_, ERP packages were targeted at the manufacturing industry.

- a. 1970's
- b. 1990's
- c. 1980's
- d. 1960's ✓

*(Handwritten mark)*

4. The \_\_\_\_\_ should plan well and execute perfectly the implementation of ERP.

- a. Organisation
- b. System developers ✓
- c. Vendors
- d. Top Management

5. Which is one of the most critical steps in the ERP implementation?

- a. Creation of Organisational Model
- b. Creation of Integrated Data Model ✓

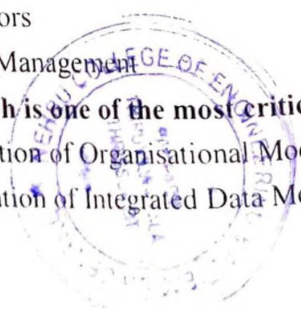

PRINCIPAL  
Neeru College of  
Engineering and Research Centre  
Maddur, Bangalore-560029

c. Creation of Business Model

d. Creation of Data Model

**6. What is one of the key resources of every organisation, in today's competitive business environment?**

a. Employee

b. Information

c. ERP

d. Database

**7. When a customer needs to check the performance of the company before he places an order, which department has to be in a position to provide the necessary information?**

a. Production

b. Quality

c. Marketing

d. Finance

**8. In an integrated data model, what gives a snapshot of the organisation at any given time?**

a. ERP

b. Database

c. Management

d. MIS

**9. OLAP stands for:**

a. On-Line Analytical Processing

b. On-Line Account Processing

c. On-Line Arithmetic Processing

d. On-Line Application Processing

**10. Data mining is the process of identifying valid, new, potentially useful, and ultimately clear \_\_\_\_\_ from databases.**

a. Decision

b. Strategies

c. Information

d. Account

**11. EIS stands for:**

a. Executive Interaction System

b. Executive Interconnecting Systems

c. Executive Information Systems

d. Executive Instrumental Systems

**12. DSS is quite \_\_\_\_\_ and is available on request.**

a. Structured

b. Non-structured

c. Semi-structured

d. Unstructured

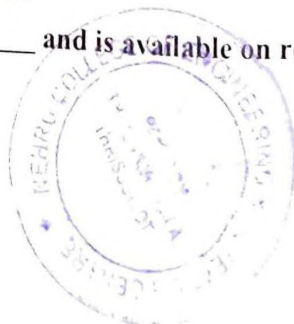

PRINCIPAL  
Nehru College of  
Engineering and Research Centre  
M. V. Road, Mysore - 570 015  
Ph: 0824 24 8124

13. ERP system is built on a \_\_\_\_\_ utilising a common computing platform

- a. Centralised database ✓
- b. Individual databases
- c. Modular databases
- d. Centralised layout

14. Which of the following is an example for commercial ERP

- a. ERPS
- b. Microsoft Dynamics AX ✓
- c. Compiere
- d. Fistera

15. NPV is the abbreviation of

- a. Net Present Variation method
- b. Net Present Value method
- c. Neutral Present Value method ✓
- d. Net Preventive Value method

16. ERP vendors usually design their systems around standard business processes, based upon

- a. Business standards
- b. Global standards
- c. Best business practices. ✓
- d. Best profitable standards

17. The \_\_\_\_\_ module's internal functions do not directly interact with the data or processes of other modules.

- a. Finance
- b. Quality Management ✓
- c. Sales and Distribution
- d. Plant Maintenance

18. Which among the following systems can be assigned to a cost centre directly which illustrates the interface to the cost accounting system?

- a. FAPA
- b. Purchasing
- c. Sales and Distribution
- d. CASQ ✓

19. Which system provides the foundation for creating concurrent business processes across the supply chain and achieving Return on Assets (ROA) improvement?

- a. Finance
- b. Inventory
- c. Manufacturing ✓
- d. Sales

20. The processes described in the quality manual can be implemented and automated in the EDP system. Here what does EDP stand for? ✓

- a. Electronic Data Processing ✓

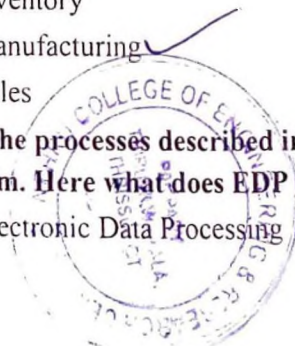

PRINCIPAL  
Nehru College of  
Engineering and Research Centre  
Chennai, Tamil Nadu, India  
Phone: 98404 907 Kerala

- b. Electronic Dictionary Project
- c. Electrical Data Processing
- d. Employee Development Plan

**21. What is the key to MRP?**

- a. Quantity of requirements for components are based upon the structure of the Bill of Material.
- b. Production of requirements for components are based upon the structure of the Bill of Material.
- c. Time-phasing of requirements for components are based upon the structure of the Bill of Material. ✓
- d. Capacity of requirements for components are based upon the structure of the Bill of Material.

**22. During the 80s, tools were developed to assist the planning of:**

- a. Production levels ✓
- b. Priority planning system
- c. Capacity requirements
- d. Planning functions

**23. Complete the sentence: MRP-II systems provide...**

- a. Information that is useful to all functional areas and encourage cross-functional interaction.
- b. Information with cost data. ✓
- c. Information that can be used for other company functions.
- d. Accurate inventory information.

**24. ERP is restricted to being a \_\_\_\_\_ operations system in the country.**

- a. Finance
- b. Budgeting modules
- c. Manufacturing
- d. Transaction-oriented ✓

**25. \_\_\_\_\_ allow companies to enter requirements for various types of items.**

- a. Purchase order
- b. Purchase requisitions ✓
- c. Invoice
- d. General ledger



  
 PRINCIPAL  
 Nellore College of  
 Engineering and Research Centre  
 Thiruvannamalai, Tamil Nadu  
 Pin - 602 015, India

**NEHRU COLLEGE OF ENGINEERING AND RESEARCH CENTRE, PAMPADY, THRISSUR**  
**DEPARTMENT OF MECHANICAL ENGINEERING**  
**END COURSE EXAM MARK STATEMENT**

YEAR: 2015-16  
 COURSE: ENTERPRISE RESOURCE PLANNING: AN OVERVIEW  
 FACULTY-IN-CHARGE: Mr. SANOJ T

Sl. No	Reg No	Name	MARKS (50)
1	NCANEME001	AABIND KRISHNA K	44
2	NCANEME002	ABDUL RASHID P A	36
3	NCANEME003	ABHAI DEV AMBOOKEN	32
4	NCANEME004	ABIJITH G	26
5	NCANEME128	ABIJITH U	42
6	NCANEME005	ADHITH SIVADAS	32
7	NCANEME006	ADHVAITH G	32
8	NCANEME007	ADITH NAIR	42
9	NCANEME008	ADWAITH KT	28
10	NCANEME009	AJAY P U	38
11	NCANEME010	AJIL ABRAHAM	36
12	NCANEME011	AJO ABRAHAM	38
13	NCANEME012	AKHIL A.M	28
14	NCANEME013	AKHIL T	36
15	NCANEME014	AKHIL V	42
16	NCANEME015	AKSHAI K.B	44
17	NCANEME016	AKSHAY ARAVIND A	38
18	NCANEME017	AKSHAY KUMAR B	26
19	NCANEME019	AMIRSUHAIL P.V	34
20	NCANEME020	ANAND K.V	46
21	NCANEME021	ANANTHAKRISHNAN NAIR	28
22	NCANEME022	ANIRUDH T J	42
23	NCANEME023	ANISH N	42
24	NCANEME024	ANOOP K	30
25	NCANEME026	ANOOP RAJ A	38
26	NCANEME025	ANOOPKUMAR K	20
27	NCANEME027	ARJUN K	42
28	NCANEME029	ARJUN M	38
29	NCANEME030	ARUN S	28
30	NCANEME031	ASHOK KALYAN P.M	28
31	NCANEME032	ASWIN DAS D	44
32	NCANEME033	ASWIN E	32
33	NCANEME034	ASWIN K K	28
34	NCANEME035	ASWIN T	28
35	NCANEME036	ATHIRA RAJEEVAN	38
36	NCANEME037	BAIJUMON A.R	38
37	NCANEME038	BASIL MARTIN	34
38	NCANEME039	BIJITH MOHAN K	38
39	NCANEME040	C M SREEKANTH	34
40	NCANEME041	C P MUHAMMED FAYAS	42
41	NCANEME042	DANIEL P J	42
42	NCANEME043	DEAN DAVIS A	10
43	NCANEME044	DEEPAK G	34
44	NCANEME129	DHANIL D	48
45	NCANEME045	DHANUSH S PILLAI	36
46	NCANEME046	DHEERAJ K	48
47	NCANEME047	DILTON JOY	46
48	NCANEME048	DIXON P JOHNY	34
49	NCANEME130	ELDHOSE K.K	42
50	NCANEME049	FAISAL K	30
51	NCANEME137	FAWAZ K	8
52	NCANEME050	GARREN SABU	32
53	NCANEME051	GILSON VARGHESE	36
54	NCANEME052	GOKUL PEETHAMBARAN NAIR	26
55	NCANEME053	GOUTHAMAN P.R	28
56	NCANEME054	HAMRAS B H	42
57	NCANEME131	HAREESH KUMAR P V	26
58	NCANEME055	HARIKRISHNAN KP	32
59	NCANEME138	IMRAN I.T	32
60	NCANEME056	JAFFAR MOHAMMED BASHEER	18
61	NCANEME057	JAYASOORYA JAYARAM	48
62	NCANEME058	JESTIN JOHN	30
63	NCANEME060	JISHNU AJITHKUMAR NAIR	42
64	NCANEME061	JISHNU NARAYANAN	36
65	NCANEME062	JITHIN KURIAN JOSEPH	30
66	NCANEME063	JITHIN P R	36
67	NCANEME064	JOE BOBAN	42

Sl. No	Reg No	Name	MARKS (50)
68	NCANEME065	JUNAID C	42
69	NCANEME066	KARTHIK U	42
70	NCANEME067	KIRAN B	38
71	NCANEME132	KIRAN P S	42
72	NCANEME069	MANEESH M NAIR	44
73	NCANEME070	MIDHUN REJI M	48
74	NCANEME071	MIDHUN S NARAYANAN	12
75	NCANEME072	MOHAMAD JASEEL K	34
76	NCANEME073	MOHAMMED NIZAM C	36
77	NCANEME074	MUHAMMED ASHIQUE A.K	48
78	NCANEME075	MUHAMMED FAZIL K M	38
79	NCANEME076	NAZIM K SHAJAHAN	34
80	NCANEME077	NIDESH NELLANI	36
81	NCANEME078	NIHAS M H	42
82	NCANEME079	NISAR AHAMMED P	26
83	NCANEME080	NITHIN MENON	38
84	NCANEME081	NITHIN MOHAN	34
85	NCANEME082	NITHIN V	26
86	NCANEME083	PRANAV K J	34
87	NCANEME084	PRAVEEN D	28
88	NCANEME085	RAHUL G SATHYAN	34
89	NCANEME086	RAKESH K	32
90	NCANEME087	RAKESH KRISHNA	20
91	NCANEME088	RAMESH K K	36
92	NCANEME089	RANJITH P D	36
93	NCANEME139	RASHID MUHINUDHEEN	32
94	NCANEME090	REVANTH R	26
95	NCANEME091	RICHARD JOHNSON	34
96	NCANEME092	RITHIN K RAJAN	38
97	NCANEME093	ROBBY K R	28
98	NCANEME094	RUPESH G	28
99	NCANEME140	SABARISH CHANDRAN	30
100	NCANEME095	SACHIN PV	48
101	NCANEME096	SAIKRISHNA N	38
102	NCANEME097	SAJITH T R	34
103	NCANEME141	SAMRAN I T	42
104	NCANEME142	SARATHKUMAR N.S	34
105	NCANEME098	SATHYADEV D	30
106	NCANEME099	SAYOOJ K P	30
107	NCANEME100	SHABEER AHAMED	16
108	NCANEME133	SHAFIN MUHAMAD	42
109	NCANEME101	SHAH RUKH HASSAN	42
110	NCANEME102	SHOBIN KRISHNA P	42
111	NCANEME134	SINU ANTO	42
112	NCANEME103	SOORAJ V	38
113	NCANEME104	SRAVAN K K	34
114	NCANEME105	SREEKANTH P R	42
115	NCANEME106	SREEKUMAR V NAIR	42
116	NCANEME107	SREERAG P	36
117	NCANEME108	SREERAG P S	38
118	NCANEME109	SREERAG T V	30
119	NCANEME110	SREERAM C SEKHAR	14
120	NCANEME111	SUBINRAJ P S	42
121	NCANEME112	SUHAIB K	26
122	NCANEME113	SURAJ BENNY	36
123	NCANEME114	SWATHY KIRAN	36
124	NCANEME115	SYAM P S	38
125	NCANEME116	SYED AJMAL	40
126	NCANEME136	VAISAK P.V	48
127	NCANEME118	VIDYARJUN K.S	48
128	NCANEME119	VIGHNESH P C	26
129	NCANEME120	VINEETH N	36
130	NCANEME121	VISAKH K	30
131	NCANEME122	VISHNU HARIDAS	10
132	NCANEME123	VISHNU MURALI A	40
133	NCANEME124	VISHNU R KUMAR	30
134	NCANEME125	VISHNU R NATH	42

PROGRAM COORDINATOR

PRINCIPAL

Nehru College of  
 Engineering and Research Centre  
 Pampady, Talavayal, Thrissur  
 Dist. Palakkad



# Certificate



**SYAM P S**

had successfully completed **ENTERPRISE RESOURCE PLANNING: AN OVERVIEW** during 2015-2016 conducted by **Department of Mechanical Engineering** at, **Nehru College of Engineering and Research Centre Pampady, Thrissur.**

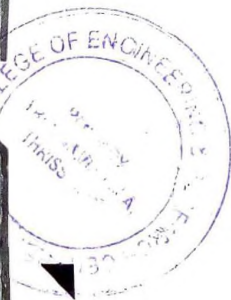

**PROGRAM  
CO-ORDINATOR**

**HEAD OF  
DEPARTMENT**

**PRINCIPAL**  
Nehru College of  
Engineering and Research  
Centre Pampady, Thrissur



# Certificate



**ELDHOSE K.K**

had successfully completed **ENTERPRISE RESOURCE PLANNING: AN OVERVIEW** during 2015-2016 conducted by **Department of Mechanical Engineering** at, **Nehru College of Engineering and Research Centre Pampady, Thrissur.**



**PROGRAM  
CO-ORDINATOR**

**HEAD OF  
DEPARTMENT**

**PRINCIPAL**  
Nehru College of  
Engineering and Research C



# Certificate



**ANAND K.V**

had successfully completed **ENTERPRISE RESOURCE PLANNING: AN OVERVIEW** during 2015-2016 conducted by Department of Mechanical Engineering at, Nehru College of Engineering and Research Centre Pampady, Thrissur.

PROGRAM  
CO-ORDINATOR

HEAD OF  
DEPARTMENT

PRINCIPAL  
Nehru College of  
Engineering and Research Centre  
Pampady, Thrissur

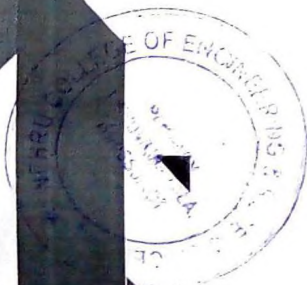



# **NEHRU COLLEGE OF ENGINEERING AND RESEARCH CENTRE**



*(NAAC Accredited)  
(Approved by AICTE & Affiliated to University of Calicut  
and Kerala Technological University)*

## **DEPARTMENT OF MECHANICAL ENGINEERING**

The Department of Mechanical Engineering is planning to conduct a 30 hour certification course scheduled during the months of August and September of this academic year 2015 - 2016. The course is intended to be beneficial for students in their academics as well as professional life and therefore is offered to all B.Tech Mechanical Engineering students. All the students are here by directed to enroll in the course mandatorily.

**COURSE NAME: "ENTERPRISE RESOURCE PLANNING:  
AN OVERVIEW"**

**PROGRAM CO-ORDINATOR: Mr. SANOJ T**

**Assistant Professor**

**Mechanical Department**

**DATE OF COMMENCEMENT: 11th August 2015**

**DURATION: 30 Hours**



**PRINCIPAL**  
Nehru College of  
Engineering and Research Centre  
Pampady, Thiruvilwamala, Thiruvananthapuram Dt  
Pin - 680 597 Kerala

DEPARTMENT OF MECHANICAL ENGINEERING, NCERC, PAMPADY

(NAAC Accredited)

DEPARTMENT ADVISORY COMMITTEE MEETING MINUTES

Venue: Mechanical HoD Room





Date: 15/07/2015

Time: 12.10 pm

Agenda:

- Introduction of certificate courses for the Academic Year 2015-16
- Any other matter

Members Present

- Prof. G Suresh, HOD 
- Prof. KB Javvarre Gowda, Professor 
- Dr.S Sankar, Asst. Professor 
- Mr. Sanoj T, Asst. Professor 
- Mr. Rixon K L, Asst. Professor 

Minutes of the meeting:

- HoD welcomed the members of Department advisory committee to the meeting.
- It was decided to conduct three certificate courses of 30 hour duration with an end course exam for all interested UG students in ME Dept.
- The course names and faculties handling the courses are decided to be:
  1. **ADVANCES IN ROBOTICS- Mr. Rixon K L**
  2. **ENTERPRISE RESOURCE PLANNING- Mr. Sanoj T**
  3. **CNC MAHINES, CONTROLS AND PART PROGRAMMING- Mr. Prashob M A**
- It was decided that the course 1 and 2 to be taken in Odd semester and course 3 to be taken in even semester of 2015-16 Academic Year.
- HoD instructed the faculties to fix the dates of commencement and get the permission from principal.

Meeting came to an end at 12.30pm.

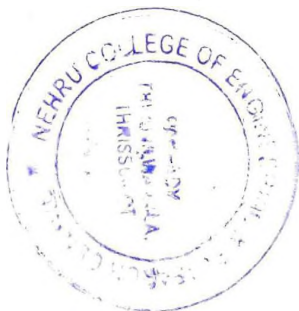

  
PRINCIPAL  
Nehru College of  
Engineering and Research Centre  
Pampady, Thiruviththala, Thiruvananthapuram Dt.  
Pin - 690 601, Kerala

From,

**Mr. Prashob M A**

Assistant Professor

Department Of Mechanical Engineering

Nehru College of Engineering and Research Centre

Pampady, Thrissur

To,

**The Principal**

Nehru College of Engineering and Research Centre

Pampady, Thrissur

Through HoD

Respected Sir,

**Sub: Permission to conduct certification courses during the academic year 2015-16-reg**

The Department of Mechanical Engineering is planning to conduct a 30 hour certification course on "CNC MACHINES, CONTROLS AND PART PROGRAMMING", scheduled during the months of January and February of this academic year 2015-16. The course is intended to be beneficial for students in their academics as well as professional life and therefore is offered to all B.Tech Mechanical Engineering students from 02/02/2016 onwards.

I humbly request you to kindly grant the permission for the same.

Thanking You

Place: Pampady

Date: 27/01/2016

Sincerely

Mr. Prashob MA

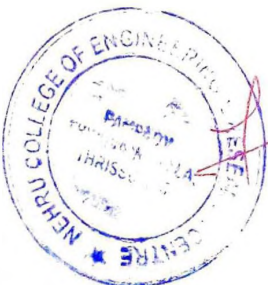

*Forwarded to HoD*  
*CM*  
*27/01/16*

*Forwarded to Principal*  
*28/01*

*Aswath*

*cm*  
PRINCIPAL  
Nehru College of  
Engineering and Research Centre  
Pampady Thiruvilwamala, Thrissur Dt  
Pin 680 597 Kerala



**NEHRU COLLEGE OF ENGINEERING AND RESEARCH  
CENTRE**

**(NAAC Accredited)**



(Approved by AICTE & Affiliated to University of Calicut and Kerala Technological University)

**DEPARTMENT OF MECHANICAL ENGINEERING**

**CIRCULAR**

**Date: 27/01/2016**

The Department of Mechanical Engineering is planning to conduct a 30 hour certification course on “**CNC MACHINES, CONTROLS AND PART PROGRAMMING**”, scheduled during the months of February and March of this academic year 2015-16. The course is intended to be beneficial for students in their academics as well as professional life and therefore is offered to all B.Tech Mechanical Engineering students from 02<sup>nd</sup> February 2016 onwards. All students are hereby directed to enroll in the course mandatorily.

HoD,

*Handwritten signature and date: 27/01/16*

Department of Mechanical Engineering

Copy to,

**Department Notice Board**

**To be read in all classes**



*Handwritten signature in green ink*

**PRINCIPAL**

*Principal, Department of Mechanical Engineering, Nehru College of Engineering and Research Centre*



NEHRU COLLEGE OF ENGINEERING AND RESEARCH CENTRE  
(NAAC Accredited, Affiliated to University of Calicut, Kerala Technological  
University)



## DEPARTMENT OF MECHANICAL ENGINEERING

### CNC MACHINES AND CONTROL

**Year: 2015-16**

**Duration: 30 Hours**

**Pre- requisites:**

Basic knowledge of computer integrated manufacturing

**Course Objectives:**

To understand the construction, working, concepts and controls of Computer Numerical Control machines

**Syllabus:**

**Module 1:**

Concept and scope of industrial automation: Automation strategies, devices, drives and control circuits in automation - Semi-automats, Automats and transfer lines. Mechanical, electrical, hydraulic, pneumatic, electronic & hybrid automation system Comparative evaluation of automation system. Concepts, features, fundamentals, advantages and classification of NC systems, input media.

**Module 2:**

Design consideration of NC machine tools - machining centre – MCU functions. Controls and System devices Control loops of NC system – CNC Concepts, reference pulse and sampled data techniques – microprocessor and CNC adaptive control – ACO and ACC systems. Graphical Numerical Control - part programming - design of post Processor

**Module 3:**

Digital incremental: displacement measuring systems – Incremental rotary encoders – Digital absolute measuring system – Electromagnetic Analog position transducers. Programmable machine control – PLC - CNC and PLC – Components of PLC – Architecture of PLC – Programming a PLC

**Module 4:**

Manual part programming: Computer aided part programming, Need for computer aided part programming, Tools for computer aided part programming, APT, COMPACT II, CAD/CAM based part programming G Code, M Code– post processor, APT programming.

**Module 5:**

Programming for CNC turning center, Machining center and CNC EDM and wire cut EDM.  
Computer Aided Process Planning: Introduction, Manual process planning vs. Computer aided

  
PRINCIPAL

Nehru College of  
Engineering and Research Centre  
Campus, Thiruvananthapuram, Thiruvananthapuram  
Pin: 696 007, Kerala

process planning, Basics of variant and generative process planning methods, Examples of automated process planning systems.

**Course Outcome:**

The student will have acquired

- Knowledge of CNC machine tools and machining centres
- Knowledge of CNC concepts with ability to perform CNC Programming
- Knowledge of constructional features of CNC machine tools
- Knowledge of adaptive control of CNC machines

**Reference Books:**

1. Yoram Koren, Computer Control of Manufacturing Systems, McGraw-Hill Book Company, 2005.
2. P. Radhakrishnan, Computer Numerical Control and Computer Aided Manufacture, New Age International Publishers, 2012.
3. P. Radhakrishnan, S. Subramanyan, V. Raju CAD/CAM/CIM, New Age International Publishers, 2009.
4. Madhuchandra Mitra and Samarjit Sen Gupta, PLC and Industrial Automation, Penram Industrial Publishing (India) (P) Ltd., 2009.



  
PRINCIPAL  
Nehru College of  
Engineering and Research Centre  
Pampady, Thrissur, Kerala  
Pin - 680 097 Kerala

**NEHRU COLLEGE OF ENGINEERING AND RESEARCH CENTRE**  
(NAAC Accredited, Affiliated to University of Calicut, Kerala Technological University)

**DEPARTMENT OF MECHANICAL ENGINEERING**

**CNC MACHINES, CONTROLS AND PART PROGRAMMING**

LECTURE PLAN	
TOPICS	DATE
<b>MODULE 1</b>	
Automation strategies, Devices, drives and control	02/02/2016
Mechanical, Pneumatic, electrical, hydraulic electronic and hybrid automation system	03/02/2016
Comparative evaluation of automation system	04/02/2016
Concept and classification of NC System, input media	05/02/2016
<b>MODULE 2</b>	
Design consideration of NC machine tools	06/02/2016
Machining centre, MCU functions, Control and system devices	06/02/2016
Control loop, CNC concept, reference pulse , sampled data	08/02/2016
NC control, part programming, Design of post processor	09/02/2016
<b>MODULE 3</b>	
Digital increment, displacement measuring system	10/02/2016
Incrementary rotor encoder, Digital absolute measuring system	11/02/2016
Electromagnetic analog position transducer, PLC	12/02/2016
Components of PLC, Architecture of PLC, Programming of PLC	2/15/2016
<b>MODULE 4</b>	
Manual part programming, Computer aided part programming	2/16/2016
Tool for computer aided part programming, APT, COMPACT II	2/17/2016
CAD/CAM Based programming: G- Codes, M- codes,	18/02/2015
APT Programming	2/19/2016
<b>MODULE 5</b>	
Programming of CNC Turning centre, EDM	2/20/2016
Computer aided process planning, Manual process planning	2/20/2016
Basic of generative and variant planning methods	2/22/2016
Examples of automated planning system	2/23/2016
End course examination	2/25/2016

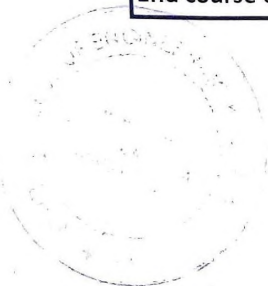

**PRINCIPAL**  
 Nehru College of  
 Engineering and Research Centre  
 P.O. Box 11, Manjerappada, Talassery, Uj  
 Pin - 680 097 Kerala

**NEHRU COLLEGE OF ENGINEERING AND RESEARCH CENTRE, PAMPADY, THRISSUR**  
**DEPARTMENT OF MECHANICAL ENGINEERING**  
**ENROLLMENT LIST**

COURSE NAME: CNC MACHINES, CONTROLS AND PART PROGRAMMING  
 ACADEMIC YEAR: 2015-16

PROGRAM COORDINATOR: Mr. PRASHOB M A

SL.NO	REG NO	NAME	SL.NO	REG NO	NAME
1	NCAOEME001	AADITH K JAYARAJ	77	NCAOEME082	RANJITH K
2	NCAOEME002	ABEL ELIAS	78	NCAOEME083	RIJAS S
3	NCAOEME125	ABHIJITH A	79	NCAOEME084	ROJITH S THATTIL
4	NCAOEME003	ABHILASH C	80	NCAOEME085	ROSHIN K.H
5	NCAOEME004	ABHILASH P MOHAN	81	NCAOEME086	SAANU SADANAND
6	NCAOEME005	ACHUTH KAILAS E	82	NCAOEME087	SACHINDEV V
7	NCAOEME006	ADARSH A	83	NCAOEME088	SAJEEV A S
8	NCAOEME007	ADARSH CHANDRA	84	NCAOEME089	SAJITH S
9	NCAOEME008	ADHARSH K T	85	NCAOEME090	SANDEEP KUMAR K P
10	NCAOEME009	ADITH VARMA M	86	NCAOEME091	SANEESH M
11	NCAOEME010	AJAY SEKSHAR	87	NCAOEME092	SANGEETH NARAYAN B
12	NCAOEME126	AJITH P BABU	88	NCAOEME093	SANJAY C
13	NCAOEME011	AKHIL KRISHNAN M.A	89	NCAOEME095	SARATH ARAVIND S
14	NCAOEME012	AKSHAY MOHANDAS	90	NCAOEME096	SARATH C
15	NCAOEME013	AKSHAY P	91	NCAOEME097	SATHEESH R
16	NCAOEME014	AKSHAY SANTHOSH	92	NCAOEME098	SHARATH JAYAKRISHNAN
17	NCAOEME072	AKSHAYDAS NP	93	NCAOEME128	SHOYAB MOHAMED SHELLY
18	NCAOEME016	AMAL SANKAR T S	94	NCAOEME099	SHRAVAN K
19	NCAOEME017	AMEER SUHAIL	95	NCAOEME100	SIDDHARTH G S
20	NCAOEME018	AMRITHESH M	96	NCAOEME101	SOORAJ BHASKARAN
21	NCAOEME019	ANEESH KRISHNAN P	97	NCAOEME102	SOORYAJITH
22	NCAOEME020	ANSAR S	98	NCAOEME129	SREEJITH K
23	NCAOEME021	ANWAR P A	99	NCAOEME103	SREEJITH K P
24	NCAOEME023	ARJUN A.S	100	NCAOEME104	SREEJITH S DEVAN
25	NCAOEME133	ARJUNLAL A.C	101	NCAOEME105	SREERAG M
26	NCAOEME024	ARSHAQ K S	102	NCAOEME106	SREERAG S
27	NCAOEME025	ARUN GOPINATHAN KUNNATH	103	NCAOEME108	SUBIN D STEPHEN
28	NCAOEME026	ARUN K	104	NCAOEME109	SUHAIL K.M
29	NCAOEME027	ARUN S	105	NCAOEME110	SYAMJITH K
30	NCAOEME029	ASHWIN NAIR	106	NCAOEME131	TINUKRISHNAN P
31	NCAOEME030	ASWAN KRISHNA R	107	NCAOEME121	VARUN SWAMY V
32	NCAOEME032	ATHUL T.S	108	NCAOEME112	VJESH M V
33	NCAOEME033	BARATH M	109	NCAOEME130	VINEETH VARIYAR
34	NCAOEME034	BIJU P.M	110	NCAOEME113	VIPUL VISWANATHAN
35	NCAOEME035	BIMAL BAIJU C	111	NCAOEME114	VISAL P
36	NCAOEME036	DEVNATH C.D	112	NCAOEME115	VISHNU BHASKAR R
37	NCAOEME037	DHANEESH KRISHNAN	113	NCAOEME116	VISHNU M
38	NCAOEME038	DILEEP M	114	NCAOEME117	VISHNU SHANKAR
39	NCAOEME039	GANESH S	115	NCAOEME118	VISHNU T.G
40	NCAOEME040	GOKUL P MENON	116	NCAOEME119	VIVEK SANKAR P
41	NCAOEME132	JIBIN C.K	117	NCAOEME120	VIVEK V NAIR
42	NCAOEME041	JISHNU MADHAVAN	118	NCAOEME122	VYSHAK K
43	NCAOEME042	JITHIN KRISHNA A.P	119	NCAOEME123	YADHUKRISHNA A
44	NCAOEME043	JITTO GEORGE	120	NCAOEME124	YADUKRISHNAN V
45	NCAOEME044	KINAYATH SACHIN MENON	121		ABDUL LATHEEF A
46	NCAOEME046	KIRAN KRISHNA P.S	122		ABDULLA S
47	NCAOEME045	KIRANDAS PR	123		ABEJITH D
48	NCAOEME047	KISHAN S MOHAN	124		ABHIJITH V NAIR
49	NCAOEME048	LINTO T PALAYOOR	125		ABHIJITH.P
50	NCAOEME127	MANOJ K P	126		ABHISHEK SUNIL
51	NCAOEME049	MANSUR K M	127		ABIJITH B
52	NCAOEME050	MIDHUN A	128		ADVAIDH H
53	NCAOEME051	MIDHUN M	129		AJITH C
54	NCAOEME052	MINHAJ P	130		AJITH K A
55	NCAOEME053	MOHAMED SAFEER CHEMBAKASSERI	131		AJITH P V
56	NCAOEME054	MOHAMMED NIBIL P.K	132		AJMAL K P
57	NCAOEME055	MOHAMMED RIFAD	133		AJMAL P
58	NCAOEME056	MOHAMMED RISAL	134		MELVIN JOHNSON
59	NCAOEME057	MOHAMMED SALIH N.P	135		MITHUN GOPINATH
60	NCAOEME058	MOHAMMED SHIBIN P	136		MOHAMED JASIL C
61	NCAOEME063	NAIR VINAY SASIKUMAR	137		MOHAMMED SAFARULLA H
62	NCAOEME064	NAKUL A.R	138		MUHAMMED KUNHI. M P
63	NCAOEME065	NANDAGOPAL V V	139		NAJMAL K JAMAL
64	NCAOEME066	NAVEEN S	140		NANDAGOPAN K S
65	NCAOEME067	NAZRUL AZLAM	141		NIDHIN KRISHNAN K
66	NCAOEME068	NIBINLAL PT	142		NIJIL C R
67	NCAOEME069	NIDHIN MOHAN P	143		SUDHEESH C
68	NCAOEME070	NIKHIL J	144		SUDHISH SOMAKUMAR NAIR
69	NCAOEME073	PRAKHIL P	145		VYSHAKH P
70	NCAOEME074	RAHUL M	146		YADHUKRISHNA M
71	NCAOEME075	RAHUL MURALI P	147		YADHUKRISHNAN C H
72	NCAOEME077	RAKESH P R	148		VYSHAKH V
73	NCAOEME078	RAMACHANDRAN S			
74	NCAOEME079	RAMDAS M			
75	NCAOEME080	RAMSHEER P			
76	NCAOEME081	RANJI R			

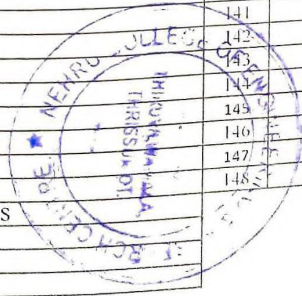

*(Handwritten signature)*

**PRINCIPAL**  
 Nehru College of  
 Engineering and Research Centre,  
 Pampady, Thrissur  
 PROGRAM COORDINATOR: Mr. PRASHOB M A

**NEHRU COLLEGE OF ENGINEERING AND RESEARCH CENTRE, PAMPADY, THRISSUR**  
**DEPARTMENT OF MECHANICAL ENGINEERING**  
**ATTENDANCE REGISTER**

YEAR: 2015-16

COURSE: CNC MACHINES, CONTROLS AND PART PROGRAMMING

FACULTY-IN-CHARGE: Mr. PRASHOB M A

Sl. No	Reg No	Name	DATES																								
			2/2	3/2	4/2	5/2	6/2	7/2	8/2	9/2	10/2	11/2	12/2	13/2	14/2	15/2	16/2	17/2	18/2	19/2	20/2	21/2	22/2	23/2	24/2	25/2	
1	NCAOEME001	AADITH K JAYARAJ	/	/	/	/	/	/	/	/	/	/	/	/	/	/	/	/	/	/	/	/	/	/	/		
2	NCAOEME002	ABEL ELIAS	/	/	/	/	/	/	/	/	/	/	/	/	/	/	/	/	/	/	/	/	/	/	/		
3	NCAOEME125	ABHIJITH A	/	/	/	/	/	/	/	/	/	/	/	/	/	/	/	/	/	/	/	/	/	/	/		
4	NCAOEME003	ABHILASH C	/	/	/	/	/	/	/	/	/	/	/	/	/	/	/	/	/	/	/	/	/	/	/		
5	NCAOEME004	ABHILASH P MOHAN	/	/	/	/	/	/	/	/	/	/	/	/	/	/	/	/	/	/	/	/	/	/	/		
6	NCAOEME005	ACHUTH KAILAS E	/	/	/	/	/	/	/	/	/	/	/	/	/	/	/	/	/	/	/	/	/	/	/		
7	NCAOEME006	ADARSH A	/	/	/	/	/	/	/	/	/	/	/	/	/	/	/	/	/	/	/	/	/	/	/		
8	NCAOEME007	ADARSH CHANDRA	/	/	/	/	/	/	/	/	/	/	/	/	/	/	/	/	/	/	/	/	/	/	/		
9	NCAOEME008	ADHARSH K T	/	/	/	/	/	/	/	/	/	/	/	/	/	/	/	/	/	/	/	/	/	/	/		
10	NCAOEME009	ADITH VARMA M	/	/	/	/	/	/	/	/	/	/	/	/	/	/	/	/	/	/	/	/	/	/	/		
11	NCAOEME010	AJAY SEKCHAR	/	/	/	/	/	/	/	/	/	/	/	/	/	/	/	/	/	/	/	/	/	/	/		
12	NCAOEME126	AJITH P BABU	/	/	/	/	/	/	/	/	/	/	/	/	/	/	/	/	/	/	/	/	/	/	/		
13	NCAOEME011	AKHIL KRISHNAN M.A	/	/	/	/	/	/	/	/	/	/	/	/	/	/	/	/	/	/	/	/	/	/	/		
14	NCAOEME012	AKSHAY MOHANDAS	/	/	/	/	/	/	/	/	/	/	/	/	/	/	/	/	/	/	/	/	/	/	/		
15	NCAOEME013	AKSHAY P	/	/	/	/	/	/	/	/	/	/	/	/	/	/	/	/	/	/	/	/	/	/	/		
16	NCAOEME014	AKSHAY SANTHOSH	/	/	/	/	/	/	/	/	/	/	/	/	/	/	/	/	/	/	/	/	/	/	/		
17	NCAOEME072	AKSHAYDAS NP	/	/	/	/	/	/	/	/	/	/	/	/	/	/	/	/	/	/	/	/	/	/	/		
18	NCAOEME016	AMAL SANKAR T S	/	/	/	/	/	/	/	/	/	/	/	/	/	/	/	/	/	/	/	/	/	/	/		
19	NCAOEME017	AMEER SUHAIL	/	/	/	/	/	/	/	/	/	/	/	/	/	/	/	/	/	/	/	/	/	/	/		
20	NCAOEME018	AMRITHESH M	/	/	/	/	/	/	/	/	/	/	/	/	/	/	/	/	/	/	/	/	/	/	/		
21	NCAOEME019	ANEESH KRISHNAN P	/	/	/	/	/	/	/	/	/	/	/	/	/	/	/	/	/	/	/	/	/	/	/		
22	NCAOEME020	ANSAR S	/	/	/	/	/	/	/	/	/	/	/	/	/	/	/	/	/	/	/	/	/	/	/		
23	NCAOEME021	ANWAR P A	/	/	/	/	/	/	/	/	/	/	/	/	/	/	/	/	/	/	/	/	/	/	/		
24	NCAOEME023	ARJUN A.S	/	/	/	/	/	/	/	/	/	/	/	/	/	/	/	/	/	/	/	/	/	/	/		
25	NCAOEME133	ARJUNLAL A.C	/	/	/	/	/	/	/	/	/	/	/	/	/	/	/	/	/	/	/	/	/	/	/		
26	NCAOEME024	ARSHAQ K S	/	/	/	/	/	/	/	/	/	/	/	/	/	/	/	/	/	/	/	/	/	/	/		
27	NCAOEME025	ARUN GOPINATHAN K	/	/	/	/	/	/	/	/	/	/	/	/	/	/	/	/	/	/	/	/	/	/	/		
28	NCAOEME026	ARUN K	/	/	/	/	/	/	/	/	/	/	/	/	/	/	/	/	/	/	/	/	/	/	/		
29	NCAOEME027	ARUN S	/	/	/	/	/	/	/	/	/	/	/	/	/	/	/	/	/	/	/	/	/	/	/		
30	NCAOEME029	ASHWIN NAIR	/	/	/	/	/	/	/	/	/	/	/	/	/	/	/	/	/	/	/	/	/	/	/		
31	NCAOEME030	ASWAN KRISHNA R	/	/	/	/	/	/	/	/	/	/	/	/	/	/	/	/	/	/	/	/	/	/	/		
32	NCAOEME032	ATHUL T.S	/	/	/	/	/	/	/	/	/	/	/	/	/	/	/	/	/	/	/	/	/	/	/		
33	NCAOEME033	BARATH M	/	/	/	/	/	/	/	/	/	/	/	/	/	/	/	/	/	/	/	/	/	/	/		
34	NCAOEME034	BIJU P.M	/	/	/	/	/	/	/	/	/	/	/	/	/	/	/	/	/	/	/	/	/	/	/		
35	NCAOEME035	BIMAL BAIJU C	/	/	/	/	/	/	/	/	/	/	/	/	/	/	/	/	/	/	/	/	/	/	/		
36	NCAOEME036	DEVNATH C.D	/	/	/	/	/	/	/	/	/	/	/	/	/	/	/	/	/	/	/	/	/	/	/		
37	NCAOEME037	DHANEESH KRISHNAN	/	/	/	/	/	/	/	/	/	/	/	/	/	/	/	/	/	/	/	/	/	/	/		
38	NCAOEME038	DILEEP M	/	/	/	/	/	/	/	/	/	/	/	/	/	/	/	/	/	/	/	/	/	/	/		
39	NCAOEME039	GANESH S	/	/	/	/	/	/	/	/	/	/	/	/	/	/	/	/	/	/	/	/	/	/	/		
40	NCAOEME040	GOKUL P MENON	/	/	/	/	/	/	/	/	/	/	/	/	/	/	/	/	/	/	/	/	/	/	/		
41	NCAOEME132	JIBIN C.K	/	/	/	/	/	/	/	/	/	/	/	/	/	/	/	/	/	/	/	/	/	/	/		
42	NCAOEME041	JISHNU MADHAVAN	/	/	/	/	/	/	/	/	/	/	/	/	/	/	/	/	/	/	/	/	/	/	/		
43	NCAOEME042	JITHIN KRISHNA A.P	/	/	/	/	/	/	/	/	/	/	/	/	/	/	/	/	/	/	/	/	/	/	/		
44	NCAOEME043	JITTO GEORGE	/	/	/	/	/	/	/	/	/	/	/	/	/	/	/	/	/	/	/	/	/	/	/		
45	NCAOEME044	KINAYATH SACHIN MENON	/	/	/	/	/	/	/	/	/	/	/	/	/	/	/	/	/	/	/	/	/	/	/		
46	NCAOEME046	KIRAN KRISHNA P.S	/	/	/	/	/	/	/	/	/	/	/	/	/	/	/	/	/	/	/	/	/	/	/		
47	NCAOEME045	KIRANDAS PR	/	/	/	/	/	/	/	/	/	/	/	/	/	/	/	/	/	/	/	/	/	/	/		
48	NCAOEME047	KISHAN S MOHAN	/	/	/	/	/	/	/	/	/	/	/	/	/	/	/	/	/	/	/	/	/	/	/		
49	NCAOEME048	LINTO T PALAYOOR	/	/	/	/	/	/	/	/	/	/	/	/	/	/	/	/	/	/	/	/	/	/	/		
50	NCAOEME127	MANOJ K P	/	/	/	/	/	/	/	/	/	/	/	/	/	/	/	/	/	/	/	/	/	/	/		
51	NCAOEME049	MANSUR K M	/	/	/	/	/	/	/	/	/	/	/	/	/	/	/	/	/	/	/	/	/	/	/		
52	NCAOEME050	MIDHUN A	/	/	/	/	/	/	/	/	/	/	/	/	/	/	/	/	/	/	/	/	/	/	/		
53	NCAOEME051	MIDHUN M	/	/	/	/	/	/	/	/	/	/	/	/	/	/	/	/	/	/	/	/	/	/	/		
54	NCAOEME052	MINHAJ P	/	/	/	/	/	/	/	/	/	/	/	/	/	/	/	/	/	/	/	/	/	/	/		
55	NCAOEME053	MOHAMED SAFEER C	/	/	/	/	/	/	/	/	/	/	/	/	/	/	/	/	/	/	/	/	/	/	/		
56	NCAOEME054	MOHAMMED NIBIL P.K	/	/	/	/	/	/	/	/	/	/	/	/	/	/	/	/	/	/	/	/	/	/	/		
57	NCAOEME055	MOHAMMED RIFAD	/	/	/	/	/	/	/	/	/	/	/	/	/	/	/	/	/	/	/	/	/	/	/		
58	NCAOEME056	MOHAMMED RISAL	/	/	/	/	/	/	/	/	/	/	/	/	/	/	/	/	/	/	/	/	/	/	/		
59	NCAOEME057	MOHAMMED SALIH N.P	/	/	/	/	/	/	/	/	/	/	/	/	/	/	/	/	/	/	/	/	/	/	/		
60	NCAOEME058	MOHAMMED SHIBIN P	/	/	/	/	/	/	/	/	/	/	/	/	/	/	/	/	/	/	/	/	/	/	/		
61	NCAOEME059	NAIR VINAY SASIKUMAR	/	/	/	/	/	/	/	/	/	/	/	/	/	/	/	/	/	/	/	/	/	/	/		

PRINCIPAL  
 Nehru College of  
 Engineering and Research Centre  
 Pampady, Thrissur Dt.







# NEHRU COLLEGE OF ENGINEERING AND RESEARCH CENTRE

(NAAC Accredited)

## DEPARTMENT OF MECHANICAL ENGINEERING

END COURSE EXAMINATION



Course: **CNC MACHINES, CONTROLS AND PART PROGRAMMING**

Date: 23<sup>rd</sup> February, 2016

Total Marks: **50**

Total Duration: **1 hour**

- Put a tick towards the right answer.
- If multiple options are chosen for a question it will not be considered for evaluation.
- Attend all the questions.
- There will be no negative marking.

Name: \_\_\_\_\_

Register Number: \_\_\_\_\_

Semester/Year: \_\_\_\_\_

*Each question carries 2 marks*

1) Arrange the below operations in operator controlled machine tool in correct order.

(A) Operator (B) Process planning (C) Machine tool (D) Component drawing (E) Completed component

- a. (A) – (D) – (B) – (C) – (E)
- b. (D) – (B) – (C) – (A) – (E)
- c. (B) – (D) – (C) – (A) – (E)
- d. (D) – (B) – (A) – (C) – (E)

2) The device, fed to the control unit of NC machine tool which sends the position command signals to sideway transmission elements of the machine, is called as

- a. controller
- b. tape
- c. feedback unit
- d. none of the above

3) In NC (Numerical Control) machine tool, the position feedback package is connected between

- a. control unit and programmer
- b. programmer and machine tool
- c. control unit and machine tool
- d. programmer and process planning

4) Which of the following options is correct for the control unit and panel of NC (Numerical Control) and CNC (Computer Numerical Control) machine tools?

- a. The control unit of NC machine tool works in ON-line mode and the control unit of CNC machine tool works in batch processing mode

*[Signature]*  
 PRINCIPAL  
 Nehru College of  
 Engineering and Research Centre  
 1968

b. The control unit of NC machine tool works in batch processing mode and the control unit of CNC machine tool works in ON-line mode

c. The control units of both NC and CNC machines work in ON-line mode

d. The control units of both NC and CNC machines work in batch processing mode

5) In CNC machine tool, the part program entered into the computer memory

a. can be used only once

b. can be used again and again

c. can be used again but it has to be modified every time

d. cannot say

6) Which of the following statements are correct for CNC machine tool?

1. CNC control unit does not allow compensation for any changes in the dimensions of cutting tool

2. CNC machine tool are suitable for long run applications

3. It is possible to obtain information on machine utilization which is useful to management in CNC machine tool

4. CNC machine tool has greater flexibility

5. CNC machine can diagnose program and can detect the machine defects even before the part is produced

a. (1), (2) and (3)

b. (2), (4) and (5)

c. (3), (4) and (5)

d. (2), (3), (4) and (5)

7) Several machine tools can be controlled by a central computer in

a. NC (Numerical Control) machine tool

b. CNC (Computer Numerical Control) machine tool

c. DNC (Direct Numerical Control) machine tool

d. CCNC (Central-Computer Numerical Control) machine tool

8) Part-programming mistakes can be avoided in

a. NC (Numerical Control) machine tool

b. CNC (Computer Numerical Control) machine tool

c. Both a. and b.

d. None of the above

9) The machine tool, in which calculation and setting of the operating conditions like depth of cut, feed, speed are done during the machining by the control system itself, is called

a. Computer Numerical Control System

b. Direct Numerical Control System

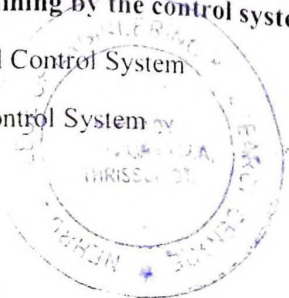

Handwritten signature in green ink.

Principal  
Neeru College of  
Engineering and Research Centre 2  
Muvattupuzha, Thrissur Dt  
Pin - 686 007, Kerala

c. Machining Centre System

d. Adaptive Control System

**10) Which machine tool reduces the number of set-ups in machining operation, time spent in setting machine tools and transportation between sections of machines?**

a. Computer Numerical Control machine tool

b. Direct Numerical Control machine tool

c. Adaptive Control Systems

d. Machining centre

**11. Which of the following code will give point to point movement?**

a) G00

b) G01

c) G56

d) G94

**12. Which of the following code will give linear interpolation movement?**

a) G00

b) G01

c) G78

d) G65

**13. Which of the following code will give circular interpolation in a clockwise direction?**

a) G56

b) G01

c) G02

d) G47

**14. Which of the following code will give circular interpolation in Counterclockwise direction?**

a) G00

b) G56

c) G69

d) G03

**15. Which the following code will produce dwell for a specified time?**

a) G18

b) G65

c) G45

d) G04



*Handwritten signature*

Dr. M. S. K. S. S. S.  
 Director, Research Centre  
 College of Engineering, Thiruvananthapuram  
 P.O. No. 1, Thiruvananthapuram

16. Which of the following code is used to give input of cutter offset data?

- a) G30
- b) G20
- c) G10
- d) G04

17. Which of the following code is used to select x y plane in milling?

- a) G18
- b) G17
- c) G10
- d) G04

18. Which of the following code is used to select x z plane in milling?

- a) G18
- b) G17
- c) G10
- d) G04

19. Which of the following code is used to select y-z plane in milling?

- a) G32
- b) G00
- c) G02
- d) G19

20. Which of the following code will change specified input values in millimeters?

- a) G01
- b) G00
- c) G20

21. Which of the following code is used to return to a reference point?

- a) G23
- b) G28
- c) G14
- d) G19

22. Which of the following code is used in thread cutting in turning?

- a) G32
- b) G89

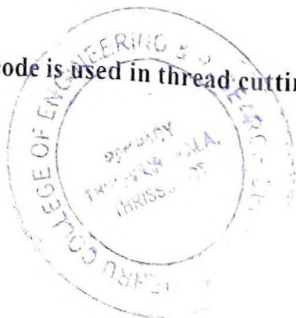

  
 PRINCIPAL  
 Mairu College of  
 Engineering and Research Centre  
 Pattambi, Thiruvananthapuram, Kerala  
 Pin - 695014

c) G20

d) G74

23. Which of the following code is used to cancel offset compensation for cutter radius?

a) G40

b) G02

c) G42

d) G00

24. Which of the following code is used to give cutter offset compensation, left of a part surface?

a) G40

b) G41

c) G42

d) G50

25. Which of the following code is used to give cutter offset compensation, right of a part surface?

a) G00

b) G41

c) G42

d) G91

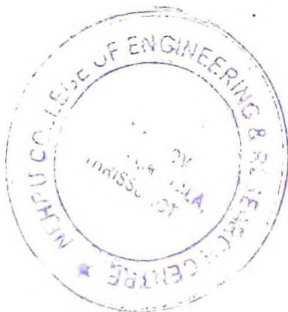

A handwritten signature in green ink, consisting of a stylized 'C' followed by a horizontal line.

PRINCIPAL

Nehru College of

Engineering and Research Centre

Warananagar, Maharashtra

2015-16 C3

## CNC MACHINES, CONTROLS AND PART PROGRAMMING

### ANSWER KEY

1. ANSWER: d
2. ANSWER: b
3. ANSWER: c
4. ANSWER: b
5. ANSWER: b
6. ANSWER: c
7. ANSWER: c
8. ANSWER: b
9. ANSWER: d
10. ANSWER: d
11. ANSWER: a
12. ANSWER: b
13. ANSWER: c
14. ANSWER: d
15. ANSWER: d
16. ANSWER: c
17. ANSWER: b
18. ANSWER: a
19. ANSWER: d
20. ANSWER: c
21. ANSWER: b
22. ANSWER: a
23. ANSWER: a
24. ANSWER: b
25. ANSWER: c

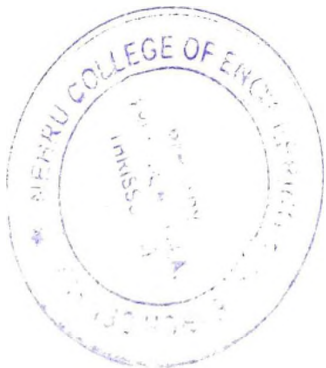

A handwritten signature in green ink, consisting of a stylized 'U' shape with a horizontal line extending to the right.

**PRINCIPAL**  
Nehru College of  
Engineering and Research Centre  
Thiruvananthapuram, Thiruvananthapuram  
Pin - 680 597 Kerala



# NEHRU COLLEGE OF ENGINEERING AND RESEARCH CENTRE

(NAAC Accredited)

## DEPARTMENT OF MECHANICAL ENGINEERING

### END COURSE EXAMINATION

Course: CNC MACHINES, CONTROLS AND PART PROGRAMMING

Date: 23<sup>rd</sup> February, 2016

Total Marks: 50

Total Duration: 1 hour

- Put a tick towards the right answer.
- If multiple options are chosen for a question it will not be considered for evaluation.
- Attend all the questions.
- There will be no negative marking.

48/50

Name: Vishnu M

Register Number: NCAOEMG16

Semester/Year: 2<sup>nd</sup> / 2<sup>nd</sup> year

Each question carries 2 marks

1) Arrange the below operations in operator controlled machine tool in correct order.

(A) Operator (B) Process planning (C) Machine tool (D) Component drawing (E) Completed component

- (A) – (D) – (B) – (C) – (E)
- (D) – (B) – (C) – (A) – (E)
- (B) – (D) – (C) – (A) – (E)
- (D) – (B) – (A) – (C) – (E) ✓

2) The device, fed to the control unit of NC machine tool which sends the position command signals to sideway transmission elements of the machine, is called as

- controller
- tape ✓
- feedback unit
- none of the above

3) In NC (Numerical Control) machine tool, the position feedback package is connected between

- control unit and programmer
- programmer and machine tool
- control unit and machine tool ✓
- programmer and process planning

4) Which of the following options is correct for the control unit and panel of NC (Numerical Control) and CNC (Computer Numerical Control) machine tools?

- The control unit of NC machine tool works in ON-line mode and the control unit of CNC machine tool works in batch processing mode ✓

PRINCIPAL

Nehru College of  
Engineering and Research Centre  
K. S. S. Road, Thiruvananthapuram, Thiruvananthapuram  
Pin - 696 007, Kerala

b. The control unit of NC machine tool works in batch processing mode and the control unit of CNC machine tool works in ON-line mode ✓

c. The control units of both NC and CNC machines work in ON-line mode

d. The control units of both NC and CNC machines work in batch processing mode

**5) In CNC machine tool, the part program entered into the computer memory**

a. can be used only once

b. can be used again and again ✓

c. can be used again but it has to be modified every time

d. cannot say

**6) Which of the following statements are correct for CNC machine tool?**

1. CNC control unit does not allow compensation for any changes in the dimensions of cutting tool

2. CNC machine tool are suitable for long run applications

3. It is possible to obtain information on machine utilization which is useful to management in CNC machine tool

4. CNC machine tool has greater flexibility

5. CNC machine can diagnose program and can detect the machine defects even before the part is produced

a. (1), (2) and (3)

b. (2), (4) and (5)

c. (3), (4) and (5) ✓

d. (2), (3), (4) and (5)

**7) Several machine tools can be controlled by a central computer in**

a. NC (Numerical Control) machine tool

b. CNC (Computer Numerical Control) machine tool

c. DNC (Direct Numerical Control) machine tool ✓

d. CCNC (Central-Computer Numerical Control) machine tool

**8) Part-programming mistakes can be avoided in**

a. NC (Numerical Control) machine tool

b. CNC (Computer Numerical Control) machine tool ✓

c. Both a. and b.

d. None of the above

**9) The machine tool, in which calculation and setting of the operating conditions like depth of cut, feed, speed are done during the machining by the control system itself, is called**

a. Computer Numerical Control System

b. Direct Numerical Control System

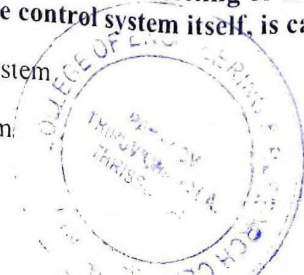

Principal

Principal

Principal

Principal

Principal

c. Machining Centre System

d. Adaptive Control System ✓

**10) Which machine tool reduces the number of set-ups in machining operation, time spent in setting machine tools and transportation between sections of machines?**

a. Computer Numerical Control machine tool

b. Direct Numerical Control machine tool

c. Adaptive Control Systems

d. Machining centre ✓

**11. Which of the following code will give point to point movement?**

a) G00 ✓

b) G01

c) G56

d) G94

**12. Which of the following code will give linear interpolation movement?**

a) G00

b) G01 ✓

c) G78

d) G65

**13. Which of the following code will give circular interpolation in a clockwise direction?**

a) G56

b) G01 ✓

c) G02

d) G47

**14. Which of the following code will give circular interpolation in Counterclockwise direction?**

a) G00

b) G56

c) G69

d) G03 ✓

**15. Which the following code will produce dwell for a specified time?**

a) G18

b) G65

c) G45

d) G04 ✓

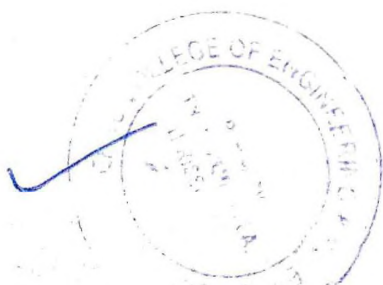

PRINCIPAL

Naluru College of  
Engineering and Research Centre  
N. COLLEGE OF ENGINEERING & TECHNOLOGY  
N. COLLEGE OF ENGINEERING & TECHNOLOGY

16. Which of the following code is used to give input of cutter offset data?

- a) G30
- b) G20
- c) G10 ✓
- d) G04

17. Which of the following code is used to select x y plane in milling?

- a) G18
- b) G17 ✓
- c) G10
- d) G04

18. Which of the following code is used to select x z plane in milling?

- a) G18 ✓
- b) G17
- c) G10
- d) G04

19. Which of the following code is used to select y-z plane in milling?

- a) G32
- b) G00
- c) G02
- d) G19 ✓

20. Which of the following code will change specified input values in millimeters?

- a) G01
- b) G00
- c) G20 ✓

21. Which of the following code is used to return to a reference point?

- a) G23
- b) G28 ✓
- c) G14
- d) G19

22. Which of the following code is used in thread cutting in turning?

- a) G32 ✓
- b) G89

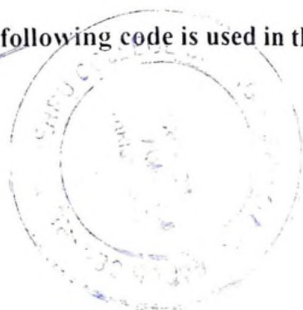

  
PRINCIPAL  
Nehru College of  
Engineering and Research Centre  
Siddhanta, Solapur, Maharashtra  
413 149, Solapur, India

c) G20

d) G74

23. Which of the following code is used to cancel offset compensation for cutter radius?

a) G40 ✓

b) G02

c) G42

d) G00

24. Which of the following code is used to give cutter offset compensation, left of a part surface?

a) G40

b) G41 ✓

c) G42

d) G50

25. Which of the following code is used to give cutter offset compensation, right of a part surface?

a) G00

b) G41

c) G42 ✓

d) G91



  
PRINCIPAL  
Nehru College of  
Engineering and Research Center  
T. Narayana W. Thimmatwamala, Thesauri Dt.  
Pin - 576 397, Kerala



**NEHRU COLLEGE OF ENGINEERING AND RESEARCH CENTRE**

*(NAAC Accredited)*

**DEPARTMENT OF MECHANICAL ENGINEERING**

**END COURSE EXAMINATION**



Course: **CNC MACHINES, CONTROLS AND PART PROGRAMMING**

Date: 23<sup>rd</sup> February, 2016

Total Marks: **50**

Total Duration: **1 hour**

- Put a tick towards the right answer.
- If multiple options are chosen for a question it will not be considered for evaluation.
- Attend all the questions.
- There will be no negative marking.

Name: Aswain Nair

Register Number: NCA01EME029

Semester/Year: IV/II

44/50

*Each question carries 2 marks*

**1) Arrange the below operations in operator controlled machine tool in correct order.**

(A) Operator (B) Process planning (C) Machine tool (D) Component drawing (E) Completed component

- a. (A) – (D) – (B) – (C) – (E)
- b. (D) – (B) – (C) – (A) – (E)
- c. (B) – (D) – (C) – (A) – (E)
- d.  (D) – (B) – (A) – (C) – (E)

**2) The device, fed to the control unit of NC machine tool which sends the position command signals to sideway transmission elements of the machine, is called as**

- a. controller
- b.  tape
- c. feedback unit
- d. none of the above

**3) In NC (Numerical Control) machine tool, the position feedback package is connected between**

- a. control unit and programmer
- b. programmer and machine tool
- c.  control unit and machine tool
- d. programmer and process planning

**4) Which of the following options is correct for the control unit and panel of NC (Numerical Control) and CNC (Computer Numerical Control) machine tools?**

- a. The control unit of NC machine tool works in ON-line mode and the control unit of CNC machine tool works in batch processing mode

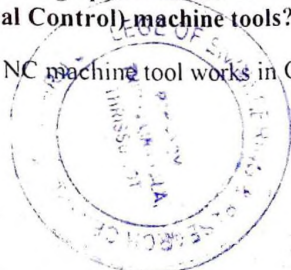

PRINCIPAL  
Nehru College of  
Engineering and Research Centre  
P.O. Box 10, K. J. Somaiya Road, Thane (W)  
Mumbai - 400 022

b.  The control unit of NC machine tool works in batch processing mode and the control unit of CNC machine tool works in ON-line mode

c. The control units of both NC and CNC machines work in ON-line mode

d. The control units of both NC and CNC machines work in batch processing mode

5) **In CNC machine tool, the part program entered into the computer memory**

a. can be used only once

b.  can be used again and again

c. can be used again but it has to be modified every time

d. cannot say

6) **Which of the following statements are correct for CNC machine tool?**

1. CNC control unit does not allow compensation for any changes in the dimensions of cutting tool

2. CNC machine tool are suitable for long run applications

3. It is possible to obtain information on machine utilization which is useful to management in CNC machine tool

4. CNC machine tool has greater flexibility

5. CNC machine can diagnose program and can detect the machine defects even before the part is produced

a. (1), (2) and (3)

b. (2), (4) and (5)

c.  (3), (4) and (5)

d. (2), (3), (4) and (5)

7) **Several machine tools can be controlled by a central computer in**

a. NC (Numerical Control) machine tool

b. CNC (Computer Numerical Control) machine tool

c.  DNC (Direct Numerical Control) machine tool

d. CCNC (Central-Computer Numerical Control) machine tool

8) **Part-programming mistakes can be avoided in**

a. NC (Numerical Control) machine tool

b.  CNC (Computer Numerical Control) machine tool

c. Both a. and b.

d. None of the above

9) **The machine tool, in which calculation and setting of the operating conditions like depth of cut, feed, speed are done during the machining by the control system itself, is called**

a. Computer Numerical Control System

b.  Direct Numerical Control System

*Handwritten signature*

*Handwritten notes and stamps*

c. Machining Centre System

d. Adaptive Control System

10) Which machine tool reduces the number of set-ups in machining operation, time spent in setting machine tools and transportation between sections of machines?

a. Computer Numerical Control machine tool

b. Direct Numerical Control machine tool

c. Adaptive Control Systems

d. Machining centre

11. Which of the following code will give point to point movement?

a) G00

b) G01

c) G56

d) G94

12. Which of the following code will give linear interpolation movement?

a) G00

b) G01

c) G78

d) G65

13. Which of the following code will give circular interpolation in a clockwise direction?

a) G56

b) G01

c) G02

d) G47

14. Which of the following code will give circular interpolation in Counterclockwise direction?

a) G00

b) G56

c) G69

d) G03

15. Which the following code will produce dwell for a specified time?

a) G18

b) G65

c) G45

d) G04



*Handwritten signature in green ink.*

PRINCIPAL  
Nohru College of  
Engineering and Research Centre  
Panaji, Talukpanaji, Goa  
Pin - 556 037, India

16. Which of the following code is used to give input of cutter offset data?

- a) G30
- b) G20
- c) G10
- d) G04

17. Which of the following code is used to select x y plane in milling?

- a) G18
- b) G17
- c) G10
- d) G04

18. Which of the following code is used to select x z plane in milling?

- a) G18
- b) G17
- c) G10
- d) G04

19. Which of the following code is used to select y-z plane in milling?

- a) G32
- b) G00
- c) G02
- d) G19

20. Which of the following code will change specified input values in millimeters?

- a) G01
- b) G00
- c) G20

21. Which of the following code is used to return to a reference point?

- a) G23
- b) G28
- c) G14
- d) G19

22. Which of the following code is used in thread cutting in turning?

- a) G32
- b) G89

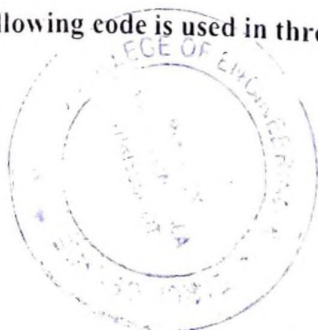

  
 PRINCIPAL  
 Nehru College of  
 Engineering and Research Centre  
 Windmill Road, Bangalore  
 Ph: 660 597, 660 598

- c) ~~G20~~
- d) G74

23. Which of the following code is used to cancel offset compensation for cutter radius?

- a) G40
- b) G02
- c) G42
- d) G00



24. Which of the following code is used to give cutter offset compensation, left of a part surface?

- a) G40
- b) G41
- c) G42
- d) G50



25. Which of the following code is used to give cutter offset compensation, right of a part surface?

- a) G00
- b) G41
- c) G42
- d) G91



  
PRINCIPAL  
College of  
and Research Centre  
Thiruvananthapuram Thiruvananthapuram  
Kerala



**NEHRU COLLEGE OF ENGINEERING AND RESEARCH CENTRE**

*(NAAC Accredited)*

**DEPARTMENT OF MECHANICAL ENGINEERING**

**END COURSE EXAMINATION**



Course: **CNC MACHINES, CONTROLS AND PART PROGRAMMING**

Date: 23<sup>rd</sup> February, 2016

Total Marks: **50**

Total Duration: **1 hour**

- Put a tick towards the right answer.
- If multiple options are chosen for a question it will not be considered for evaluation.
- Attend all the questions.
- There will be no negative marking.

Name: Akshay Santhosh

Register Number: NCAOEMF014

Semester/Year: 4/2<sup>nd</sup>

36/50

Each question carries 2 marks

1) Arrange the below operations in operator controlled machine tool in correct order.

(A) Operator (B) Process planning (C) Machine tool (D) Component drawing (E) Completed component

a. (A) – (D) – (B) – (C) – (E)

b. (D) – (B) – (C) – (A) – (E)

c. (B) – (D) – (C) – (A) – (E)

d. (D) – (B) – (A) – (C) – (E)

X

2) The device, fed to the control unit of NC machine tool which sends the position command signals to sideway transmission elements of the machine, is called as

a. controller

b. tape

c. feedback unit

d. none of the above

X

3) In NC (Numerical Control) machine tool, the position feedback package is connected between

a. control unit and programmer

b. programmer and machine tool

c. control unit and machine tool

d. programmer and process planning

X

4) Which of the following options is correct for the control unit and panel of NC (Numerical Control) and CNC (Computer Numerical Control) machine tools?

a. The control unit of NC machine tool works in ON-line mode and the control unit of CNC machine tool works in batch processing mode

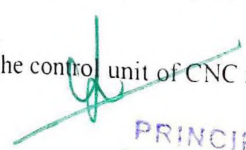
  
**PRINCIPAL**  
 Nehru College of  
 Engineering and Research Centre  
 Marol Nagar, Thiruvananthapuram, Kerala Dt.  
 PIN - 695 016

b. The control unit of NC machine tool works in batch processing mode and the control unit of CNC machine tool works in ON-line mode

c. The control units of both NC and CNC machines work in ON-line mode

d. The control units of both NC and CNC machines work in batch processing mode

**5) In CNC machine tool, the part program entered into the computer memory**

a. can be used only once

b. can be used again and again

c. can be used again but it has to be modified every time

d. cannot say



**6) Which of the following statements are correct for CNC machine tool?**

1. CNC control unit does not allow compensation for any changes in the dimensions of cutting tool

2. CNC machine tool are suitable for long run applications

3. It is possible to obtain information on machine utilization which is useful to management in CNC machine tool

4. CNC machine tool has greater flexibility

5. CNC machine can diagnose program and can detect the machine defects even before the part is produced

a. (1), (2) and (3)

b. (2), (4) and (5)

c. (3), (4) and (5)

d. (2), (3), (4) and (5)



**7) Several machine tools can be controlled by a central computer in**

a. NC (Numerical Control) machine tool

b. CNC (Computer Numerical Control) machine tool

c. DNC (Direct Numerical Control) machine tool

d. CCNC (Central-Computer Numerical Control) machine tool



**8) Part-programming mistakes can be avoided in**

a. NC (Numerical Control) machine tool

b. CNC (Computer Numerical Control) machine tool

c. Both a. and b.

d. None of the above



**9) The machine tool, in which calculation and setting of the operating conditions like depth of cut, feed, speed are done during the machining by the control system itself, is called**

a. Computer Numerical Control System

b. Direct Numerical Control System

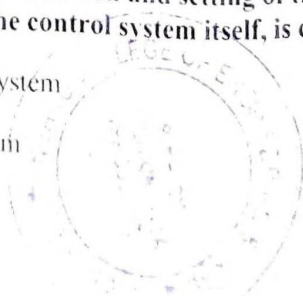

c. Machining Centre System

d. Adaptive Control System

10) Which machine tool reduces the number of set-ups in machining operation, time spent in setting machine tools and transportation between sections of machines?

a. Computer Numerical Control machine tool

b. Direct Numerical Control machine tool

c. Adaptive Control Systems

d. Machining centre

11. Which of the following code will give point to point movement?

a) G00

b) G01

c) G56

d) G94

12. Which of the following code will give linear interpolation movement?

a) G00

b) G01

c) G78

d) G65

13. Which of the following code will give circular interpolation in a clockwise direction?

a) G56

b) G01

c) G02

d) G47

14. Which of the following code will give circular interpolation in Counterclockwise direction?

a) G00

b) G56

c) G69

d) G03

15. Which the following code will produce dwell for a specified time?

a) G18

b) G65

c) G45

d) G04



*[Handwritten Signature]*

PRINCIPAL

Principal, College of  
Engineering and Technology  
[Address]

16. Which of the following code is used to give input of cutter offset data?

- a) G30
- b) G20
- c) G10
- d) G04

17. Which of the following code is used to select x y plane in milling?

- a) G18
- b) G17
- c) G10
- d) G04

18. Which of the following code is used to select x z plane in milling?

- a) G18
- b) G17
- c) G10
- d) G04

19. Which of the following code is used to select y-z plane in milling?

- a) G32
- b) G00
- c) G02
- d) G19

20. Which of the following code will change specified input values in millimeters?

- a) G01
- b) G00
- c) G20

21. Which of the following code is used to return to a reference point?

- a) G23
- b) G28
- c) G14
- d) G19

22. Which of the following code is used in thread cutting in turning?

- a) G32
- b) G89



*ch*

PRINCIPAL  
 Nehru College of  
 Engineering and Research Centre  
 Bangalore University, Bangalore

c) G20

d) G74

23. Which of the following code is used to cancel offset compensation for cutter radius?

a) G40

b) G02

c) G42

d) G00

24. Which of the following code is used to give cutter offset compensation, left of a part surface?

a) G40

b) G41

c) G42

d) G50

25. Which of the following code is used to give cutter offset compensation, right of a part surface?

a) G00

b) G41

c) G42

d) G91

  
PRINCIPAL  
Neeru College of  
Engineering and Research Centre  
11002, 11, K. V. M. M. Thiruvananthapuram, Thiruvananthapuram Dt  
Kerala



**NEHRU COLLEGE OF ENGINEERING AND RESEARCH CENTRE, PAMPADY, THIRISSUR**  
**DEPARTMENT OF MECHANICAL ENGINEERING**  
**END COURSE EXAM MARK STATEMENT**

YEAR 2015-16  
 COURSE **CNC MACHINES, CONTROLS AND PART PROGRAMMING**  
 FACULTY-IN-CHARGE **Mr. PRASHOB M A**

Sl. No	Reg No	Name	MARKS (50)
1	NCAOEME001	AADITH K JAYARAJ	26
2	NCAOEME002	ABEL ELIAS	28
3	NCAOEME125	ABHILITH A	42
4	NCAOEME003	ABHILASH C	26
5	NCAOEME004	ABHILASH P MOHAN	32
6	NCAOEME005	ACHUTH KAILAS E	32
7	NCAOEME006	ADARSH A	48
8	NCAOEME007	ADARSH CHANDRA	48
9	NCAOEME008	ADHARSH K T	46
10	NCAOEME009	ADITH VARMA M	34
11	NCAOEME010	AJAY SEKHAR	30
12	NCAOEME126	AJITH P BABU	42
13	NCAOEME011	AKHIL KRISHNAN M.A	42
14	NCAOEME012	AKSHAY MOHANDAS	44
15	NCAOEME013	AKSHAY P	38
16	NCAOEME014	AKSHAY SANTHOSH	36
17	NCAOEME072	AKSHAYDAS NP	28
18	NCAOEME016	AMAL SANKAR T S	48
19	NCAOEME017	AMEER SUHAIL	38
20	NCAOEME018	AMRITHESE M	34
21	NCAOEME019	ANEESH KRISHNAN P	42
22	NCAOEME020	ANSAR S	42
23	NCAOEME021	ANWAR P A	44
24	NCAOEME023	ARJUN A.S	38
25	NCAOEME133	ARJUNLAL A.C	34
26	NCAOEME024	ARSHAQ K S	36
27	NCAOEME025	ARUN GOPINATHAN K	40
28	NCAOEME026	ARUN K	46
29	NCAOEME027	ARUN S	42
30	NCAOEME029	ASHWIN NAIR	44
31	NCAOEME030	ASWAN KRISHNA R	38
32	NCAOEME032	ATHUL T.S	42
33	NCAOEME033	BARATH M	42
34	NCAOEME034	BIJU P.M	26
35	NCAOEME035	BIMAL BAIJU C	32
36	NCAOEME036	DEVNATH C.D	32
37	NCAOEME037	DHANEESH KRISHNAN	48
38	NCAOEME038	DILEEP M	48
39	NCAOEME039	GANESH S	30
40	NCAOEME040	GOKUL P MENON	42
41	NCAOEME132	JIBIN C.K	34
42	NCAOEME041	JISHNU MADHAVAN	36
43	NCAOEME042	JITHIN KRISHNA A.P	40
44	NCAOEME043	JITTO GEORGE	46
45	NCAOEME044	KINAYATH SACHIN MENON	42
46	NCAOEME046	KIRAN KRISHNA P.S	48
47	NCAOEME045	KIRANDAS PR	46
48	NCAOEME047	KISHAN S MOHAN	32
49	NCAOEME048	LINTO T PALAYOOR	32
50	NCAOEME127	MANOJ K P	42
51	NCAOEME049	MANSUR K M	44
52	NCAOEME050	MIDHUN A	38
53	NCAOEME051	MIDHUN M	42
54	NCAOEME052	MINHAJ P	42
55	NCAOEME053	MOHAMED SAFEER C	16
56	NCAOEME054	MOHAMMED NIBIL P.K	36
57	NCAOEME055	MOHAMMED RIFAD	26
58	NCAOEME056	MOHAMMED RISAL	40
59	NCAOEME057	MOHAMMED SALIH N.P	42
60	NCAOEME058	MOHAMMED SHIBIN P	34
61	NCAOEME063	NAIR VINAY SASIKUMAR	28
62	NCAOEME064	NAKUL A.R	48
63	NCAOEME065	NANDAGOPAL V V	38
64	NCAOEME066	NAVEEN S	34
65	NCAOEME067	NAZRUL AZLAM	42
66	NCAOEME068	NIBINLAL PT	42
67	NCAOEME069	NIDHIN MOHAN P	44
68	NCAOEME070	NIKHIL J	38
69	NCAOEME073	PRAKHIL P	34
70	NCAOEME074	RAHUL M	42
71	NCAOEME075	RAHUL MURALI P	44
72	NCAOEME077	RAKESH P.R	38
73	NCAOEME078	RAMACHANDRAN S	42
74	NCAOEME079	RAMDAS M	42
75	NCAOEME080	RAMSHEER P	42

Sl. No	Reg No	Name	MARKS (50)
76	NCAOEME081	RANJI R	28
77	NCAOEME082	RANJISH K	28
78	NCAOEME083	RIJAS S	30
79	NCAOEME084	ROHIT S THATTIL	48
80	NCAOEME085	ROSHIN K H	38
81	NCAOEME086	SAANU SADANAND	34
82	NCAOEME087	SACHINDEV V	42
83	NCAOEME088	SAJEEV A S	42
84	NCAOEME089	SAJITH S	38
85	NCAOEME090	SANDEEP KUMAR K P	42
86	NCAOEME091	SANEESH M	42
87	NCAOEME092	SANGEETH NARAYAN B	48
88	NCAOEME093	SANJAY C	38
89	NCAOEME095	SARATH ARAVIND S	36
90	NCAOEME096	SARATH C	32
91	NCAOEME097	SATHEESH R	36
92	NCAOEME098	SHARATH JAYAKRISHNAN	30
93	NCAOEME128	SHOYAB MOHAMED SHELLY	28
94	NCAOEME099	SHRAVAN K	48
95	NCAOEME100	SIDDHARTH G S	10
96	NCAOEME101	SOORAJ BHASKARAN	4
97	NCAOEME102	SOORYAJITH	6
98	NCAOEME129	SREEJITH K	12
99	NCAOEME103	SREEJITH K P	8
100	NCAOEME104	SREEJITH S DEVAN	12
101	NCAOEME105	SREERAG M	26
102	NCAOEME106	SREERAG S	28
103	NCAOEME108	SUBIN D STEPHEN	30
104	NCAOEME109	SUHAIL K.M	34
105	NCAOEME110	SYAMJITH K	30
106	NCAOEME131	TINUKRISHNAN P	46
107	NCAOEME121	VARUN SWAMY V	34
108	NCAOEME112	VIJESH M V	30
109	NCAOEME130	VINEETH VARIYAR	42
110	NCAOEME113	VIPUL VISWANATHAN	42
111	NCAOEME114	VISAL P	44
112	NCAOEME115	VISHNU BHASKAR R	38
113	NCAOEME116	VISHNU M	48
114	NCAOEME117	VISHNU SHANKAR	32
115	NCAOEME118	VISHNU T.G	36
116	NCAOEME119	VIVEK SANKAR P	34
117	NCAOEME120	VIVEK V NAIR	38
118	NCAOEME122	VYSHAK K	30
119	NCAOEME123	YADHUKRISHNA A	36
120	NCAOEME124	YADUKRISHNAN V	42
121	NCE15ME001	ABDUL LATHEEF A	44
122	NCE15ME002	ABDULLA S	48
123	NCE15ME003	ABEJITH D	48
124	NCE15ME005	ABHILITH V NAIR	26
125	NCE15ME006	ABHISHEK SUNIL	10
126	NCE15ME008	ADVAIDH H	38
127	NCE15ME009	AJITH C	42
128	NCE15ME010	AJITH K A	44
129	NCE15ME012	AJMAL P	38
130	NCE15ME024	ANIRUDH S NAIR	36
131	NCE15ME025	ARJUN PURATHENDERRI	34
132	NCE15ME028	ASRITH K V	38
133	NCE15ME030	ATHUL DAS C H	46
134	NCE15ME065	MELVIN JOHNSON	32
135	NCE15ME066	MITHUN GOPINATH	42
136	NCE15ME067	MOHAMED JASIL C	44
137	NCE15ME068	MOHAMMED SAFARULLA	38
138	NCE15ME069	MUHAMMED KUNHI M P	42
139	NCE15ME070	NAJMAL K JAMAL	42
140	NCE15ME071	NANDAGOPAN K S	42
141	NCE15ME073	NIJIL C R	36
142	NCE15ME074	NITHIN A M	36
143	NCE15ME075	NITHIN K P	28
144	NCE15ME076	NITHIN R K	40
145	NCE15ME079	NOUSHAD C N	34
146	NCE15ME081	PAJITH T	42
147	NCE15ME084	RAMSHID S M	42
148	NCE15ME085	RENJITH N P	44
149	NCE15ME084	RAMSHID S M	38
148	NCE15ME085	RENJITH N P	34

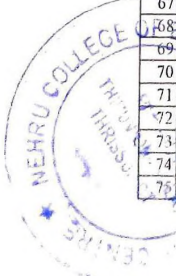

PROGRAM COORDINATOR

PRINCIPAL

Nehru College of  
 Engineering and Research Centre  
 Pampady, Thiruvalla, Thiruvananthapuram



# Certificate



**AKSHAY SANTHOSH**

had successfully completed **CNC MACHINES, CONTROL AND PART PROGRAMMING** during 2015-2016 conducted by **Department of Mechanical Engineering** at, **Nehru College of Engineering and Research Centre Pampady, Thrissur.**

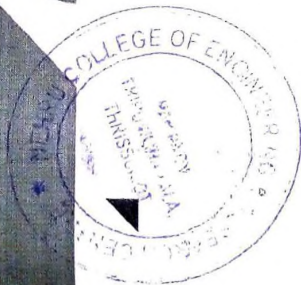

**PROGRAM  
CO-ORDINATOR**

**HEAD OF  
DEPARTMENT**

**PRINCIPAL**  
Nehru College of  
Engineering and Research  
Centre Pampady, Thrissur



# Certificate



**ASHWIN NAIR**

had successfully completed **CNC MACHINES, CONTROL AND PART PROGRAMMING** during 2015-2016 conducted by **Department of Mechanical Engineering** at, **Nehru College of Engineering and Research Centre Pampady, Thrissur.**

PROGRAM  
CO-ORDINATOR

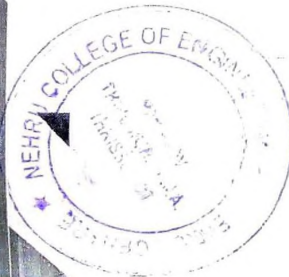

HEAD OF  
DEPARTMENT

PRINCIPAL  
Nehru College of  
Engineering and Research Centre  
Pampady, Thrissur  
Pin - 680 511



# Certificate



**VISHNU M**

had successfully completed **CNC MACHINES, CONTROL AND PART PROGRAMMING** during 2015-2016 conducted by **Department of Mechanical Engineering** at, **Nehru College of Engineering and Research Centre Pampady, Thrissur.**

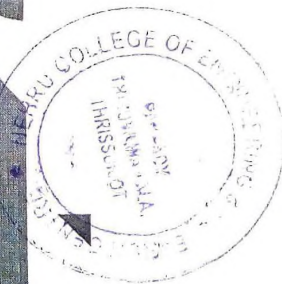

**PROGRAM  
CO-ORDINATOR**

**HEAD OF  
DEPARTMENT**

**PRINCIPAL**  
Nehru College of  
Engineering and Research  
Centre Pampady, Thrissur



**NEHRU COLLEGE OF ENGINEERING AND RESEARCH CENTRE**  
**(NAAC Accredited)**

(Approved by AICTE, Affiliated to APJ Abdul Kalam Technological University, Kerala)



# **Mechatronics Engineering**



# **NEHRU COLLEGE OF ENGINEERING AND RESEARCH CENTRE**



*(NAAC Accredited)*

*(Approved by AICTE & Affiliated to University of Calicut  
and Kerala Technological University)*

## **DEPARTMENT OF MECHANICAL ENGINEERING**

The Department of Mechanical Engineering is planning to conduct a 30 hour certification course scheduled during the months of January and February of this academic year 2015 - 2016. The course is intended to be beneficial for students in their academics as well as professional life and therefore is offered to all B.Tech Mechanical Engineering students. All the students are here by directed to enroll in the course mandatorily.

**COURSE NAME: "CNC MACHINES, CONTROLS AND PART PROGRAMMING"**

**PROGRAM CO-ORDINATOR: Mr. PRASHOB M.A**

**Assistant Professor**

**Mechanical Department**

**DATE OF COMMENCEMENT: 2nd February 2016**

**DURATION: 30 Hours**



  
**PRINCIPAL**  
Nehru College of  
Engineering and Research Centre  
Thiruvady Thiruvizhamala, Thiruvady Dt  
Pin - 686597 Kerala



**NEHRU COLLEGE OF ENGINEERING AND RESEARCH CENTRE**  
**(NAAC Accredited)**  
(Approved by AICTE, Affiliated to University of Calicut & APJ Abdul Kalam Technological University, Kerala)



**ADMISSION TO CERTIFICATION COURSE (2015-2016)**

Applications are invited for admission for the Certification Course 'SIGNALS AND SYSTEMS' offered by the Department of Mechatronics Engineering, Nehru college of Engineering and Research Centre, Pampady, Thrissur.

**Eligibility criteria**

All UG engineering students of MTR Department are eligible

**Timing:**

1 hour per day from 4.00pm to 5.00pm for 30 hours of the course. Saturday and Sunday may be used at the discretion of the department.

**Attendance**

A minimum of 75% attendance is required for writing the examination.

**Important Dates**

Commencement of classes: 24-08-2015

Examination Date: 13-11-2015

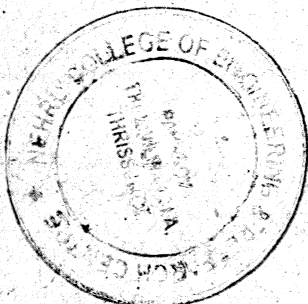

HOD

**PRINCIPAL**  
Nehru College of  
Engineering and Research Centre  
Pampady, Thiruvilwamala, Thrissur Dt  
Pin - 680 597 Kerala.

FROM

MR. MIDHUNRAJ P K,

ASSISTANT PROFESSOR

MTR DEPARTMENT, NCERC PAMPADY

TO

HEAD OF THE DEPARTMENT

MTR DEPARTMENT

NCERC PAMPADY

SUBJECT: Requisition for conducting Certification Course on "SIGNALS AND SYSTEMS"

Respected Sir,

As the Assistant Professor of Mechatronics Engineering, I would like to request your support and permission to conduct a Certification Course on "SIGNALS AND SYSTEMS" from 24-08-2015. It will be a 30 hour course scheduled for July to October of this academic year 2015-2016. It is therefore important for students to have a deep understanding of upcoming methodologies to enhance knowledge dissemination to students for doing projects.

All UG Engineering students of MTR Department are eligible for this course.

Sincerely,

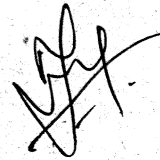

PRINCIPAL

Nehru College of  
Engineering and Research Centre  
Pampady Thiruvilwamala, Thrissur U  
Pin 680 597 Kerala

PLACE: Pampady  
DATE: 02/07/2015

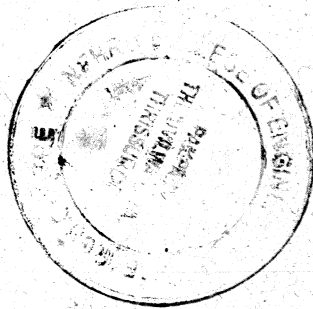

FROM

MR. MIDHUNRAJ P K

ASSISTANT PROFESSOR

MTR DEPARTMENT, NCERC PAMPADY

*Forwarded to Principal*



TO

THE PRINCIPAL,

NCERC PAMPADY

Through HOD

Respected Sir,

SUBJECT: Requisition for conducting Certification Course on "SIGNALS AND SYSTEMS" Reg.

Students need a deep understanding of upcoming methodologies to enhance knowledge dissemination for doing projects. Signals and system is necessary for understanding the concepts of digital image processing and digital signal processing, so Mechatronics Engineering department would like to conduct a Certification Course on "SIGNALS AND SYSTEMS" from 24-08-2015. It will be a 30 hour course scheduled for July to October of this academic year 2015-2016. Kindly request you to give the permission for the same.

All UG Engineering students of MTR Department are eligible for this course.

Sincerely,



PLACE: *Pampady*

DATE: *3/8/15*

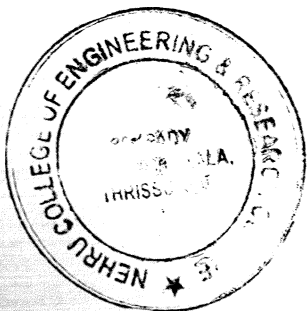

**PRINCIPAL**  
Nehru College of  
Engineering and Research Centre  
Pampady, Thiruvilwamala, Thiruvananthapuram Dt

# NEHRU COLLEGE OF ENGINEERING AND RESEARCH CENTRE

(ACCREDITED BY NAAC)

PAMPADY, THIRUVILWAMALA, THRISSUR DIST.

## MINUTES OF DEPARTMENT ADVISORY COMMITTEE MEETING HELD ON 31/12/2015

A meeting of the Department Advisory Committee (DAC) was held on 31<sup>st</sup> December 2015 at 10:00 AM in the chamber of HoD, MTR department.

The following members were present:

1. Prof. Radhakrishnan -HoD,MTR Dept.
2. Mr. Niveth L-Assistant Professor, MTR Dept.
3. Mr. Midhunraj P K-Assistant Professor, MTR Dept.
4. Ms. Ranjith P N-Assistant Professor, MTR Dept.
5. Mr. Manu R Krishnan-Assistant Professor, MTR Dept.

The following decisions were taken:

1. It was decided to conduct a certificate course on "SIGNALS AND SYSTEMS" during the second and fourth Saturdays of the academic year 2015-16 for a period of 30 hours.
2. The course will enhance the knowledge level of students in the field of signals and systems.
3. It was decided to provide the course for the UG students of Mechatronics Engg. Department.
4. Also, it was decided to ensure compulsory attendance and staff advisors should monitor the same.

The meeting came to an end at 10:40 AM.

  
HoD



PRINCIPAL  
Nehru College of  
Engineering and Research Centre  
Pampady Thiruvilwamala Thrissur Dt  
Pin 680-597 Kerala

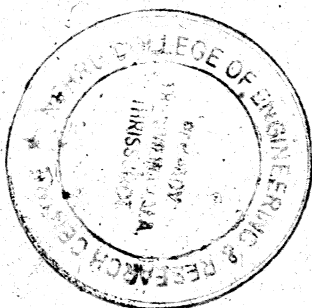



**NEHRU COLLEGE OF ENGINEERING AND RESEARCH CENTRE**  
(NAAC Accredited)

(Approved by AICTE, Affiliated to APJ Abdul Kalam Technological University, Kerala)

**ADD ON COURSE SYLLABUS AND SCHEDULE**



**SIGNALS AND SYSTEMS**

**Module-1 Introduction and Classification of signals**

Introduction and Classification of signals: Definition of signal and systems, communication and control systems as examples. Sampling of analog signals, Continuous time and discrete time signal, Classification of signals as even, odd, periodic and non-periodic, deterministic and non-deterministic, energy and power. Elementary signals/Functions: exponential, sine, impulse, step and its properties, ramp, rectangular, triangular, signum, sync functions

**Module-2 Time domain representation of LTI System**

Time domain representation of LTI System: System modeling: Input-output relation, definition of impulse response, convolution sum, convolution integral, computation of convolution integral and convolution sum using graphical method for unit step to unit step, unit step to exponential, exponential to exponential, unit step to rectangular and rectangular to rectangular only. Properties of convolution.

**Module-3 Fourier Representation of Periodic Signals**

System interconnection, system properties in terms of impulse response, step response in terms of impulse response. Fourier Representation of Periodic Signals: Introduction to CTFS and DTFS, definition, properties (No derivation) and basic problems (inverse Fourier series is excluded).

**Module-4 Fourier Representation of aperiodic Signals**

Fourier Representation of aperiodic Signals: FT representation of aperiodic CT signals - FT, definition, FT of standard CT signals, Properties and their significance. FT representation of aperiodic discrete signals DTFT, definition, DTFT of standard discrete signals, Properties and their significance, Impulse sampling and reconstruction: Sampling theorem (only statement) and reconstruction of signals. Z-Transforms: Introduction, the Z-transform, properties of the Region of convergence, Properties of the Z-Transform, Inversion of the Z-Transform, Transform analysis of LTI systems.

**COURSE SCHEDULE**

Commencement of classes: 24-08-2015

Examination Date: 13-11-2015

  
PROGRAM COORDINATOR

  
HOD

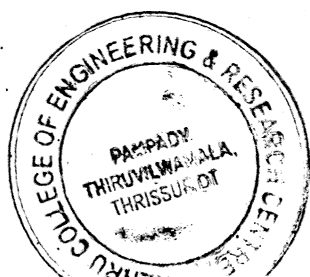

  
PRINCIPAL  
Nehru College of  
Engineering and Research Centre  
Pampady, Thiruvilwamala, Thrissur Dt.  
Pin 680 597 Kerala

**NEHRU COLLEGE OF ENGINEERING & RESEARCH CENTRE**  
Pampady, Thiruvilwamala, Thrissur Dt.  
**DEPARTMENT OF MECHATRONICS ENGINEERING**  
**SIGNALS AND SYSTEMS**  
**Attendance Sheet**

SL. NO.	REG. NO.	NAME OF STUDENT	24/8/15	25/8/15	1/9/15	2/9/15	8/9/15	10/9/15	11/9/15	14/9/15	17/9/15	19/9/15
1	NCANEMT001	ABHIJITH C	✓	✓	✓	✓	✓	a	✓	✓	a	✓
2	NCANEMT004	AKSHAY CHANDRAN	✓	✓	✓	✓	✓	✓	✓	✓	✓	✓
3	NCANEMT007	ALTHAF MOHAMMED M	✓	✓	✓	✓	✓	✓	✓	✓	✓	✓
4	NCANEMT011	ARAVIND P	✓	✓	✓	✓	✓	✓	✓	✓	✓	✓
5	NCANEMT012	ARJUNGOPI	✓	✓	✓	✓	✓	✓	✓	✓	✓	✓
6	NCANEMT013	ARJUN K G	✓	✓	✓	✓	✓	✓	✓	✓	✓	✓
7	NCANEMT016	ARJUN VIJAY	✓	✓	✓	✓	✓	✓	✓	✓	✓	✓
8	NCANEMT019	ATHUL AJITH K	✓	✓	✓	✓	✓	✓	✓	✓	✓	✓
9	NCANEMT021	AVINASH SEN	✓	✓	✓	✓	✓	✓	✓	✓	✓	✓
10	NCANEMT024	EBIN SUNNY	✓	✓	✓	✓	✓	✓	✓	✓	✓	✓
11	NCANEMT025	EMIL TOM	✓	✓	✓	✓	✓	✓	✓	✓	✓	✓
12	NCANEMT026	FREDIN V JOSE	✓	✓	✓	✓	✓	✓	✓	✓	✓	✓
13	NCANEMT029	JERIN JOSE	✓	✓	✓	✓	✓	✓	✓	✓	✓	✓
14	NCANEMT030	JITHESH V K	✓	✓	✓	✓	✓	✓	✓	✓	✓	✓
15	NCANEMT034	MOHAMMED MISHAL K	✓	✓	✓	✓	✓	✓	✓	✓	✓	✓
16	NCANEMT037	NAVEEN V	✓	✓	✓	✓	✓	✓	✓	✓	✓	✓
17	NCANEMT038	PRAVEEN A S	✓	✓	✓	✓	✓	✓	✓	✓	✓	✓
18	NCANEMT041	RIBIN MATHEW	✓	✓	✓	✓	✓	✓	✓	✓	✓	✓
19	NCANEMT044	SAYOOJ T K	✓	✓	✓	✓	✓	✓	✓	✓	✓	✓
20	NCANEMT046	SHYAMAPRASAD O K	✓	✓	✓	✓	✓	✓	✓	✓	✓	✓
21	NCANEMT047	SIDDARTH A T	✓	✓	✓	✓	✓	✓	✓	✓	✓	✓
22	NCANEMT048	SREEJITH P G	✓	✓	✓	✓	✓	✓	✓	✓	✓	✓
23	NCANEMT049	SRUTHY S NAIR	✓	✓	✓	✓	✓	✓	✓	✓	✓	✓
24	NCANEMT054	VARSHA C K	✓	✓	✓	✓	✓	✓	✓	✓	✓	✓
25	NCANEMT052	JASEEL P	✓	✓	✓	✓	✓	✓	✓	✓	✓	✓
26	NCANEMT053	SOUMYA A K	✓	✓	✓	✓	✓	✓	✓	✓	✓	✓
27	NCANEMT001	AAZTLEKHAN N	✓	✓	✓	✓	✓	✓	✓	✓	✓	✓

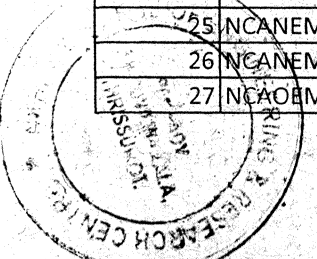

*[Handwritten Signature]*

PRINCIPAL  
Nehru College of  
Engineering and Research Centre

28	NCAOEMT002	ABDULLA NAJID C P	a	✓	✓	✓	✓	✓	a	✓	a	✓
29	NCAOEMT003	ABHIJITH JOHN	✓	✓	a	✓	✓	a	✓	✓	✓	✓
30	NCAOEMT004	ABY POIUSON	✓	✓	✓	a	✓	✓	✓	a	✓	a

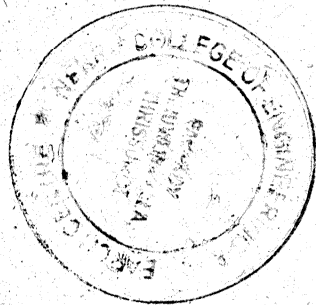

*[Handwritten signature]*

**PRINCIPAL**  
 Nehru College of  
 Engineering and Research Centre  
 Thiruvananthapuram, Thiruvananthapuram, Kerala



PROGRAM COORDINATOR

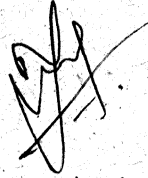

HOD

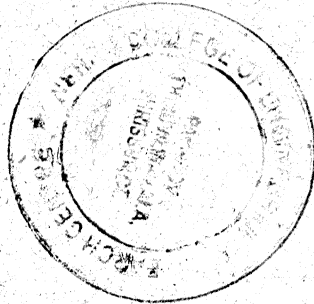
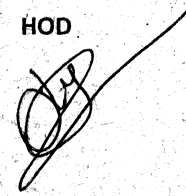

PRINCIPAL

Nehru College of  
Engineering and Research Centre  
Pampady Thiruvilwamala Thiruvananthapuram Dt  
Pin - 690 597 Kerala

**NEHRU COLLEGE OF ENGINEERING & RESEARCH CENTRE**

Pampady, Thiruvilwamala, Thrissur Dt.

**DEPARTMENT OF MECHATRONICS ENGINEERING**

**SIGNALS AND SYSTEMS**

**Attendance Sheet**

SL. NO.	REG. NO.	NAME OF STUDENT	25/9/15	26/9/15	29/9/15	30/9/15	5/10/15	6/10/15	7/10/15	10/10/15	12/10/15	14/10/15
1	NCANEMT001	ABHIJITH C	✓	✓	a	✓	✓	✓	✓	✓	✓	✓
2	NCANEMT004	AKSHAY CHANDRAN	✓	a	✓	✓	✓	✓	✓	✓	✓	✓
3	NCANEMT007	ALTHAF MOHAMMED M	✓	✓	✓	✓	✓	✓	✓	✓	✓	✓
4	NCANEMT011	ARAVIND P	✓	✓	✓	✓	✓	✓	✓	✓	✓	✓
5	NCANEMT012	ARJUNGOPI	✓	✓	✓	✓	✓	✓	✓	✓	✓	✓
6	NCANEMT013	ARJUN K G	✓	✓	✓	✓	✓	✓	✓	✓	✓	✓
7	NCANEMT016	ARJUN VIJAY	✓	✓	✓	✓	✓	✓	✓	✓	✓	✓
8	NCANEMT019	ATHUL AJITH K	✓	✓	✓	✓	✓	✓	✓	✓	✓	✓
9	NCANEMT021	AVINASH SEN	✓	✓	✓	a	✓	✓	✓	✓	✓	✓
10	NCANEMT024	EBIN SUNNY	✓	✓	✓	✓	✓	✓	✓	✓	✓	✓
11	NCANEMT025	EMIL TOM	✓	✓	✓	✓	✓	✓	✓	✓	✓	✓
12	NCANEMT026	FREDIN V JOSE	✓	✓	✓	✓	✓	✓	✓	✓	✓	✓
13	NCANEMT029	JERIN JOSE	✓	✓	✓	✓	✓	✓	✓	✓	✓	✓
14	NCANEMT030	JITHESH V K	✓	✓	✓	✓	✓	✓	✓	✓	✓	✓
15	NCANEMT034	MOHAMMED MISHAL K	✓	✓	✓	✓	✓	✓	✓	✓	✓	✓
16	NCANEMT037	NAVEEN V	✓	✓	✓	✓	✓	✓	✓	✓	✓	✓
17	NCANEMT038	PRAVEEN A S	✓	✓	✓	✓	✓	✓	✓	✓	✓	✓
18	NCANEMT041	RIBIN MATHEW	✓	✓	✓	✓	✓	✓	✓	✓	✓	✓
19	NCANEMT044	SAYOOJ T K	✓	✓	✓	✓	✓	✓	✓	✓	✓	✓
20	NCANEMT046	SHYAMAPRASAD O K	✓	✓	✓	✓	✓	✓	✓	✓	✓	✓
21	NCANEMT047	SIDDARTH A T	✓	✓	✓	✓	✓	✓	✓	✓	✓	✓
22	NCANEMT048	SREEJITH P G	✓	✓	✓	✓	✓	✓	✓	✓	✓	✓
23	NCANEMT049	SRUTHY S NAIR	✓	✓	✓	✓	✓	✓	✓	✓	✓	✓
24	NCANEMT054	VARSHA C K	✓	✓	✓	✓	✓	✓	✓	✓	✓	✓
25	NCANEMT052	JASEEL P	✓	✓	✓	✓	✓	✓	✓	✓	✓	✓
26	NCANEMT053	SOUMYA A K	✓	✓	✓	✓	✓	✓	✓	✓	✓	✓
27	NCANEMT001	AAZTLEKHAN N	✓	✓	✓	✓	✓	✓	✓	✓	✓	✓

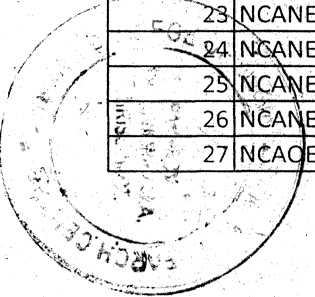

**PRINCIPAL**  
 Nehru College of  
 Engineering and Research Centre  
 Pampady Thiruvilwamala Thrissur Dt.

28	NCAOEMT002	ABDULLA NAJID C P	✓	a	✓	✓	✓	✓	✓	✓	a	✓
29	NCAOEMT003	ABHIJITH JOHN	✓	✓	a	✓	✓	✓	a	✓	✓	✓
30	NCAOEMT004	ABY POIUSON	✓	✓	✓	✓	a	✓	✓	✓	✓	a

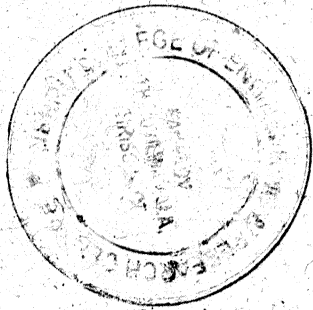

*[Handwritten Signature]*

**PRINCIPAL**  
 Nehru College of  
 Engineering and Research Centre  
 Panpady Thiruvilwamala, Thrissur Dt  
 Pin - 680 597, Kerala

31	NCAOEMT005	ADARSH MOHAN	/	/	/	/	/	/	/	/	/	/	/
32	NCAOEMT006	AISWARYA UNNI	/	/	/	/	/	/	/	/	/	/	/
33	NCAOEMT014	ANANDHU K V	/	/	/	/	/	/	/	/	/	/	/
34	NCAOEMT015	ANANTHU K S	/	/	/	/	/	/	/	/	/	/	/
35	NCAOEMT018	ARJUN	/	/	/	/	/	/	/	/	/	/	/
36	NCAOEMT020	ASHIK HAMEED SHA A P	/	/	/	/	/	/	/	/	/	/	/
37	NCAOEMT023	DERVISH HUSSAIN V	/	/	/	/	/	/	/	/	/	/	/
38	NCAOEMT024	EDWIN JOHNY	/	/	/	/	/	/	/	/	/	/	/
39	NCAOEMT029	GOPIKA M S	/	/	/	/	/	/	/	/	/	/	/
40	NCAOEMT030	GOVIND K	/	/	/	/	/	/	/	/	/	/	/
41	NCAOEMT035	JERIN T SUNNY	/	/	/	/	/	/	/	/	/	/	/
42	NCAOEMT036	JESEERA V P	/	/	/	/	/	/	/	/	/	/	/
43	NCAOEMT037	JINO G THOMAS	/	/	/	/	/	/	/	/	/	/	/
44	NCAOEMT043	MOYALAN JINTO JOSAN	/	/	/	/	/	/	/	/	/	/	/
45	NCAOEMT051	SARANG P	/	/	/	/	/	/	/	/	/	/	/
46	NCAOEMT052	SAWAD K J	/	/	/	/	/	/	/	/	/	/	/
47	NCAOEMT053	SETHUMADHAVAN K	/	/	/	/	/	/	/	/	/	/	/
48	NCAOEMT057	THAHA MOHAMMED TM	/	/	/	/	/	/	/	/	/	/	/
49	NCAOEMT058	VISHNU K ANAND	/	/	/	/	/	/	/	/	/	/	/
50	NCE15MC003	ADITHYA SURESH	/	/	/	/	/	/	/	/	/	/	/
51	NCE15MC004	ADITHYA MOHAN	/	/	/	/	/	/	/	/	/	/	/
52	NCE15MC008	AKSHAYLAL M R	/	/	/	/	/	/	/	/	/	/	/
53	NCE15MC013	ANUPAMA R NATH	/	/	/	/	/	/	/	/	/	/	/
54	NCE15MC014	ARJUN S	/	/	/	/	/	/	/	/	/	/	/
55	NCE15MC015	ATHIRA MENON	/	/	/	/	/	/	/	/	/	/	/
56	NCE15MC021	DEEPAK SUNIL	/	/	/	/	/	/	/	/	/	/	/
57	NCE15MC022	DEEPU VINIL	/	/	/	/	/	/	/	/	/	/	/
58	NCE15MC023	GOVIND K A	/	/	/	/	/	/	/	/	/	/	/
59	NCE15MC025	JEFINA TERESA JOHNSON	/	/	/	/	/	/	/	/	/	/	/
60	NCE15MC026	JEROM MATHEW PAUL	/	/	/	/	/	/	/	/	/	/	/
61	NCE15MC030	JOVIN DAVIS T	/	/	/	/	/	/	/	/	/	/	/
62	NCE15MC031	JUBY ELIZABETH JOHN	/	/	/	/	/	/	/	/	/	/	/
63	NCE15MC032	JUSTIN JOSE	/	/	/	/	/	/	/	/	/	/	/
64	NCE15MC036	MOHAMMED HANI SHERIF	/	/	/	/	/	/	/	/	/	/	/
65	NCE15MC037	MOHAMED JUNAID M C	/	/	/	/	/	/	/	/	/	/	/
66	NCE15MC043	NIRMAL C RAVINDRAN	/	/	/	/	/	/	/	/	/	/	/

  
**PRINCIPAL**  
 Nehru College of  
 Engineering and Research Centre  
 Panpady Thiruvilwamala, Thiruv. Dt

PROGRAM COORDINATOR



HOD

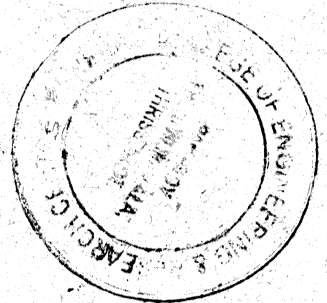
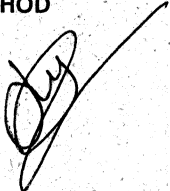

**PRINCIPAL**  
Nehru College of  
Engineering and Research Center  
Pampady Thiruvilwamala, Thrissur  
Pin: 686 501, Kerala

**NEHRU COLLEGE OF ENGINEERING & RESEARCH CENTRE**  
**Pampady, Thiruvilwamala, Thrissur Dt.**  
**DEPARTMENT OF MECHATRONICS ENGINEERING**  
**SIGNALS AND SYSTEMS**  
**Attendance Sheet**

SL. NO.	REG. NO.	NAME OF STUDENT	16/10/15	17/10/15	19/10/15	26/10/15	27/10/15	29/10/15	30/10/15	31/10/15	2/11/15	7/11/15
1	NCANEMT001	ABHIJITH C	✓	✓	✓	✓	a	✓	✓	a	✓	✓
2	NCANEMT004	AKSHAY CHANDRAN	✓	a	✓	✓	a	✓	a	a	✓	✓
3	NCANEMT007	ALTHAF MOHAMMED M	✓	✓	✓	✓	✓	a	✓	✓	✓	✓
4	NCANEMT011	ARAVIND P	✓	✓	✓	✓	✓	✓	✓	✓	✓	✓
5	NCANEMT012	ARJUNGOPI	✓	✓	✓	✓	✓	✓	✓	a	✓	✓
6	NCANEMT013	ARJUN K G	✓	✓	✓	✓	✓	✓	✓	✓	✓	✓
7	NCANEMT016	ARJUN VIJAY	✓	✓	✓	✓	✓	✓	✓	✓	✓	✓
8	NCANEMT019	ATHUL AJITH K	✓	✓	✓	✓	✓	✓	✓	✓	✓	✓
9	NCANEMT021	AVINASH SEN	✓	✓	✓	✓	✓	✓	✓	✓	✓	✓
10	NCANEMT024	EBIN SUNNY	✓	✓	✓	✓	✓	✓	✓	✓	✓	✓
11	NCANEMT025	EMIL TOM	✓	✓	✓	✓	✓	✓	✓	✓	✓	✓
12	NCANEMT026	FREDIN V JOSE	✓	✓	✓	✓	✓	✓	✓	✓	✓	✓
13	NCANEMT029	JERIN JOSE	✓	✓	✓	✓	✓	✓	✓	✓	✓	✓
14	NCANEMT030	JITHESH V K	✓	✓	✓	✓	✓	✓	✓	✓	✓	✓
15	NCANEMT034	MOHAMMED MISHAL K	✓	✓	✓	✓	✓	✓	✓	✓	✓	✓
16	NCANEMT037	NAVEEN V	✓	✓	✓	✓	✓	✓	✓	✓	✓	✓
17	NCANEMT038	PRAVEEN A S	✓	✓	✓	✓	✓	✓	✓	✓	✓	✓
18	NCANEMT041	RIBIN MATHEW	✓	✓	✓	✓	✓	✓	✓	✓	✓	✓
19	NCANEMT044	SAYOOJ T K	✓	✓	✓	✓	✓	✓	✓	✓	✓	✓
20	NCANEMT046	SHYAMAPRASAD O K	✓	✓	✓	✓	✓	✓	✓	✓	✓	✓
21	NCANEMT047	SIDDARTH A T	✓	✓	✓	✓	✓	✓	✓	✓	✓	✓
22	NCANEMT048	SREEJITH P G	✓	✓	✓	✓	✓	✓	✓	✓	✓	✓
23	NCANEMT049	SRUTHY S NAIR	✓	✓	✓	✓	✓	✓	✓	✓	✓	✓
24	NCANEMT054	VARSHA C K	✓	✓	✓	✓	✓	✓	✓	✓	✓	✓
25	NCANEMT052	JASEEL P	✓	✓	✓	✓	✓	✓	✓	✓	✓	✓
26	NCANEMT053	SOUMYA A K	✓	✓	✓	✓	✓	✓	✓	✓	✓	✓
27	NCANEMT001	AAZTLEKHAN N	✓	✓	✓	✓	✓	✓	✓	✓	✓	✓

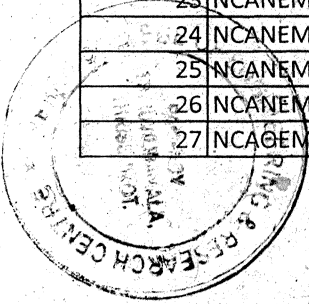

*(Handwritten signature)*

**PRINCIPAL**  
 Nehru College of  
 Engineering and Research Centre  
 Pampady Thiruvilwamala, Thrissur Dt.  
 Pin 680 597 Kerala

28	NCAOEMT002	ABDULLA NAJID C P	a	✓	✓	✓	✓	✓	✓	✓	a	✓	✓
29	NCAOEMT003	ABHIJITH JOHN	✓	a	✓	✓	✓	✓	a	✓	✓	✓	✓
30	NCAOEMT004	ABY POIUSON	✓	✓	✓	✓	✓	a	✓	✓	✓	✓	a

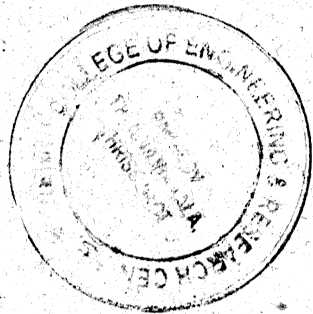

  
**PRINCIPAL**  
 Nehru College of  
 Engineering and Research Centre  
 Thiruvananthapuram

31	NCAOEMT005	ADARSH MOHAN	/	/	/	/	/	/	/	/	/	/	/
32	NCAOEMT006	AISWARYA UNNI	/	/	/	/	/	/	/	/	/	/	/
33	NCAOEMT014	ANANDHU K V	/	/	/	/	/	/	/	/	/	/	/
34	NCAOEMT015	ANANTHU K S	/	/	/	/	/	/	/	/	/	/	/
35	NCAOEMT018	ARJUN	/	/	/	/	/	/	/	/	/	/	/
36	NCAOEMT020	ASHIK HAMEED SHA A P	/	/	/	/	/	/	/	/	/	/	/
37	NCAOEMT023	DERVISH HUSSAIN V	/	/	/	/	/	/	/	/	/	/	/
38	NCAOEMT024	EDWIN JOHNY	/	/	/	/	/	/	/	/	/	/	/
39	NCAOEMT029	GOPIKA M S	/	/	/	/	/	/	/	/	/	/	/
40	NCAOEMT030	GOVIND K	/	/	/	/	/	/	/	/	/	/	/
41	NCAOEMT035	JERIN T SUNNY	/	/	/	/	/	/	/	/	/	/	/
42	NCAOEMT036	JESEERA V P	/	/	/	/	/	/	/	/	/	/	/
43	NCAOEMT037	JINO G THOMAS	/	/	/	/	/	/	/	/	/	/	/
44	NCAOEMT043	MOYALAN JINTO JOSAN	/	/	/	/	/	/	/	/	/	/	/
45	NCAOEMT051	SARANG P	/	/	/	/	/	/	/	/	/	/	/
46	NCAOEMT052	SAWAD K J	/	/	/	/	/	/	/	/	/	/	/
47	NCAOEMT053	SETHUMADHAVAN K	/	/	/	/	/	/	/	/	/	/	/
48	NCAOEMT057	THAHA MOHAMMED TM	/	/	/	/	/	/	/	/	/	/	/
49	NCAOEMT058	VISHNU K ANAND	/	/	/	/	/	/	/	/	/	/	/
50	NCE15MC003	ADITHYA SURESH	/	/	/	/	/	/	/	/	/	/	/
51	NCE15MC004	ADITHYA MOHAN	/	/	/	/	/	/	/	/	/	/	/
52	NCE15MC008	AKSHAYLAL M R	/	/	/	/	/	/	/	/	/	/	/
53	NCE15MC013	ANUPAMA R NATH	/	/	/	/	/	/	/	/	/	/	/
54	NCE15MC014	ARJUN S	/	/	/	/	/	/	/	/	/	/	/
55	NCE15MC015	ATHIRA MENON	/	/	/	/	/	/	/	/	/	/	/
56	NCE15MC021	DEEPAK SUNIL	/	/	/	/	/	/	/	/	/	/	/
57	NCE15MC022	DEEPU VINIL	/	/	/	/	/	/	/	/	/	/	/
58	NCE15MC023	GOVIND K A	/	/	/	/	/	/	/	/	/	/	/
59	NCE15MC025	JEFINA TERESA JOHNSON	/	/	/	/	/	/	/	/	/	/	/
60	NCE15MC026	JEROM MATHEW PAUL	/	/	/	/	/	/	/	/	/	/	/
61	NCE15MC030	JOVIN DAVIS T	/	/	/	/	/	/	/	/	/	/	/
62	NCE15MC031	JUBY ELIZEBETH JOHN	/	/	/	/	/	/	/	/	/	/	/
63	NCE15MC032	JUSTIN JOSE	/	/	/	/	/	/	/	/	/	/	/
64	NCE15MC036	MOHAMMED HANI SHERIF	/	/	/	/	/	/	/	/	/	/	/
65	NCE15MC037	MOHAMED JUNAID M C	/	/	/	/	/	/	/	/	/	/	/
66	NCE15MC043	NIRMAL C RAVINDRAN	/	/	/	/	/	/	/	/	/	/	/

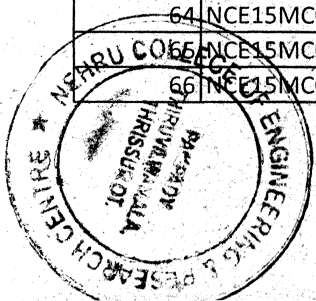



 PRINCIPAL  
 Nehru College of  
 Engineering and Research Centre  
 Pampady Thiruvilwamala, Thiruvananthapuram Dt  
 Pin - 680 597, Kerala

67	NCE15MC044	RAHULA M	✓	✓	✓	a	✓	✓	✓	✓	✓	a
----	------------	----------	---	---	---	---	---	---	---	---	---	---

PROGRAM COORDINATOR

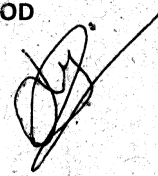
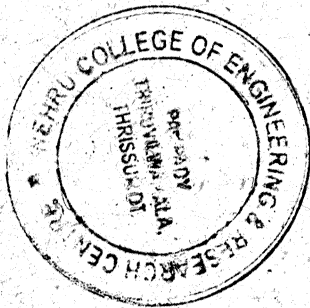

HOD

PRINCIPAL  
 Nehru College of  
 Engineering and Research Centre  
 Pampady Thiruvilwamala, Thiruvananthapuram Dt  
 Pin - 686 507 Kerala



**NEHRU COLLEGE OF ENGINEERING AND RESEARCH CENTRE**  
(NAAC Accredited)

(Approved by AICTE, Affiliated to APJ Abdul Kalam Technological University, Kerala)  
**ADD ON COURSE ANSWER KEY**



**SIGNALS AND SYSTEMS**

1. B
2. D
3. B
4. C
5. C
6. A
7. B
8. D
9. C
10. A
11. D
12. C
13. C
14. A
15. B
16. C
17. A
18. D
19. A
20. B
21. C
22. D
23. D
24. C
25. C
26. B
27. D
28. B
29. D
30. D
31. C
32. B
33. A
34. C
35. B

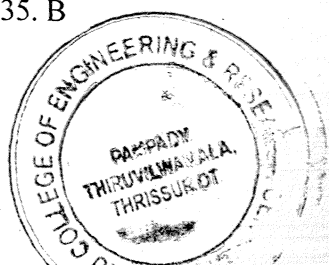

  
**PRINCIPAL**  
Nehru College of  
Engineering and Research Centre  
Pampady Thiruvilwamaala, Thrissur  
Pin - 680 597 Kerala

- 36. C
- 37. A
- 38. D
- 39. A
- 40. A
- 41. A
- 42. D
- 43. A
- 44. B
- 45. B
- 46. A
- 47. C
- 48. A
- 49. A
- 50. A

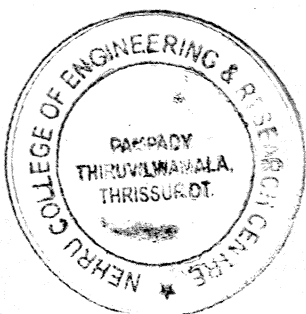

  
PRINCIPAL  
Nehru College of  
Engineering and Research Centre  
Pampady, Thiruvilwamala, Thrissur Dt  
Pin : 680 597 Kerala

Arjun S  
NCEISMCOIA.

14  
100



**NEHRU COLLEGE OF ENGINEERING AND RESEARCH CENTRE**  
(NAAC Accredited)

(Approved by AICTE, Affiliated to APJ Abdul Kalam Technological University, Kerala)

**CERTIFICATION COURSE QUESTION PAPER**



**SIGNALS AND SYSTEMS**

1. The type of systems which are characterized by input and the output quantized at certain levels are called as

- a) analog
- b) discrete ✓
- c) continuous
- d) digital

2. The type of systems which are characterized by input and the output capable of taking any value in a particular set of values are called as

- a) analog ✓
- b) discrete
- c) digital
- d) continuous

3. An example of a discrete set of information/system is

- a) the trajectory of the Sun
- b) data on a CD
- c) universe time scale
- d) movement of water through a pipe ✓

4. A system which is linear is said to obey the rules of

- a) scaling
- b) additivity
- c) both scaling and additivity ✓
- d) homogeneity

5. A time invariant system is a system whose output

- a) increases with a delay in input ✓
- b) decreases with a delay in input
- c) remains same with a delay in input
- d) vanishes with a delay in input

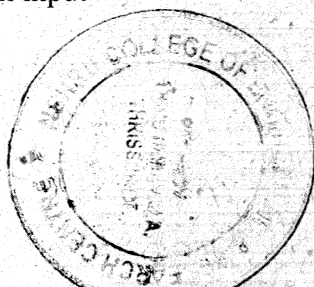

PRINCIPAL

Nehru College of  
Engineering and Research Centre  
Pampady Thiruvilwamala, Thrissur Dt  
Pin - 680 597 Kerala

6. Should real time instruments like oscilloscopes be time invariant?

- a) Yes ✓
- b) Sometimes
- c) Never
- d) They have no relation with time variance

View Answer

7. All real time systems concerned with the concept of causality are

- a) non causal
- b) causal ✓
- c) neither causal nor non causal
- d) memoryless

View Answer

8. A system is said to be defined as non causal, when

- a) the output at the present depends on the input at an earlier time ✓
- b) the output at the present does not depend on the factor of time at all
- c) the output at the present depends on the input at the current time
- d) the output at the present depends on the input at a time instant in the future

View Answer

9. When we take up design of systems, ideally how do we define the stability of a system?

- a) A system is stable, if a bounded input gives a bounded output, for some values of the input ✓
- b) A system is unstable, if a bounded input gives a bounded output, for all values of the input
- c) A system is stable, if a bounded input gives a bounded output, for all values of the input
- d) A system is unstable, if a bounded input gives a bounded output, for some values of the input

View Answer

10. All causal systems must have the component of

- a) memory
- b) time invariance
- c) stability
- d) linearity ✓

11. Amplifiers, motors, filters etc. are examples for which type of system?

- a) Distributed parameter systems ✓
- b) Unstable systems
- c) Discrete time systems
- d) Continuous time systems

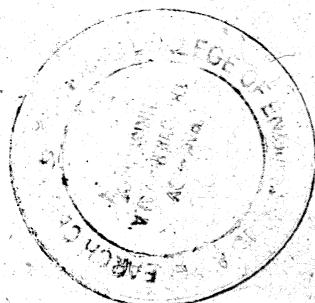

PRINCIPAL  
Mehru College of  
Engineering and Research Center  
Campus: The Gulabpura, Jaipur  
Pin: 302001, India

12. Which among the following systems are described by partial differential functions? ~~X~~

- a) Causal Systems and Dynamic systems
- b) Distributed parameter systems and linear systems
- c) Distributed parameter systems and Dynamic systems
- d) Causal systems and linear systems ✓

13. Which one of the following systems is causal? ~~X~~

- a)  $y(t) = x(t) + x(t-3) + x(t^2)$  ✓
- b)  $y(n) = x(n+2)$
- c)  $y(t) = x(t-1) + x(t-2)$
- d)  $y(n) = x(2n^2)$

14. Which among the following is not a linear system? ~~X~~

- a)  $y(n) = Cx(2n) + 2D$
- b)  $y(t) = \int_0^t x(w)dw$
- c)  $y(t) + 2y(t) = tx(t)$
- d)  $y(n) = x(n)\cos wn$  ✓

15. Determine the nature of the system,  $\frac{d^2y(t)}{dt^2} + 2\frac{dy(t)}{dt} + 4y^3(t) = x(t-4)$ . ~~X~~

- a) Static, linear, causal and time variant
- b) Dynamic, non-linear, causal and time invariant
- c) Static, non-linear, causal and time variant
- d) Dynamic, non-linear, causal and time variant ✓

16. Which one of the following is an example of a bounded signal? ~~X~~

- a)  $e^t \cos wt$  ✓
- b)  $e^t \sin w(-t)$
- c)  $e^{-t} \cos wt$
- d)  $e^t \cos w(-t)$

17. A system produces zero output for one input and same gives the same output for several other inputs. What is the system called? ~~X~~

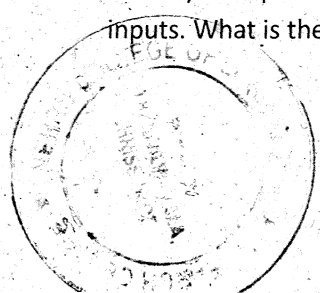

*[Signature]*  
PRINCIPAL  
Nehru College of  
Engineering and Research Centre  
Pampady, Thiruvilwamala, Thrissur Dt  
680 597 Kerala

- a) Non – invertible System
- b) Invertible system
- c) Non – causal system
- d) Causal system ✓

18. Which among the following is a LTI system? †

- a)  $dy(t)/dt + ty(t) = x(t)$  ✓
- b)  $y(t) = x(t)\cos\pi t$
- c)  $y(n) = x(n) + nx(n-1)$
- d)  $y(n) = x^3(n+1)$

19. Which of the following signals are monotonic in nature? †

- a)  $1 - \exp(-t)$
- b)  $1 - \exp(\sin(t))$
- c)  $\log(\tan(t))$
- d)  $\cos(t)$  ✓

20. What is the period of the following signal,  $x(t) = \sin(18\pi t + 78 \text{ deg})$ ?

- a)  $1/9$
- b)  $2/9$  ✓
- c)  $1/3$
- d)  $4/9$

21. Which of the following signals is monotonic? †

- a)  $x(t) = t^3 - 2t$  ✓
- b)  $x(t) = \sin(t)$
- c)  $x(t) = \sin^2 2(t) + \cos^2 2(t) - 2t$
- d)  $x(t) = \log(\cos(t))$

22. For the signal,  $x(t) = \log(\cos(a\pi t + d))$  for  $a = 50 \text{ Hz}$ , what is the time period of the signal, if periodic? †

- a)  $0.16\text{s}$  ✓
- b)  $0.08\text{s}$
- c)  $0.12\text{s}$
- d)  $0.04\text{s}$

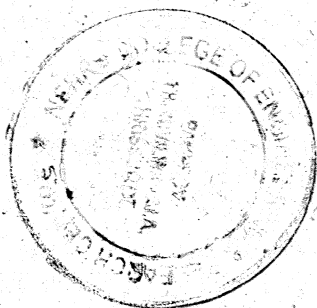

PRINCIPAL  
 Nehru College of  
 Engineering and Research Centre  
 Panipady Thiruvilwamala, Thrissur Dt  
 Pin 680 597 Kerala

23. What are the steady state values of the signals,  $1 - \exp(-t)$ , and  $1 - k \cdot \exp(-k \cdot t)$ ? X

- a) 1, k ✓
- b) 1,  $1/k$
- c) k, k
- d) 1, 1

24. For a bounded function, is the integral of the function from  $-\infty$  to  $+\infty$  defined and finite? X

- a) Yes ✓
- b) Never
- c) Not always
- d) None of the mentioned

25. For the signal  $x(t) = a - b \cdot \exp(-ct)$ , what is the steady state value, and the initial value? X

- a) c, b ✓
- b) c, c-a
- c) a, a-b
- d) b, a-b

26. For a double sided function, which is odd, what will be the integral of the function from  $-\infty$  to  $+\infty$  equal to? X

- a) Non-zero Finite ✓
- b) Zero
- c) Infinite
- d) None of the mentioned

27. Find where the signal  $x(t) = 1/(t^2 - 3t + 2)$  finds its maximum value between (1.25, 1.75): X

- a) 1.40 ✓
- b) 1.45
- c) 1.55
- d) 1.50

28. Is the signal  $x(t) = \exp(-t) \cdot \sin(t)$  periodic in nature? X

- a) Yes ✓
- b) No

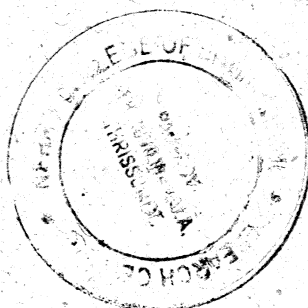

  
**PRINCIPAL**  
Nehru College of  
Engineering and Research Centre  
Pariyady, Thiruvilwamala, Thiruvananthapuram Dt  
Pin 680 597 Kerala

29. A signal is a physical quantity which does not vary with \_\_\_\_\_

- a) Time ✓
- b) Space
- c) Independent Variables
- d) Dependent Variables

30. Most of the signals found in nature are \_\_\_\_\_

- a) Continuous-time and discrete-time ✓
- b) Continuous-time and digital
- c) Digital and Analog
- d) Analog and Continuous-time

31. Which one of the following is not a characteristic of a deterministic signal?

- a) Exhibits no uncertainty ✓
- b) Instantaneous value can be accurately predicted
- c) Exhibits uncertainty
- d) Can be represented by a mathematical equation

32. Determine the fundamental period of the following signal:  $\sin 60t$ .

- a)  $1/60$  sec ✓
- b)  $1/30$  sec
- c)  $1/20$  sec
- d)  $1/10$  sec

33. Sum of two periodic signals is a periodic signal when the ratio of their time periods is \_\_\_\_\_

- a) A rational number
- b) An irrational number
- c) A complex number
- d) An integer ✓

34. Determine the Time period of:  $x(t) = 3 \cos (20t+5) + \sin (8t-3)$ .

- a)  $1/10$  sec ✓
- b)  $1/20$  sec
- c)  $2/5$  sec
- d)  $2/4$  sec

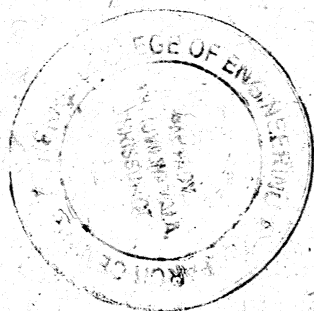

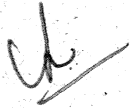
  
PRINCIPAL  
Nehru College of  
Engineering and Research Centre  
Panipady Thiruvilwamala, Thiruvananthapuram Dt  
Pin - 680 597 Kerala

35. What is the even component of a discrete-time signal?

a)  $x_e(t) = \frac{1}{2}[x(t) + x(-t)]$  X

b)  $x_e(n) = \frac{1}{2}[x(n) + x(-n)]$

c)  $x_e(t) = \frac{1}{2}[x(t) - x(-t)]$

d)  $x_e(n) = \frac{1}{2}[x(n) - x(-n)]$ . ✓

36. Determine the odd component of the signal:  $x(t) = \cos t + \sin t$ . X

a)  $\sin t$  ✓

b)  $2\sin t$

c)  $\cos t$

d)  $2\cos t$

38. Is the signal  $\sin(t)$  anti-symmetric? X

a) YES

b) NO ✓

39. For an energy signal \_\_\_\_\_ ✓

a)  $E=0$  ✓

b)  $P=\infty$

c)  $E=\infty$

d)  $P=0$

40. Determine the power of the signal:  $x(t) = \cos(t)$ . X

a)  $1/2$

b) 1

c)  $3/2$

d) 2 ✓

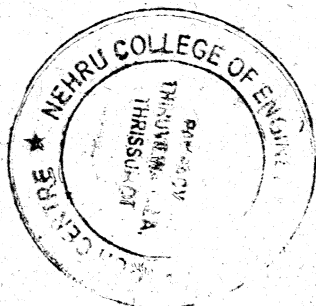

PRINCIPAL  
Nehru College of  
Engineering and Research Centre  
Panpady, Thruvankamala, Thrissur  
Pin - 686 007, Kerala

41. Is the following signal an energy signal? +

$$x(t) = u(t) - u(t - 1)$$

a) YES

b) NO ✓

42. A signal is anti-causal if \_\_\_\_\_ ✓

a)  $x(t) = 0$  for  $t = 0$

b)  $x(t) = 1$  for  $t < 0$

c)  $x(t) = 1$  for  $t > 0$

d)  $x(t) = 0$  for  $t > 0$  ✓

43. Is the signal  $x(t) = e^{at} u(t)$  causal? +

a) YES

b) NO ✓

44. Is the signal  $x(n) = u(n + 4) - u(n - 4)$  causal? +

a) YES ✓

b) NO

45. What is single-valued function? +

a) Single value for all instants of time

b) Unique value for every instant of time

c) A single pattern is followed by after 't' intervals

d) Different pattern of values is followed by after 't' intervals of time ✓

46. In real valued function and complex valued function, time is \_\_\_\_\_ +

a) Real

b) Complex

c) Imaginary

d) Not predictable ✓

47. Discrete time signal is derived from continuous time signal by \_\_\_\_\_ process. +

a) Addition

b) Multiplying

c) Sampling

d) Addition and multiplication ✓

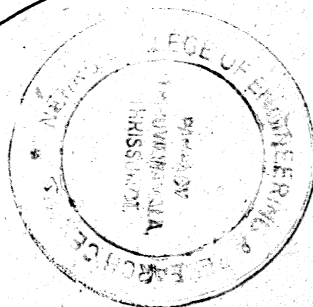

PRINCIPAL ✓

Nehru College of  
Engineering and Research Centre  
Pampady, Thiruvilvamala, Thiruvananthapuram  
Pin 680 597 Kerala

48. Even signals are symmetric about the vertical axis. ~~X~~

a) True

b) False ✓

49. If  $x(-t) = -x(t)$  then the signal is said to be \_\_\_\_\_ ~~X~~

a) Even signal

b) Odd signal

c) Periodic signal

d) Non periodic signal ✓

50. Which of the following is true for complex-valued function? ~~X~~

a)  $X(-t) = x^*(t)$

b)  $X(-t) = x(t)$

c)  $X(-t) = -x(t)$

d)  $X(-t) = x^*(-t)$  ✓

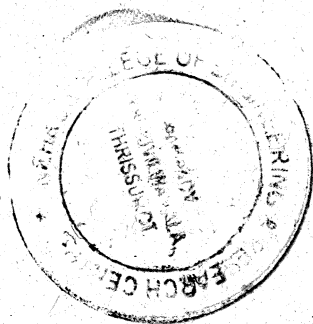

~~X~~  
PRINCIPAL  
Nehru College of  
Engineering and Research Centre  
Panipady Thiruvilwamala, Thiruvananthapuram  
Pin - 680 597 Kerala

Jerin Jose  
NCA NEMT 029

54  
100



**NEHRU COLLEGE OF ENGINEERING AND RESEARCH CENTRE**  
(NAAC Accredited)

(Approved by AICTE, Affiliated to APJ Abdul Kalam Technological University, Kerala)

**CERTIFICATION COURSE QUESTION PAPER**



**SIGNALS AND SYSTEMS**

1. The type of systems which are characterized by input and the output quantized at certain levels are called as ✕

- a) analog
- b) discrete ✓
- c) continuous
- d) digital

2. The type of systems which are characterized by input and the output capable of taking any value in a particular set of values are called as ✓

- a) analog
- b) discrete
- c) digital
- d) continuous ✓

3. An example of a discrete set of information/system is ✓

- a) the trajectory of the Sun
- b) data on a CD ✓
- c) universe time scale
- d) movement of water through a pipe

4. A system which is linear is said to obey the rules of ✓

- a) scaling
- b) additivity
- c) both scaling and additivity ✓
- d) homogeneity

5. A time invariant system is a system whose output ✕

- a) increases with a delay in input ✓
- b) decreases with a delay in input
- c) remains same with a delay in input
- d) vanishes with a delay in input

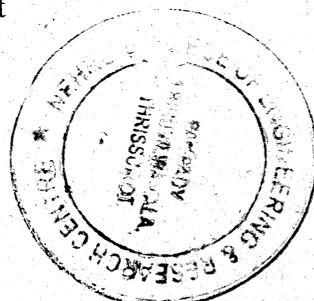

  
**PRINCIPAL**  
Nehru College of  
Engineering and Research Centre  
Pampady, Thiruvilwamala, Thirissur Dt.

6. Should real time instruments like oscilloscopes be time invariant?

- a) Yes ✓
- b) Sometimes ✓
- c) Never
- d) They have no relation with time variance

View Answer

7. All real time systems concerned with the concept of causality are

- a) non causal
- b) causal ✓
- c) neither causal nor non causal ✓
- d) memoryless

View Answer

8. A system is said to be defined as non causal, when

- a) the output at the present depends on the input at an earlier time
- b) the output at the present does not depend on the factor of time at all
- c) the output at the present depends on the input at the current time
- d) the output at the present depends on the input at a time instant in the future ✓

View Answer

9. When we take up design of systems, ideally how do we define the stability of a system?

- a) A system is stable, if a bounded input gives a bounded output, for some values of the input ✓
- b) A system is unstable, if a bounded input gives a bounded output, for all values of the input
- c) A system is stable, if a bounded input gives a bounded output, for all values of the input ✓
- d) A system is unstable, if a bounded input gives a bounded output, for some values of the input ~~XXXXXX~~

View Answer

10. All causal systems must have the component of

- a) memory ✓
- b) time invariance ✓
- c) stability
- d) linearity

11. Amplifiers, motors, filters etc. are examples for which type of system?

- a) Distributed parameter systems ✓
- b) Unstable systems
- c) Discrete time systems
- d) Continuous time systems ✓

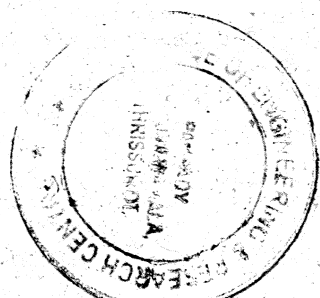

✓

PRINCIPAL

Neyyattur College of  
Engineering and Research Centre  
Pampady, Thiruvananthapuram, Thiruvananthapuram Dt  
Pin - 580 597, Kerala

12. Which among the following systems are described by partial differential functions? ~~X~~

- a) Causal Systems and Dynamic systems
- b) Distributed parameter systems and linear systems
- c) Distributed parameter systems and Dynamic systems ✓
- d) Causal systems and linear systems

13. Which one of the following systems is causal?

- a)  $y(t) = x(t) + x(t-3) + x(t^2)$  ✓
- b)  $y(n) = x(n+2)$
- c)  $y(t) = x(t-1) + x(t-2)$  ✓
- d)  $y(n) = x(2n^2)$

14. Which among the following is not a linear system?

- a)  $y(n) = Cx(2n) + 2D$ . ✓
- b)  $y(t) = \int_0^t x(w)dw$
- c)  $y(t) + 2y(t) = tx(t)$
- d)  $y(n) = x(n)\cos n$

Determine the nature of the system,  $\frac{d^2y(t)}{dt^2} + 2\frac{dy(t)}{dt} + 4y^3(t) = x(t-4)$ . ✓

15.

- a) Static, linear, causal and time variant
- b) Dynamic, non-linear, causal and time invariant ✓
- c) Static, non-linear, causal and time variant
- d) Dynamic, non-linear, causal and time variant

16. Which one of the following is an example of a bounded signal? ~~X~~

- a)  $e^t \cos wt$
- b)  $e^t \sin w(-t)$
- c)  $e^{-t} \cos wt$  ✓
- d)  $e^t \cos w(-t)$

17. A system produces zero output for one input and same gives the same output for several other inputs. What is the system called? ✓

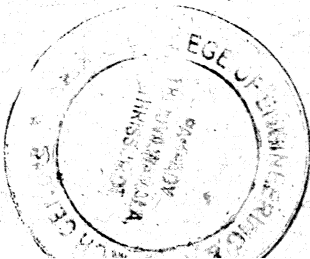

PRINCIPAL

Nehru College of  
Engineering and Research Centre  
Pampady, Thiruvananthapuram, Thiruvananthapuram Dt  
Dist - 696 507 Kerala

- a) Non – invertible System ✓
- b) Invertible system
- c) Non – causal system
- d) Causal system

18. Which among the following is a LTI system? ✓

- a)  $dy(t)/dt + ty(t) = x(t)$
- b)  $y(t) = x(t)\cos\pi t$
- c)  $y(n) = x(n) + nx(n-1)$
- d)  $y(n) = x^3(n+1)$  ✓

19. Which of the following signals are monotonic in nature? ✓

- a)  $1 - \exp(-t)$  ✓
- b)  $1 - \exp(\sin(t))$
- c)  $\log(\tan(t))$
- d)  $\cos(t)$

20. What is the period of the following signal,  $x(t) = \sin(18\pi t + 78 \text{ deg})$ ? +

- a)  $\frac{1}{9}$
- b)  $\frac{2}{9}$
- c)  $\frac{1}{3}$
- d)  $\frac{4}{9}$  ✓

21. Which of the following signals is monotonic? +

- a)  $x(t) = t^3 - 2t$  ✓
- b)  $x(t) = \sin(t)$
- c)  $x(t) = \sin^2(t) + \cos^2(t) - 2t$
- d)  $x(t) = \log(\cos(t))$

22. For the signal,  $x(t) = \log(\cos(a\pi t + d))$  for  $a = 50 \text{ Hz}$ , what is the time period of the signal, if periodic? +

- a) 0.16s ✓
- b) 0.08s
- c) 0.12s
- d) 0.04s



PRINCIPAL  
 Nehru College of  
 Engineering and Research Centre  
 Pampady Thiruvilvamala, Thrissur Dist  
 Pin - 680 597 Kerala

23. What are the steady state values of the signals,  $1 - \exp(-t)$ , and  $1 - k \cdot \exp(-k \cdot t)$ ?

- a) 1, k
- b) 1,  $1/k$
- c) k, k
- d) 1, 1

24. For a bounded function, is the integral of the function from  $-\infty$  to  $+\infty$  defined and finite?

- a) Yes
- b) Never
- c) Not always
- d) None of the mentioned

25. For the signal  $x(t) = a - b \cdot \exp(-ct)$ , what is the steady state value, and the initial value?

- a) c, b
- b) c,  $c - a$
- c) a,  $a - b$
- d) b,  $a - b$

26. For a double sided function, which is odd, what will be the integral of the function from  $-\infty$  to  $+\infty$  equal to?

- a) Non-zero Finite
- b) Zero
- c) Infinite
- d) None of the mentioned

27. Find where the signal  $x(t) = 1/(t^2 - 3t + 2)$  finds its maximum value between (1.25, 1.75):

- a) 1.40
- b) 1.45
- c) 1.55
- d) 1.50

28. Is the signal  $x(t) = \exp(-t) \cdot \sin(t)$  periodic in nature?

- a) Yes
- b) No

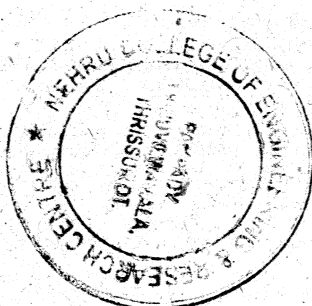

PRINCIPAL  
Nehru College of  
Engineering and Research Centre  
Pampady Thiruvikramapala  
Pin - 686 011

29. A signal is a physical quantity which does not vary with \_\_\_\_\_ ✓

- a) Time
- b) Space
- c) Independent Variables
- d) Dependent Variables ✓

30. Most of the signals found in nature are \_\_\_\_\_ ✓

- a) Continuous-time and discrete-time
- b) Continuous-time and digital
- c) Digital and Analog
- d) Analog and Continuous-time ✓

31. Which one of the following is not a characteristic of a deterministic signal? ✓

- a) Exhibits no uncertainty
- b) Instantaneous value can be accurately predicted
- c) Exhibits uncertainty ✓
- d) Can be represented by a mathematical equation

32. Determine the fundamental period of the following signal:  $\sin 60t$ . ✓

- a) 1/60 sec
- b) 1/30 sec ✓
- c) 1/20 sec
- d) 1/10 sec

33. Sum of two periodic signals is a periodic signal when the ratio of their time periods is \_\_\_\_\_ ✓

- a) A rational number
- b) An irrational number
- c) A complex number
- d) An integer ✓

34. Determine the Time period of:  $x(t) = 3 \cos(20t+5) + \sin(8t-3)$ . ✓

- a) 1/10 sec
- b) 1/20 sec
- c) 2/5 sec ✓
- d) 2/4 sec

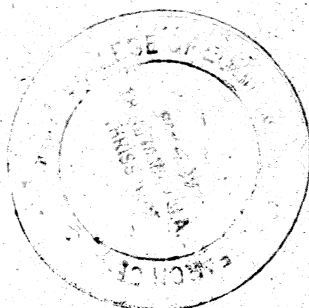

PRINCIPAL  
Nehru College of  
Engineering and Research Centre  
Thripady, Thrissur, Kerala

41. Is the following signal an energy signal? +

$$x(t) = u(t) - u(t - 1)$$

- a) YES
- b) NO ✓

42. A signal is anti-causal if \_\_\_\_\_ +

- a)  $x(t) = 0$  for  $t = 0$  ✓
- b)  $x(t) = 1$  for  $t < 0$
- c)  $x(t) = 1$  for  $t > 0$
- d)  $x(t) = 0$  for  $t > 0$

43. Is the signal  $x(t) = e^{at} u(t)$  causal? +

- a) YES
- b) NO ✓

44. Is the signal  $x(n) = u(n + 4) - u(n - 4)$  causal? +

- a) YES ✓
- b) NO

45. What is single-valued function? X

- a) Single value for all instants of time ✓
- b) Unique value for every instant of time
- c) A single pattern is followed by after 't' intervals
- d) Different pattern of values is followed by after 't' intervals of time

46. In real valued function and complex valued function, time is \_\_\_\_\_ +

- a) Real
- b) Complex
- c) Imaginary
- d) Not predictable ✓

47. Discrete time signal is derived from continuous time signal by \_\_\_\_\_ process. +

- a) Addition ✓
- b) Multiplying
- c) Sampling
- d) Addition and multiplication

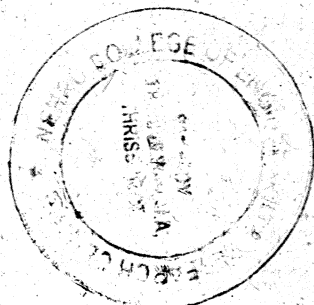

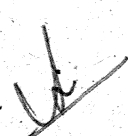
  
PRINCIPAL  
Nehru College of  
Engineering and Research Centre  
Pampady, Thiruvilwamala, Thiruvananthapuram Dt  
Pin - 680 597 Kerala

35. What is the even component of a discrete-time signal?

a)  $x_e(t) = \frac{1}{2} [x(t) + x(-t)]$  ✗

b)  $x_e(n) = \frac{1}{2} [x(n) + x(-n)]$

c)  $x_e(t) = \frac{1}{2} [x(t) - x(-t)]$

d)  $x_e(n) = \frac{1}{2} [x(n) - x(-n)]$  ✓

36. Determine the odd component of the signal:  $x(t) = \cos t + \sin t$ .

a)  $\sin t$

b)  $2\sin t$

c)  $\cos t$  ✓

d)  $2\cos t$

38. Is the signal  $\sin(t)$  anti-symmetric? ✗

a) YES

b) NO ✓

39. For an energy signal \_\_\_\_\_ ✗

a)  $E=0$

b)  $P=\infty$

c)  $E=\infty$

d)  $P=0$  ✓

40. Determine the power of the signal:  $x(t) = \cos(t)$ . ✗

a)  $1/2$

b) 1

c)  $3/2$

d) 2 ✓

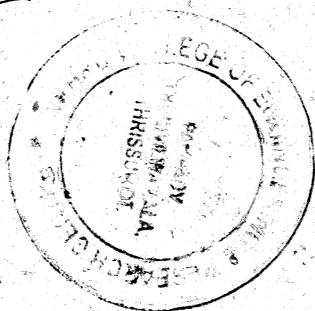

PRINCIPAL

Nehru College of

Engineering and Research Centre

Pampady Thiruvananthapuram, Kerala

Pin - 696 301, Kerala

48. Even signals are symmetric about the vertical axis. ~~X~~

- a) True
- b) False ✓

49. If  $x(-t) = -x(t)$  then the signal is said to be \_\_\_\_\_ ~~X~~

- a) Even signal
- b) Odd signal
- c) Periodic signal
- d) Non periodic signal ✓

50. Which of the following is true for complex-valued function? ~~X~~

- a)  $X(-t) = x^*(t)$
- b)  $X(-t) = x(t)$
- c)  $X(-t) = -x(t)$
- d)  $X(-t) = x^*(-t)$  ✓

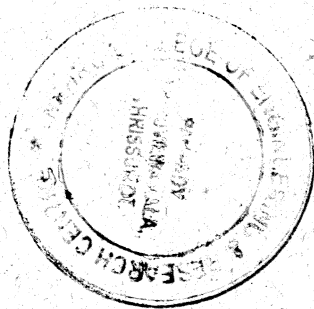

  
PRINCIPAL  
Nehru College of  
Engineering and Research Centre  
Panipady Thiruvilwamala, Thrissur District  
Pin 680 597 Kerala

Shyama Prasad O.K

NCANGMTOAB



**NEHRU COLLEGE OF ENGINEERING AND RESEARCH CENTRE**  
(NAAC Accredited)

(Approved by AICTE, Affiliated to APJ Abdul Kalam Technological University, Kerala)  
**CERTIFICATION COURSE QUESTION PAPER**



**SIGNALS AND SYSTEMS**

1. The type of systems which are characterized by input and the output quantized at certain levels are called as

- a) analog
- b) discrete ✓
- c) continuous
- d) digital

2. The type of systems which are characterized by input and the output capable of taking any value in a particular set of values are called as

- a) analog ✓
- b) discrete
- c) digital
- d) continuous

3. An example of a discrete set of information/system is

- a) the trajectory of the Sun
- b) data on a CD ✓
- c) universe time scale
- d) movement of water through a pipe

4. A system which is linear is said to obey the rules of

- a) scaling
- b) additivity
- c) both scaling and additivity ✓
- d) homogeneity

5. A time invariant system is a system whose output

- a) increases with a delay in input
- b) decreases with a delay in input
- c) remains same with a delay in input ✓
- d) vanishes with a delay in input

7.6  
-----  
10.0

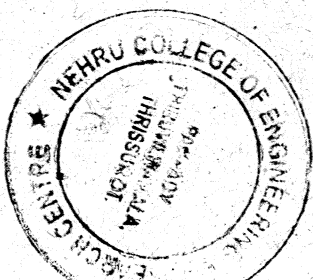

*Handwritten signature*

**PRINCIPAL**  
Nehru College of  
Engineering and Research Centre  
Pampady Thiruvilvamala Thiruvananthapuram  
Pin - 680 547 Kerala

6. Should real time instruments like oscilloscopes be time invariant?

- a) Yes ✓
- b) Sometimes
- c) Never
- d) They have no relation with time variance

View Answer

7. All real time systems concerned with the concept of causality are ✓

- a) non causal
- b) causal ✓
- c) neither causal nor non causal
- d) memoryless

View Answer

8. A system is said to be defined as non causal, when ✓

- a) the output at the present depends on the input at an earlier time
- b) the output at the present does not depend on the factor of time at all
- c) the output at the present depends on the input at the current time
- d) the output at the present depends on the input at a time instant in the future ✓

View Answer

9. When we take up design of systems, ideally how do we define the stability of a system? ✓

- a) A system is stable, if a bounded input gives a bounded output, for some values of the input ✓
- b) A system is unstable, if a bounded input gives a bounded output, for all values of the input
- c) A system is stable, if a bounded input gives a bounded output, for all values of the input
- d) A system is unstable, if a bounded input gives a bounded output, for some values of the input

View Answer

10. All causal systems must have the component of ✓

- a) memory ✓
- b) time invariance
- c) stability
- d) linearity

11. Amplifiers, motors, filters etc. are examples for which type of system? ✓

- a) Distributed parameter systems
- b) Unstable systems
- c) Discrete time systems
- d) Continuous time systems ✓

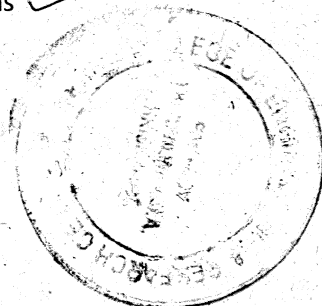

PRINCIPAL  
Nehru College of  
Engineering and Research Centre  
Pampady, Thiruvilwamala, Thrissur Dt.  
Pin: 680 597, Kerala

12. Which among the following systems are described by partial differential functions?

- a) Causal Systems and Dynamic systems ✓
- b) Distributed parameter systems and linear systems
- c) Distributed parameter systems and Dynamic systems ✓
- d) Causal systems and linear systems

13. Which one of the following systems is causal?

- a)  $y(t) = x(t) + x(t-3) + x(t^2)$  ✓
- b)  $y(n) = x(n+2)$
- c)  $y(t) = x(t-1) + x(t-2)$  ✓
- d)  $y(n) = x(2n^2)$

14. Which among the following is not a linear system? X

- a)  $y(n) = Cx(2n) + 2D$
- b)  $y(t) = \int_0^t x(w)dw$
- c)  $y'(t) + 2y(t) = tx(t)$
- d)  $y(n) = x(n)\cos n$  ✓

Determine the nature of the system,  $\frac{d^2y(t)}{dt^2} + 2\frac{dy(t)}{dt} + 4y^3(t) = x(t-4)$ .

15. ✓

- a) Static, linear, causal and time variant
- b) Dynamic, non-linear, causal and time invariant ✓
- c) Static, non-linear, causal and time variant
- d) Dynamic, non-linear, causal and time variant

16. Which one of the following is an example of a bounded signal?

- a)  $e^t \cos wt$
- b)  $e^t \sin w(-t)$
- c)  $e^{-t} \cos wt$  ✓
- d)  $e^t \cos w(-t)$

17. A system produces zero output for one input and same gives the same output for several other inputs. What is the system called? X

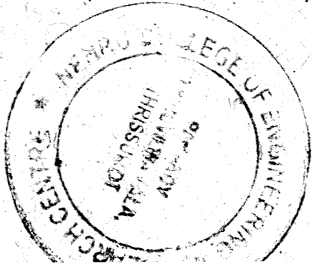

↓  
PRINCIPAL  
Mehru College of  
Engineering and Research Centre  
Pampady Thiruvilwamala, Thiruvananthapuram  
Pin - 689 566, Kerala

- a) Non – invertible System
- b) Invertible system
- c) Non – causal system
- d) Causal system ✓

18. Which among the following is a LTI system? X

- a)  $dy(t)/dt + ty(t) = x(t)$  ✓
- b)  $y(t) = x(t) \cos \pi t$
- c)  $y(n) = x(n) + nx(n-1)$
- d)  $y(n) = x^3(n+1)$

19. Which of the following signals are monotonic in nature? ✓

- a)  $1 - \exp(-t)$  ✓
- b)  $1 - \exp(\sin(t))$
- c)  $\log(\tan(t))$
- d)  $\cos(t)$

20. What is the period of the following signal,  $x(t) = \sin(18\pi t + 78 \text{ deg})$ ? X

- a)  $1/9$
- b)  $2/9$
- c)  $1/3$
- d)  $4/9$  ✓

21. Which of the following signals is monotonic? ✓

- a)  $x(t) = t^3 - 2t$
- b)  $x(t) = \sin(t)$
- c)  $x(t) = \sin^2(t) + \cos^2(t) - 2t$  ✓
- d)  $x(t) = \log(\cos(t))$

22. For the signal,  $x(t) = \log(\cos(a\pi t + d))$  for  $a = 50 \text{ Hz}$ , what is the time period of the signal, if periodic? X

- a) 0.16s ✓
- b) 0.08s
- c) 0.12s
- d) 0.04s

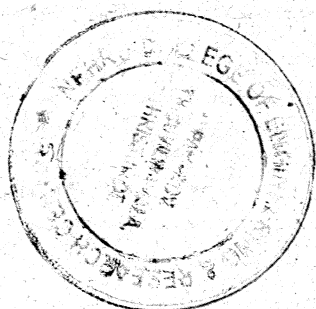

PRINCIPAL  
Nehru College of  
Engineering and Research Centre  
Panipady Thiruvilwamala, Thiruvananthapuram, Dt.  
Pin: 680 597, Kerala

23. What are the steady state values of the signals,  $1 - \exp(-t)$ , and  $1 - k \cdot \exp(-k \cdot t)$ ? ✓

- a) 1, k
- b) 1,  $1/k$
- c) k, k
- d) 1, 1 ✓

24. For a bounded function, is the integral of the function from  $-\infty$  to  $+\infty$  defined and finite? X

- a) Yes ✓
- b) Never
- c) Not always
- d) None of the mentioned

25. For the signal  $x(t) = a - b \cdot \exp(-ct)$ , what is the steady state value, and the initial value? ✓

- a) c, b
- b) c,  $c - a$
- c) a,  $a - b$  ✓
- d) b,  $a - b$

26. For a double sided function, which is odd, what will be the integral of the function from  $-\infty$  to  $+\infty$  equal to? X

- a) Non-zero Finite ✓
- b) Zero
- c) Infinite
- d) None of the mentioned

27. Find where the signal  $x(t) = 1/(t^2 - 3t + 2)$  finds its maximum value between (1.25, 1.75): ✓

- a) 1.40
- b) 1.45
- c) 1.55
- d) 1.50 ✓

28. Is the signal  $x(t) = \exp(-t) \cdot \sin(t)$  periodic in nature? X

- a) Yes ✓
- b) No

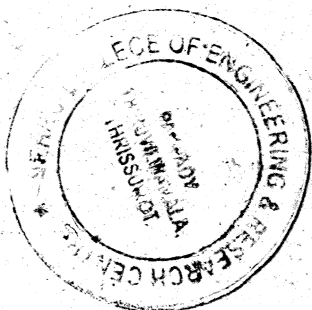

PRINCIPAL

Nahrain College of  
Engineering and Research Centre  
Tikrit

29. A signal is a physical quantity which does not vary with \_\_\_\_\_ ✓

- a) Time
- b) Space
- c) Independent Variables
- d) Dependent Variables ✓

30. Most of the signals found in nature are \_\_\_\_\_ ✓

- a) Continuous-time and discrete-time
- b) Continuous-time and digital
- c) Digital and Analog
- d) Analog and Continuous-time ✓

31. Which one of the following is not a characteristic of a deterministic signal? ✓

- a) Exhibits no uncertainty
- b) Instantaneous value can be accurately predicted
- c) Exhibits uncertainty ✓
- d) Can be represented by a mathematical equation

32. Determine the fundamental period of the following signal:  $\sin 60t$ . ✓

- a) 1/60 sec
- b) 1/30 sec ✓
- c) 1/20 sec
- d) 1/10 sec

33. Sum of two periodic signals is a periodic signal when the ratio of their time periods is \_\_\_\_\_ ✓

- a) A rational number ✓
- b) An irrational number
- c) A complex number
- d) An integer

34. Determine the Time period of:  $x(t) = 3 \cos(20t+5) + \sin(8t-3)$ . ✓

- a) 1/10 sec
- b) 1/20 sec
- c) 2/5 sec ✓
- d) 2/4 sec



✓

**PRINCIPAL**  
Nehru College of  
Engineering and Research Centre  
Pampady Thiruvananthapuram, Kerala  
Pin - 690 507, Kerala

35. What is the even component of a discrete-time signal? X

a)  $x_e(t) = \frac{1}{2}[x(t) + x(-t)]$

b)  $x_e(n) = \frac{1}{2}[x(n) + x(-n)]$

c)  $x_e(t) = \frac{1}{2}[x(t) - x(-t)]$

d)  $x_e(n) = \frac{1}{2}[x(n) - x(-n)]$  ✓

36. Determine the odd component of the signal:  $x(t) = \cos t + \sin t$ .

a)  $\sin t$

b)  $2\sin t$

c)  $\cos t$  ✓

d)  $2\cos t$

38. Is the signal  $\sin(t)$  anti-symmetric? ✓

a) YES ✓

b) NO

39. For an energy signal \_\_\_\_\_ ✓

a)  $E=0$  ✓

b)  $P=\infty$

c)  $E=\infty$

d)  $P=0$

40. Determine the power of the signal:  $x(t) = \cos(t)$ . ✓

a)  $1/2$  ✓

b) 1

c)  $3/2$

d) 2

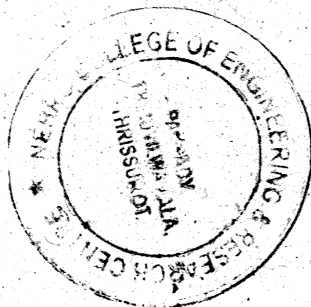

PRINCIPAL  
Nery College of  
Engineering and Research Centre  
Panipady, Thiruvananthapuram, Thiruvananthapuram Dt.  
Pin - 680 597 Kerala

41. Is the following signal an energy-signal? ✓

$$x(t) = u(t) - u(t-1)$$

- a) YES ✓
- b) NO

42. A signal is anti-causal if \_\_\_\_\_ ✓

- a)  $x(t) = 0$  for  $t = 0$
- b)  $x(t) = 1$  for  $t < 0$
- c)  $x(t) = 1$  for  $t > 0$
- d)  $x(t) = 0$  for  $t > 0$  ✓

43. Is the signal  $x(t) = e^{at} u(t)$  causal? ✓

- a) YES ✓
- b) NO

44. Is the signal  $x(n) = u(n+4) - u(n-4)$  causal? ✗

- a) YES ✓
- b) NO

45. What is single-valued function? ✓

- a) Single value for all instants of time
- b) Unique value for every instant of time ✓
- c) A single pattern is followed by after 't' intervals
- d) Different pattern of values is followed by after 't' intervals of time

46. In real valued function and complex valued function, time is \_\_\_\_\_ ✓

- a) Real ✓
- b) Complex
- c) Imaginary
- d) Not predictable

47. Discrete time signal is derived from continuous time signal by \_\_\_\_\_ process. ✓

- a) Addition
- b) Multiplying
- c) Sampling ✓
- d) Addition and multiplication

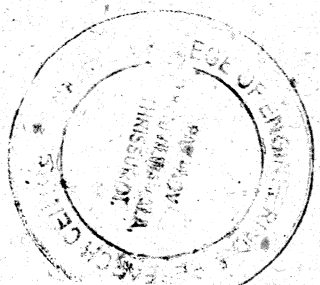

PRINCIPAL  
National Institute of  
Engineering and Research Centre  
Pampady, Thiruvananthapuram, Thiruvananthapuram Dt.  
Pin: 680 597, Kerala

48. Even signals are symmetric about the vertical axis.

- a) True
- b) False

49. If  $x(-t) = -x(t)$  then the signal is said to be

- a) Even signal
- b) Odd signal
- c) Periodic signal
- d) Non periodic signal

50. Which of the following is true for complex-valued function?

- a)  $X(-t) = X^*(t)$
- b)  $X(-t) = X(t)$
- c)  $X(-t) = -X(t)$
- d)  $X(-t) = X^*(-t)$

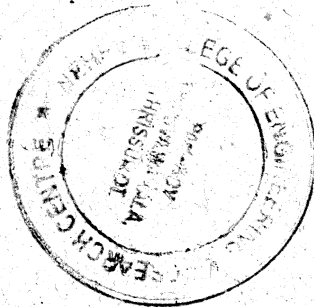

PRINCIPAL  
Narasimha Rao of  
Engineering Research Centre  
Pampady, Thiruvalluvar University, Tirunelveli, Dt  
Pin - 626 502, Kerala



**NEHRU COLLEGE OF ENGINEERING AND RESEARCH CENTRE**  
**(NAAC Accredited)**  
(Approved by AICTE, Affiliated to APJAKTU & Calicut University, Kerala)  
ACADAMIC YEAR (2015-16)



**DEPARTMENT OF MECHATRONICS ENGINEERING**  
**OFFERING CERTIFIED COURSE ON**  
**SIGNALS AND SYSTEMS**

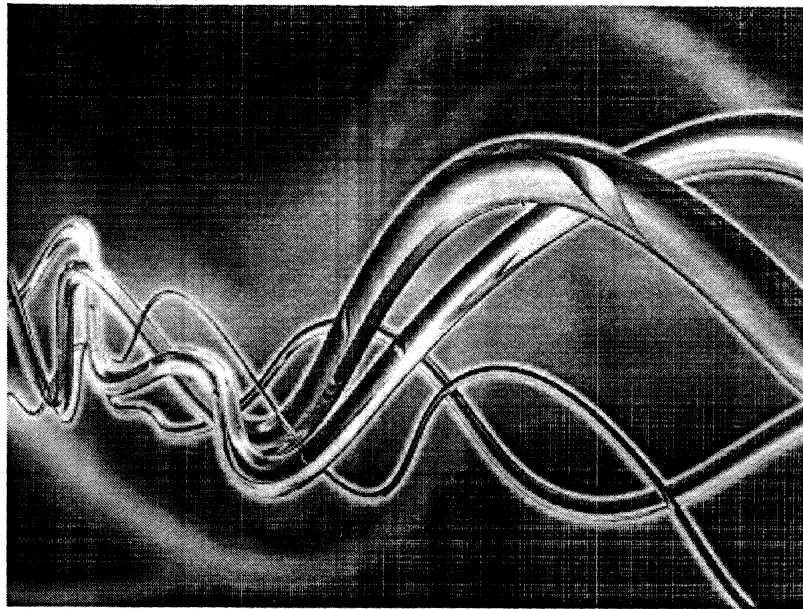

**COURSE POINTS**

- ✓ CLASSIFICATION OF SIGNALS
- ✓ TIME DOMAIN REPRESENTATION OF LTI SYSTEM
- ✓ FOURIER REPRESENTATION OF PERIODIC SIGNALS
- ✓ FOURIER REPRESENTATION OF APERIODIC SIGNALS

**FACULTY**





**PRINCIPAL**  
Nehru College of  
Engineering and Research Centre  
Pampady, Thiruvilwamala, Thrissur  
Pin 680 597 Kerala

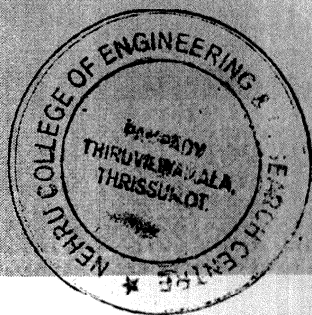

# Certificate OF COMPLETION

.....ATHUL ASITH K (NCANEMT09).....had successfully completed  
the Certified course "SIGNALS AND SYSTEM" during 2015-16 conducted by the  
Department of Mechatronics Engineering, Nehru College of Engineering and  
Research Centre, Pampady, Thrissur.



  
PROGRAM CO-ORDINATOR

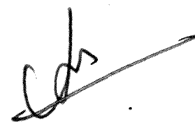

  
HEAD OF DEPARTMENT PRINCIPAL

Nehru College of  
Engineering and Research Centre  
Pampady, Thiruvananthapuram  
Pin - 689 037, Kerala



# Certificate OF COMPLETION

.....Soumya. A K (NCANEMT053).....had successfully completed  
the Certified course "SIGNALS AND SYSTEM" during 2015-16 conducted by the  
Department of Mechatronics Engineering, Nehru College of Engineering and  
Research Centre, Pampady, Thrissur.

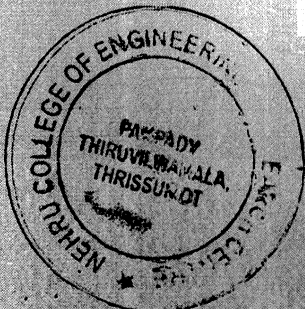

PROGRAM CO-ORDINATOR

HEAD OF DEPARTMENT

For INCOPIAT  
Nehru College of  
Engineering and Research Centre  
Pampady, Thiruvananthapuram, Thrissur  
Pin 680 590 Kerala



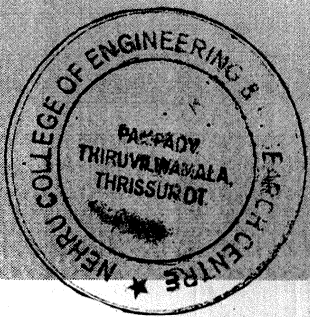

# Certificate OF COMPLETION

.....VARSHA CK (NCANEMT 054).....had successfully completed  
the Certified course "SIGNALS AND SYSTEM" during 2015-16 conducted by the  
Department of Mechatronics Engineering, Nehru College of Engineering and  
Research Centre, Pampady, Thrissur.

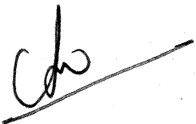

  
PROGRAM CO-ORDINATOR



  
HEAD OF DEPARTMENT

PRINCIPAL

Nehru College of  
Engineering and Research Centre  
Pampady, Thiruvilwamala, Thrissur  
Pin - 680 597 Kerala

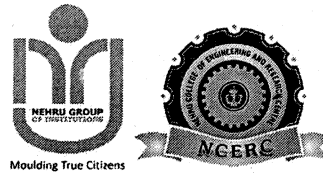

# Certificate OF COMPLETION

.....ABY POIUSON (NCAOEMTDO4).....had successfully completed  
the Certified course "SIGNALS AND SYSTEM" during 2015-16 conducted by the  
Department of Mechatronics Engineering, Nehru College of Engineering and  
Research Centre, Pampady, Thrissur.

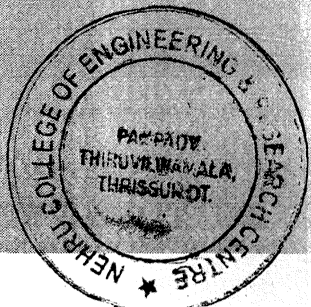

  
PROGRAM CO-ORDINATOR

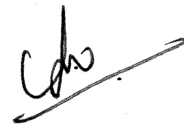

  
HEAD OF DEPARTMENT

PRINCIPAL  
Nehru College of  
Engineering and Research Centre  
Pampady, Thiruvananthala, Thrissur  
Pin - 680 597 Kerala



# Certificate OF COMPLETION

.....DEEPU VINIL (NCEISMCO22).....had successfully completed  
the Certified course "SIGNALS AND SYSTEM" during 2015-16 conducted by the  
Department of Mechatronics Engineering, Nehru College of Engineering and  
Research Centre, Pampady, Thrissur.

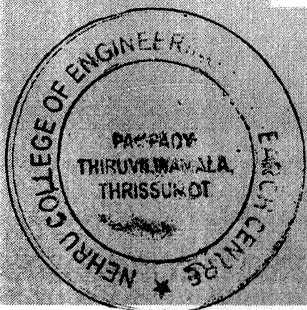

PROGRAM CO-ORDINATOR

HEAD OF DEPARTMENT

PRINCIPAL  
Nehru College of  
Engineering and Research Centre  
Pampady, Thrissur  
Pin - 680 501



**NEHRU COLLEGE OF ENGINEERING AND RESEARCH CENTRE  
(NAAC Accredited)**

(Approved by AICTE, Affiliated to University of Calicut & APJ Abdul Kalam Technological University, Kerala)



**ADMISSION TO CERTIFICATION COURSE (2015-2016)**

Applications are invited for admission for the Certification Course 'HEAT AND MASS TRANSFER' offered by the Department of Mechatronics Engineering, Nehru college of Engineering and Research Centre, Pampady, Thrissur.

**Eligibility criteria**

All UG engineering students of MTR Department are eligible

**Timing:**

1 hour per day from 4.00pm to 5.00pm for 30 hours of the course. Saturday and Sunday may be used at the discretion of the department.

**Attendance**

A minimum of 75% attendance is required for writing the examination.

**Important Dates**

Commencement of classes: 21-08-2015

Examination Date: 09-11-2015

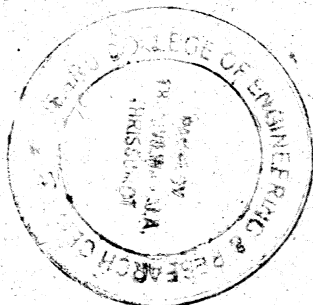

HOD

PRINCIPAL  
Nehru College of  
Engineering and Research Centre  
Pampady, Thiruvilwamala, Thrissur Dt  
Pin: 680 597 Kerala

FROM

MR. DHANESH S

ASSISTANT PROFESSOR

MTR DEPARTMENT, NCERC PAMPADY

TO

HEAD OF THE DEPARTMENT

MTR DEPARTMENT

NCERC PAMPADY

SUBJECT: Requisition for conducting Certification Course on "HEAT AND MASS TRANSFER".

Respected Sir,

As the Assistant Professor of Mechatronics Engineering, I would like to request your support and permission to conduct a Certification Course on "HEAT AND MASS TRANSFER" from 21-08-2015. It will be a 30 hour course scheduled for July to October of this year. It is therefore important for students to have a deep understanding of upcoming methodologies to enhance knowledge dissemination to students for doing projects.

All UG Engineering students of MTR Department are eligible for this course.

Sincerely,



PLACE: PAMPADY

DATE: 4/7/15

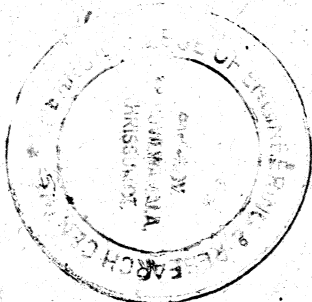

  
PRINCIPAL  
Nehru College of  
Engineering and Research Centre  
Pampady, Thiruvilwamala, Thrissur  
Pin 680 597 Kerala

FROM

MR. DHANESH S

ASSISTANT PROFESSOR

MTR DEPARTMENT, NCERC PAMPADY

TO

THE PRINCIPAL,

NCERC PAMPADY

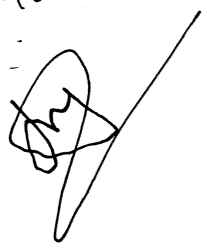
Forwarded to Principal  

Through HOD

SUBJECT: Requisition for conducting Certification Course on "HEAT AND MASS TRANSFER" Reg.

Respected Sir,

Students need a deep understanding of upcoming methodologies to enhance knowledge dissemination for doing projects. Artificial Neural network can be used for machine learning and data mining, so Mechatronics Engineering department would like to conduct a Certification Course on "HEAT AND MASS TRANSFER" from 21-08-2015. It will be a 30 hour course scheduled for July to October of this academic year 2015-2016. Kindly request you to give the permission for the same.

All UG Engineering students of MTR Department are eligible for this course.

Sincerely,

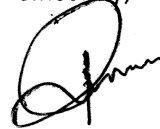

PLACE: PAMPADY

DATE: 3/8/15

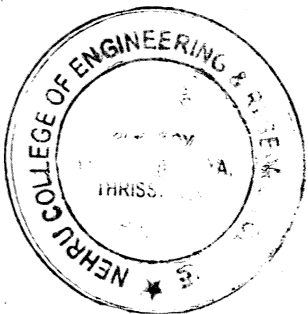
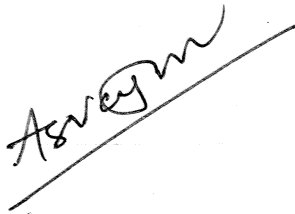

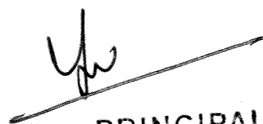
  
PRINCIPAL  
Nehru College of  
Engineering and Research Centre  
Pampady Thiruvilwamala, Thiruvananthapuram Dt  
689 507 Kerala

# NEHRU COLLEGE OF ENGINEERING AND RESEARCH CENTRE

(ACCREDITED BY NAAC)

PAMPADY, THIRUVILWAMALA, THRISSUR DIST.

## MINUTES OF DEPARTMENT ADVISORY COMMITTEE MEETING HELD ON 11/07/2015

A meeting of the Department Advisory Committee (DAC) was held on 11<sup>th</sup> July 2015 at 3:00 PM in the chamber of HoD, MTR department.

The following members were present:

1. Prof. Radhakrishnan - HoD, MTR Dept.
2. Mr. Niveth L-Assistant Professor, MTR Dept.
3. Mr. Midhunraj P K-Assistant Professor, MTR Dept.
4. Mr. Ranjith P N-Assistant Professor, MTR Dept.
5. Mr. Dhanesh S-Assistant Professor, MTR Dept.

The following decisions were taken:

1. It was decided to conduct a certificate course on "HEAT AND MASS TRANSFER" during the second and fourth Saturdays of the academic year 2015-16 for a period of 30 hours.
2. The course will enhance the knowledge level of students in the field of heat and mass transfer.
3. It was decided to provide the course for the UG students of Mechatronics Engg. Department.
4. Also, it was decided to ensure compulsory attendance and staff advisors should monitor the same.

The meeting came to an end at 3:50 PM.

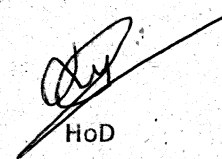
  
HoD

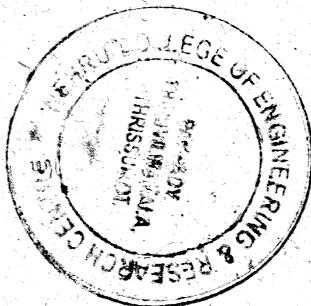

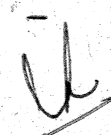

PRINCIPAL  
Nehru College of  
Engineering and Research Centre  
Pampady, Thiruvilwamala, Thrissur Dt  
Pin 680 597, Kerala



**NEHRU COLLEGE OF ENGINEERING AND RESEARCH CENTRE  
(NAAC Accredited)**

(Approved by AICTE, Affiliated to APJ Abdul Kalam Technological University, Kerala)  
**ADD ON COURSE SYLLABUS AND SCHEDULE**



## **HEAT AND MASS TRANSFER**

### **OBJECTIVES:**

- To understand the mechanisms of heat transfer under steady and transient conditions.
- To understand the concepts of heat transfer through extended surfaces.
- To learn the thermal analysis and sizing of heat exchangers and to understand the basic concepts of mass transfer.

(Use of standard HMT data book permitted)

### **UNIT I CONDUCTION**

General Differential equation of Heat Conduction– Cartesian and Polar Coordinates – One Dimensional Steady State Heat Conduction — plane and Composite Systems – Conduction with Internal Heat Generation – Extended Surfaces – Unsteady Heat Conduction – Lumped Analysis – Semi Infinite and Infinite Solids –Use of Heisler’s charts.

### **UNIT II CONVECTION**

Free and Forced Convection – Hydrodynamic and Thermal Boundary Layer. Free and Forced Convection during external flow over Plates and Cylinders and Internal flow through tubes .

### **UNIT III PHASE CHANGE HEAT TRANSFER AND HEAT EXCHANGERS**

Nusselt’s theory of condensation – Regimes of Pool boiling and Flow boiling. Correlations in boiling and condensation. Heat Exchanger Types – Overall Heat Transfer Coefficient – Fouling Factors – Analysis – LMTD method – NTU method.

### **UNIT IV RADIATION & MASS TRANSFER**

Black Body Radiation – Grey body radiation – Shape Factor – Electrical Analogy – Radiation Shields. Basic Concepts – Diffusion Mass Transfer – Fick’s Law of Diffusion – Steady state Molecular Diffusion – Convective Mass Transfer – Momentum, Heat and Mass Transfer Analogy –Convective Mass Transfer Correlations.

### **COURSE SCHEDULE**

Commencement of classes: 21-08-2015

Examination Date: 09-11-2015

  
**PROGRAM COORDINATOR**

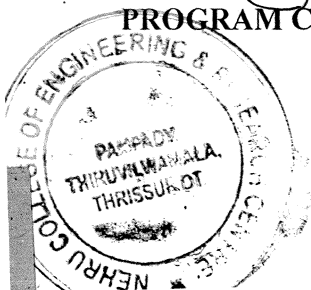

  
**HOD**

  
**PRINCIPAL**  
Nehru College of  
Engineering and Research Centre  
Pampady, Thiruvilwamala, Thrissur Dt  
Pin 680 597 Kerala

**NEHRU COLLEGE OF ENGINEERING & RESEARCH CENTRE**

Pampady, Thiruvilwamala, Thrissur Dt.

**DEPARTMENT OF MECHATRONICS ENGINEERING**

**HEAT AND MASS TRANSFER**

Attendance Sheet

SL. NO.	REG. NO.	NAME OF STUDENT	22/8/15	22/8/15	23/8/15	23/8/15	31/8/15	6/9/15	6/9/15	12/9/15	12/9/15	13/9/15
1	NCANEMT002	ADITHYA SURESH	A	/	/	/	A	/	/	/	/	/
2	NCANEMT003	AKARSH S	/	A	/	/	/	/	/	A	/	/
3	NCANEMT005	AKSHAY M	/	/	A	/	/	A	/	/	/	/
4	NCANEMT006	ALOSHIOUS M DASAN	/	/	/	A	/	/	A	/	/	/
5	NCANEMT008	ANARGH VISWANATH	/	A	/	/	A	/	/	/	/	/
6	NCANEMT010	ANEESH K A	A	/	/	/	/	/	/	/	/	/
7	NCANEMT014	ARJUN P MENON	A	/	/	/	/	/	/	/	/	/
8	NCANEMT015	ARJUN VYSAKH C	/	/	/	/	/	/	/	/	/	/
9	NCANEMT017	ASHWIN K J	/	A	/	/	/	/	/	/	/	/
10	NCANEMT018	ASHWIN VARGHESE	/	/	/	/	/	/	/	/	/	/
11	NCANEMT022	CIBIN JOHN JOSEPH	/	A	/	/	/	/	/	/	/	/
12	NCANEMT023	DINILKUMAR K	/	/	A	/	/	/	/	/	/	/
13	NCANEMT027	HARIKRISHNAN P	/	/	/	/	/	A	/	/	/	/
14	NCANEMT028	IRSHAD MOHAMED GHANI	A	/	/	/	/	/	/	/	/	/
15	NCANEMT031	JITHU J	A	/	/	A	/	/	/	/	/	/
16	NCANEMT032	JYOTHISH M N	/	/	/	/	/	/	A	/	/	/
17	NCANEMT035	MOHAMMED SHIHAS K	/	A	/	/	/	/	/	/	/	/
18	NCANEMT039	PRAVEEN PRAKASH	/	/	/	/	/	/	/	/	/	/
19	NCANEMT042	RIDUL RAZWIN M R	/	A	/	/	/	/	/	/	A	/
20	NCANEMT045	SHAHSAD M	/	/	/	/	/	A	/	/	/	A
21	NCANEMT050	VISHNUDAS M	A	/	/	/	/	/	/	/	/	/
22	NCANEMT051	VISHNU PRASAD	/	/	/	A	/	/	/	A	/	/
23	NCAOEMT011	ALEN BABY	A	/	/	/	/	/	/	/	/	/
24	NCAOEMT012	ALISHIHAN M S	/	/	/	/	A	/	/	/	/	A
25	NCAOEMT016	ANCE ANTONY	/	A	/	/	/	/	A	/	/	/
26	NCAOEMT022	BASIL T ABRAHAM	A	/	A	/	/	/	/	/	/	/
27	NCAOEMT025	ERSHINADH K KRISHNA	/	/	/	/	A	A	/	/	/	/
28	NCAOEMT026	FEMINA SHIREEN A	/	/	/	/	/	/	/	A	/	A

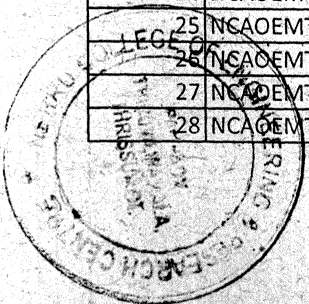

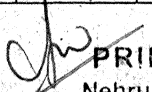

  
**PRINCIPAL**  
 Nehru College of  
 Engineering and Research Centre  
 Pampady Thiruvilwamala Thrissur Dt  
 Pin 680 507 Kerala

29	NCAOEMT032	ISHAN HUSSAIN KALAKKAT	A	/	/	/	A	/	/	/	/	/
30	NCAOEMT038	JINU P M	/	/	/	/	/	/	A	/	/	A
31	NCAOEMT041	KAKKAT ALI IBRAHIM	/	A	/	A	A	/	/	/	/	/
32	NCAOEMT042	MOHAMMED NIBRAS YOOSUF K	A	/	/	/	/	/	/	A	/	/
33	NCAOEMT048	SAFVAN	/	/	/	/	/	/	/	/	/	/
34	NCAOEMT049	SAJITH V	/	/	A	/	/	/	/	/	/	/
35	NCAOEMT054	SHINILNATH	/	/	/	/	/	/	A	/	/	/
36	NCAOEMT055	SIDHARTH N PISHARQDY	/	/	/	/	/	/	/	A	/	/
37	NCE15MC001	ABHIJITH DINESH	/	A	/	/	/	/	/	/	/	/
38	NCE15MC002	ABIJITH U K	/	/	/	/	A	/	/	/	/	/
39	NCE15MC005	AJAY ANAND C	/	/	A	/	/	/	/	/	/	/
40	NCE15MC006	AKASH A	/	/	/	/	/	/	A	/	/	A
41	NCE15MC007	AKHIL CHAND P P	A	/	/	/	/	/	/	A	/	/
42	NCE15MC010	ALIND ROY	/	/	/	A	/	/	/	/	/	/
43	NCE15MC011	AMARJITH VINOD	/	/	/	/	/	A	/	/	A	/
44	NCE15MC012	ANTONY SEBASTIAN KACHAPALLY	/	/	/	/	/	/	/	A	/	/
45	NCE15MC017	ATHUL VAISHNAV C	/	/	A	/	/	A	/	/	/	/
46	NCE15MC024	HARIHARAN C G	/	A	/	/	/	/	/	/	/	A
47	NCE15MC027	JITHIN T J	/	/	/	/	/	/	A	A	/	/
48	NCE15MC028	JOHNSON K JOSE	/	/	/	/	A	/	/	/	/	/
49	NCE15MC033	KENES CHRIS	/	A	/	/	/	/	/	/	/	/
50	NCE15MC034	KIRAN GEORGE	/	/	/	A	/	/	A	/	/	/
51	NCE15MC038	MOHAMED SHAROOK KHAN	/	/	A	/	/	/	/	/	/	A
52	NCE15MC040	MOHAMMED SUHAIL T.S	A	/	/	/	/	/	A	/	/	/
53	NCE15MC046	RESHMA S	/	/	/	/	/	A	/	/	A	/
54	NCE15MC052	SARUN R KUMAR	/	/	A	/	A	/	/	/	/	/
55	NCE15MC053	SPENCER DAVID	/	A	/	/	/	/	/	/	A	/
56	NCE15MC054	SREEJITH S	A	/	/	/	A	/	/	/	/	/

  
PROGRAM COORDINATOR

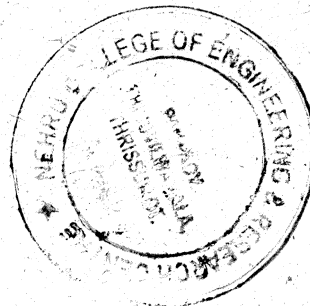
  
HOD



  
PRINCIPAL  
Nehru College of  
Engineering and Research Centre  
Pampady Thiruvikramala, Thrissur District  
Pin - 680 597 Kerala

**NEHRU COLLEGE OF ENGINEERING & RESEARCH CENTRE**

Pampady, Thiruvilwamala, Thrissur Dt.

**DEPARTMENT OF MECHATRONICS ENGINEERING**

**HEAT AND MASS TRANSFER**

Attendance Sheet

SL. NO.	REG. NO.	NAME OF STUDENT	13/9/15	17/9/15	19/9/15	20/9/15	20/9/15	26/9/15	26/9/15	31/10/15	31/10/15	4/11/15
1	NCANEMT002	ADITHYA SURESH	/	/	/	/	/	/	/	/	/	/
2	NCANEMT003	AKARSH S	A	/	/	/	/	/	/	/	/	/
3	NCANEMT005	AKSHAY M	/	A	/	/	/	/	/	/	A	/
4	NCANEMT006	ALOSHIOUS M DASAN	/	/	/	/	/	/	A	/	/	/
5	NCANEMT008	ANARGH VISWANATH	A	/	/	/	A	/	/	/	/	/
6	NCANEMT010	ANEESH K A	/	/	A	/	/	/	/	A	/	/
7	NCANEMT014	ARJUN P MENON	/	/	/	/	/	/	/	/	/	/
8	NCANEMT015	ARJUN VYSAKH C	A	/	A	/	/	/	/	/	/	A
9	NCANEMT017	ASHWIN K J	/	/	/	/	A	A	/	/	/	/
10	NCANEMT018	ASHWIN VARGHESE	/	A	/	/	/	/	/	/	/	/
11	NCANEMT022	CIBIN JOHN JOSEPH	/	/	/	/	/	/	A	/	/	/
12	NCANEMT023	DINILKUMAR K	/	A	/	/	/	/	/	/	/	/
13	NCANEMT027	HARIKRISHNAN P	/	/	/	A	/	/	/	/	A	/
14	NCANEMT028	IRSHAD MOHAMED GHANI	/	A	/	/	/	/	/	/	/	/
15	NCANEMT031	JITHU J	/	/	/	/	/	/	/	/	/	/
16	NCANEMT032	JYOTHISH M N	/	/	/	A	/	/	/	/	A	/
17	NCANEMT035	MOHAMMED SHIHAS K	A	/	/	/	/	/	/	/	/	/
18	NCANEMT039	PRAVEEN PRAKASH	/	/	/	/	/	/	/	/	/	/
19	NCANEMT042	RIDUL RAZWIN M R	/	/	A	/	/	A	/	/	/	/
20	NCANEMT045	SHAHSAD M	/	/	/	/	/	/	/	/	/	A
21	NCANEMT050	VISHNUDAS M	/	A	/	/	/	/	/	/	/	/
22	NCANEMT051	VISHNU PRASAD	/	/	/	/	A	/	A	/	/	/
23	NCAOEMT011	ALEN BABY	/	/	/	A	/	/	/	/	/	/
24	NCAOEMT012	ALISHIHAN M S	/	/	/	/	/	/	/	/	/	/
25	NCAOEMT016	ANCE ANTONY	/	/	/	/	/	/	/	A	/	/
26	NCAOEMT022	BASIL T ABRAHAM	/	/	/	/	A	/	/	/	/	/
27	NCAOEMT025	ERSHINADH K KRISHNA	A	/	/	/	/	/	/	/	/	A
28	NCAOEMT026	FEMINA SHIREEN A	/	/	/	/	/	/	A	A	/	/

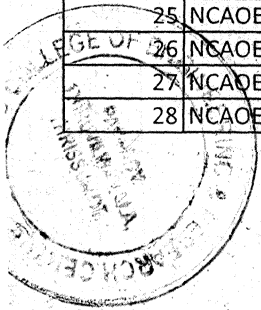

*Handwritten signature*

**PRINCIPAL**  
Nehru College of  
Engineering and Research Centre  
Pampady, Thiruvilwamala, Thrissur Dt.  
Pin 680 597 Kerala

29	NCAOEMT032	ISHAN HUSSAIN KALAKKAT	/	A	/	/	/	/	/	/	/	/
30	NCAOEMT038	JINU P M	/	/	/	A	/	/	/	/	/	/
31	NCAOEMT041	KAKKAT ALI IBRAHIM	/	/	/	/	/	A	/	/	/	/
32	NCAOEMT042	MOHAMMED NIBRAS YOOSUF K	/	/	/	/	A	/	/	/	/	/
33	NCAOEMT048	SAFVAN	/	/	/	/	/	/	/	A	/	/
34	NCAOEMT049	SAJITH V	/	/	/	A	/	/	/	/	/	/
35	NCAOEMT054	SHINILNATH	/	/	/	/	/	/	A	/	/	/
36	NCAOEMT055	SIDHARTH N PISHARODY	/	/	/	/	/	/	/	/	A	/
37	NCE15MC001	ABHIJITH DINESH	/	/	A	/	/	/	/	/	/	/
38	NCE15MC002	ABIJITH U K	/	/	/	/	/	/	/	/	/	A
39	NCE15MC005	AJAY ANAND C	/	A	/	/	/	/	/	/	/	/
40	NCE15MC006	AKASH A	/	/	/	/	/	A	/	/	/	/
41	NCE15MC007	AKHIL CHAND P P	/	/	/	/	/	/	/	A	/	/
42	NCE15MC010	ALIND ROY	/	/	/	A	/	/	/	/	/	/
43	NCE15MC011	AMARJITH VINOD	A	/	/	/	/	/	/	/	/	/
44	NCE15MC012	ANTONY SEBASTIAN KACHAPALLY	/	/	/	/	/	/	/	/	A	/
45	NCE15MC017	ATHUL VAISHNAV C	/	/	A	/	/	/	/	/	/	/
46	NCE15MC024	HARIHARAN C G	/	/	/	/	/	/	/	/	/	A
47	NCE15MC027	JITHIN T J	/	A	/	/	/	/	/	/	/	/
48	NCE15MC028	JOHNSON K JOSE	/	/	/	/	A	/	/	/	/	/
49	NCE15MC033	KENES CHRIS	/	/	/	/	/	/	A	/	/	/
50	NCE15MC034	KIRAN GEORGE	A	/	/	/	/	/	/	/	/	/
51	NCE15MC038	MOHAMED SHAROOK KHAN	/	A	/	/	/	/	/	A	/	/
52	NCE15MC040	MOHAMMED SUHAIL T S	/	/	/	/	/	/	/	/	/	A
53	NCE15MC046	RESHMA S	/	/	/	/	/	A	/	/	/	/
54	NCE15MC052	SARUN R KUMAR	/	/	/	A	/	/	/	/	/	/
55	NCE15MC053	SPENCER DAVID	/	A	/	/	/	/	/	/	/	/
56	NCE15MC054	SREEJITH S	A	/	/	/	/	/	/	/	/	/

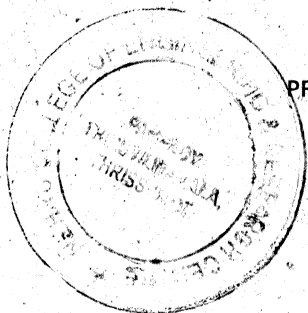

PROGRAM COORDINATOR

*[Signature]*  
HOD

*[Signature]*  
PRINCIPAL  
Nehru College of  
Engineering and Research Centre  
Pampady Thiruvilwamala, Thrissur Dt  
Pm 680 597 Kerala

29	NCAOEMT032	ISHAN HUSSAIN KALAKKAT	/	A	/	/	/	/	/	/	/	/
30	NCAOEMT038	JINU P M	/	/	/	A	/	/	/	/	/	/
31	NCAOEMT041	KAKKAT ALI IBRAHIM	/	/	/	/	/	A	/	/	/	/
32	NCAOEMT042	MOHAMMED NIBRAS YOOSUF K	/	/	/	/	A	/	/	/	/	/
33	NCAOEMT048	SAFVAN	/	/	/	/	/	/	A	/	/	/
34	NCAOEMT049	SAJITH V	/	/	/	A	/	/	/	/	/	/
35	NCAOEMT054	SHINILNATH	/	/	/	/	/	/	A	/	/	/
36	NCAOEMT055	SIDHARTH N PISHARODY	/	/	/	/	/	/	/	A	/	/
37	NCE15MC001	ABHIJITH DINESH	/	/	A	/	/	/	/	/	/	/
38	NCE15MC002	ABIJITH U K	/	/	/	/	/	/	/	/	/	A
39	NCE15MC005	AJAY ANAND C	/	A	/	/	/	/	/	/	/	/
40	NCE15MC006	AKASH A	/	/	/	/	/	A	/	/	/	/
41	NCE15MC007	AKHIL CHAND P P	/	/	/	/	/	/	A	/	/	/
42	NCE15MC010	ALIND ROY	/	/	/	A	/	/	/	/	/	/
43	NCE15MC011	AMARJITH VINOD	A	/	/	/	/	/	/	/	/	/
44	NCE15MC012	ANTONY SEBASTIAN KACHAPALLY	/	/	/	/	/	/	/	A	/	/
45	NCE15MC017	ATHUL VAISHNAV C	/	/	A	/	/	/	/	/	/	/
46	NCE15MC024	HARIHARAN C G	/	/	/	/	/	/	/	/	/	A
47	NCE15MC027	JITHIN T J	/	A	/	/	/	/	/	/	/	/
48	NCE15MC028	JOHNSON K JOSE	/	/	/	/	A	/	/	/	/	/
49	NCE15MC033	KENES CHRIS	/	/	/	/	/	/	A	/	/	/
50	NCE15MC034	KIRAN GEORGE	A	/	/	/	/	/	/	/	/	/
51	NCE15MC038	MOHAMED SHAROOK KHAN	/	A	/	/	/	/	/	A	/	/
52	NCE15MC040	MOHAMMED SUHAIL T S	/	/	/	/	/	/	/	/	/	A
53	NCE15MC046	RESHMA S	/	/	/	/	/	A	/	/	/	/
54	NCE15MC052	SARUN R KUMAR	/	/	/	A	/	/	/	/	/	/
55	NCE15MC053	SPENCER DAVID	/	A	/	/	/	/	/	/	/	/
56	NCE15MC054	SREEJITH S	A	/	/	/	/	/	/	/	/	/

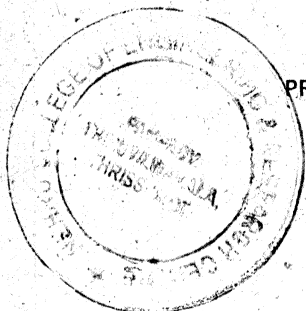

PROGRAM COORDINATOR

HOD

PRINCIPAL  
Nehru College of  
Engineering and Research Centre  
Pampady, Thiruvilwamala, Thrissur, Kerala  
Pin - 680 597 Kerala

**NEHRU COLLEGE OF ENGINEERING & RESEARCH CENTRE**

Pampady, Thiruvilwamala, Thrissur Dt.

**DEPARTMENT OF MECHATRONICS ENGINEERING**

**HEAT AND MASS TRANSFER**

**Attendance Sheet**

SL. NO.	REG. NO.	NAME OF STUDENT	10/10/15	11/10/15	11/10/15	17/10/15	17/10/15	18/10/15	18/10/15	31/10/15	31/10/15	7/11/15
1	NCANEMT002	ADITHYA SURESH	/	/	/	/	/	/	/	/	/	A
2	NCANEMT003	AKARSH S	/	A	/	/	/	/	/	/	/	/
3	NCANEMT005	AKSHAY M	/	/	/	/	/	/	/	/	A	/
4	NCANEMT006	ALOSHIOUS M DASAN	/	/	A	/	/	/	/	/	/	/
5	NCANEMT008	ANARGH VISWANATH	/	/	/	/	/	/	/	A	/	/
6	NCANEMT010	ANEESH K A	/	/	/	/	/	/	/	A	/	/
7	NCANEMT014	ARJUN P MENON	/	/	/	/	/	/	A	/	/	/
8	NCANEMT015	ARJUN VYSAKH C	/	/	/	/	A	/	/	/	/	/
9	NCANEMT017	ASHWIN K J	/	/	/	/	/	/	/	/	/	A
10	NCANEMT018	ASHWIN VARGHESE	/	/	/	A	/	/	/	/	/	/
11	NCANEMT022	CIBIN JOHN JOSEPH	/	/	/	/	/	A	/	/	/	/
12	NCANEMT023	DINILKUMAR K	/	/	/	A	/	/	/	/	/	/
13	NCANEMT027	HARIKRISHNAN P	/	A	/	/	/	/	/	/	/	/
14	NCANEMT028	IRSHAD MOHAMED GHANI	/	/	A	/	/	/	/	/	/	/
15	NCANEMT031	JITHU J	A	/	/	/	/	/	/	/	A	/
16	NCANEMT032	JYOTHISH M N	/	/	/	/	/	/	/	/	/	A
17	NCANEMT035	MOHAMMED SHIHAS K	/	/	/	/	/	/	A	/	/	/
18	NCANEMT039	PRAVEEN PRAKASH	/	/	/	A	/	/	/	/	/	/
19	NCANEMT042	RIDUL RAZWIN M R	/	/	A	/	/	A	/	/	/	/
20	NCANEMT045	SHAHSAD M	/	/	/	/	/	/	/	/	/	/
21	NCANEMT050	VISHNUDAS M	/	/	/	/	A	/	/	/	/	/
22	NCANEMT051	VISHNU PRASAD	A	/	/	/	/	/	/	/	/	/
23	NCAOEMT011	ALEN BABY	/	/	/	A	/	/	/	/	/	/
24	NCAOEMT012	ALISHIHAN M S	/	/	/	A	/	/	/	/	/	/
25	NCAOEMT016	ANCE ANTONY	/	/	/	/	/	/	/	A	/	/
26	NCAOEMT022	BASIL T ABRAHAM	/	/	A	/	/	/	/	/	/	/
27	NCAOEMT025	ERSHINADH K KRISHNA	/	/	/	/	/	/	/	/	/	A
28	NCAOEMT026	FEMINA SHIREEN A	A	/	/	/	/	/	/	/	/	/

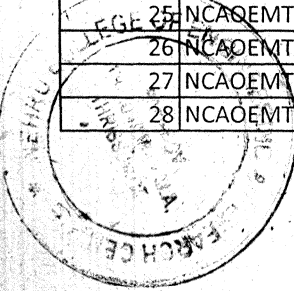

  
**PRINCIPAL**  
 Nehru College of  
 Engineering and Research Centre  
 Pampady, Thiruvilwamala, Thrissur  
 Pin - 680 597 Kerala

29	NCAOEMT032	ISHAN HUSSAIN KALAKKAT	A	/	/	/	/	/	/	A	/	/
30	NCAOEMT038	JINU P M	/	/	A	/	/	/	/	/	/	A
31	NCAOEMT041	KAKKAT ALI IBRAHIM	/	A	/	/	/	/	A	/	/	/
32	NCAOEMT042	MOHAMMED NIBRAS YOOSUF K	/	/	/	/	A	/	/	/	/	/
33	NCAOEMT048	SAFVAN	/	/	A	/	/	/	/	A	/	/
34	NCAOEMT049	SAJITH V	/	/	/	/	/	A	/	/	/	A
35	NCAOEMT054	SHINILNATH	/	A	/	/	A	/	/	/	/	/
36	NCAOEMT055	SIDHARTH N PISHARODY	/	/	/	/	/	/	A	/	/	/
37	NCE15MC001	ABHIJITH DINESH	A	/	/	/	A	/	/	/	/	/
38	NCE15MC002	ABIJITH U K	/	/	/	/	A	/	/	/	/	A
39	NCE15MC005	AJAY ANAND C	/	/	/	/	/	/	/	/	/	/
40	NCE15MC006	AKASH A	/	A	/	/	/	/	/	/	/	/
41	NCE15MC007	AKHIL CHAND P P	/	A	/	/	/	/	/	/	/	/
42	NCE15MC010	ALIND ROY	/	A	/	/	/	/	/	/	/	/
43	NCE15MC011	AMARJITH VINOD	/	/	/	/	/	A	/	/	/	/
44	NCE15MC012	ANTONY SEBASTIAN KACHAPALLY	/	/	A	/	/	/	/	/	/	A
45	NCE15MC017	ATHUL VAISHNAV C	/	/	/	A	/	/	/	/	/	/
46	NCE15MC024	HARIHARAN C G	/	/	/	A	/	/	/	A	/	/
47	NCE15MC027	JITHIN T J	A	/	/	/	/	/	/	/	/	/
48	NCE15MC028	JOHNSON K JOSE	/	/	/	/	/	A	/	/	/	/
49	NCE15MC033	KENES CHRIS	/	/	/	/	A	/	/	/	/	/
50	NCE15MC034	KIRAN GEORGE	/	/	A	/	/	/	/	/	/	/
51	NCE15MC038	MOHAMED SHAROOK KHAN	/	A	/	/	/	/	/	/	/	A
52	NCE15MC040	MOHAMMED SUHAIL T S	/	/	/	/	/	/	/	/	A	/
53	NCE15MC046	RESHMA S	/	/	/	/	/	/	A	/	/	/
54	NCE15MC052	SARUN R KUMAR	/	/	/	/	A	/	/	/	/	/
55	NCE15MC053	SPENCER DAVID	/	/	A	/	/	/	/	/	/	A
56	NCE15MC054	SREEJITH S	A	/	/	/	/	/	/	A	/	/

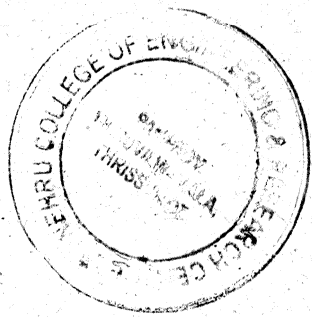

PROGRAM COORDINATOR

HOD

PRINCIPAL  
Nehru College of  
Engineering and Research Centre  
Pampady, Poojappara, Thrissur Dt  
Pin - 680 597 Kerala



**NEHRU COLLEGE OF ENGINEERING AND RESEARCH CENTRE**  
**(NAAC Accredited)**

(Approved by AICTE, Affiliated to APJ Abdul Kalam Technological University, Kerala)  
**ADD ON COURSE ANSWER KEY**



**HEAT AND MASS TRANSFER**

1. C
2. A
3. B
4. D
5. A
6. C
7. B
8. D
9. A
10. B
11. D
12. B
13. D
14. C
15. B
16. C
17. D
18. D
19. B
20. D
21. B
22. A
23. C
24. D
25. A
26. B
27. A
28. C
29. B
30. D
31. D
32. A
33. C
34. B
35. D
36. B

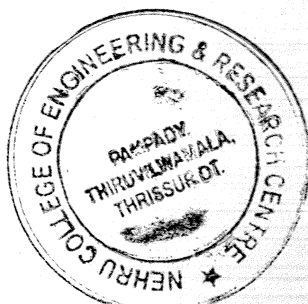

  
**PRINCIPAL**  
Nehru College of

Engineering and Research Centre  
Pampady, Thiruvilwamala, Thriassur Dt.  
Pin 680 597 Kerala

- 37. A
- 38. C
- 39. D
- 40. B
- 41. B
- 42. A
- 43. D
- 44. C
- 45. B
- 46. A
- 47. D
- 48. C
- 49. A
- 50. D

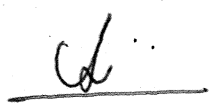

  
PRINCIPAL  
Nehru College of  
Engineering and Research Centre  
Pampady, Thiruvilwamala, Thrissur Dt  
Pin 680 597 Kerala

Antony Sebastian K.  
NCE15 MCO12

16  
100



NEHRU COLLEGE OF ENGINEERING AND RESEARCH CENTRE  
(NAAC Accredited)

(Approved by AICTE, Affiliated to APJ Abdul Kalam Technological University, Kerala)

CERTIFICATION COURSE QUESTION PAPER



HEAT AND MASS TRANSFER

1. The literature of heat transfer generally recognizes distinct modes of heat transfer. How many modes are there?

- a) One
- b) Two
- c) Three ✓
- d) Four

2. Consider system A at uniform temperature  $t$  and system B at another uniform temperature  $T$  ( $t > T$ ). Let the two systems be brought into contact and be thermally insulated from their surroundings but not from each other. Energy will flow from system A to system B because of

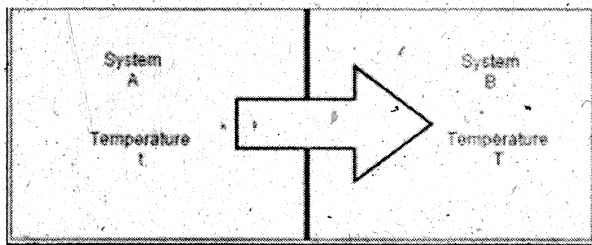

- a) Temperature difference
- b) Energy difference
- c) Mass difference
- d) Volumetric difference ✓

3. An oil cooler in a high performance engine has an outside surface area  $0.12 \text{ m}^2$  and a surface temperature of  $65 \text{ degree Celsius}$ . At any intermediate time air moves over the surface of the cooler at a temperature of  $30 \text{ degree Celsius}$  and gives rise to a surface coefficient equal to  $45.4 \text{ W/m}^2 \text{ K}$ . Find out the heat transfer rate?

- a)  $238.43 \text{ W}$
- b)  $190.68 \text{ W}$
- c)  $543.67 \text{ W}$
- d)  $675.98 \text{ W}$  ✓

4. Unit of the rate of heat transfer is

- a) Joule ✓
- b) Newton
- c) Pascal
- d) Watt

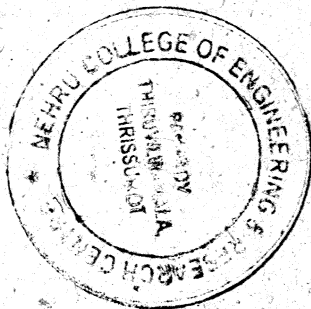

PRINCIPAL  
Nehru College of  
Engineering and Research Centre  
Pampady, Thiruvilwamala, Thrissur Dt  
Pin - 680 507

5. Convective heat transfer coefficient doesn't depend on

- a) Surface area
- b) Space
- c) Time
- d) Orientation of solid surface ✓

6. The rate equation used to describe the mechanism of convection is called Newton's law of cooling. So rate of heat flow by convection doesn't depend on

- a) Convective heat transfer coefficient
- b) Surface area through which heat flows
- c) Time
- d) Temperature potential difference ✓

7. How many types of convection process are there?

- a) One
- b) Three
- c) Four
- d) Two ✓

8. Thermal conductivity is maximum for which substance

- a) Silver ✓
- b) Ice
- c) Aluminum
- d) Diamond

9. A radiator in a domestic heating system operates at a surface temperature of 60 degree Celsius. Calculate the heat flux at the surface of the radiator if it behaves as a black body

- a) 697.2 W/m<sup>2</sup> ✓
- b) 786.9 W/m<sup>2</sup>
- c) 324.7 W/m<sup>2</sup>
- d) 592.1 W/m<sup>2</sup>

View Answer

10. Which of the following is an example of forced convection?

- a) Chilling effect of cold wind on a warm body
- b) Flow of water in condenser tubes
- c) Cooling of billets in the atmosphere
- d) Heat exchange on cold and warm pipes ✓

11. Regarding one dimensional heat transfer, choose the correct statement

- a) Steady-  $f(x)$ , Unsteady-  $f(x, t)$  ✓
- b) Steady-  $f(x, t)$ , Unsteady-  $f(x)$
- c) Steady-  $f(x, y, t)$ , Unsteady-  $f(x)$

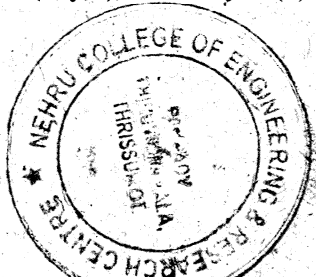

PRINCIPAL  
Nehru College of  
Engineering and Research Centre  
Pattipady, Thiruvananthapuram, Thiruvananthapuram Dt  
Pin - 680 597, Kerala

d) Steady-  $f(y, z)$ , Unsteady-  $f(y)$

12. Which statement is true regarding steady state condition?

- a) There is a variation in temperature in the course of time ✓
- b) Heat exchange is constant ✗
- c) It is a function of space and time coordinates
- d) Internal energy of the system changes

13. Which of the following is an example of steady state heat transfer?

- a) Boilers and turbines ✓
- b) Cooling of I.C engine ✓
- c) Chilling effect of cold wind on a warm body
- d) Electric bulb cools down by the surrounding atmosphere ✓

14. Heat transfer in a long, hollow cylinder which is maintained at uniform but different temperatures on its inner and outer surfaces may be assumed to be taking place in which direction?

- a) Axial only
- b) Unpredictable ✗
- c) Radial only
- d) No heat transfer takes place ✓

15. Heat transfer takes place according to which law?

- a) Newton's law of cooling
- b) Second law of thermodynamics ✗
- c) Newton's second law of motion
- d) First law of thermodynamics ✓

16. Heat transfer takes place in liquids and gases is essentially due to

- a) Radiation
- b) Conduction
- c) Convection ✗
- d) Conduction as well as convection ✓

17. The appropriate rate equation for convective heat transfer between a surface and adjacent fluid is prescribed by

- a) Newton's first law ✓
- b) Wein's displacement law ✗

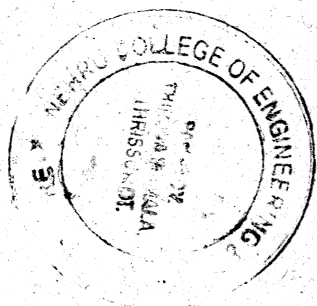

PRINCIPAL

Nehru College of  
Engineering and Research Centre  
Panipady Thiruvilwamala, Thiruvananthapuram  
Pin: 686 401, Kerala

- c) Kirchhoff's law
- d) Newton's law of cooling

18. Identify the wrong statement

- a) The process of heat transfer is an irreversible process
- b) For heat exchange, a temperature gradient must exist
- c) A material medium is not necessary for heat transmission
- d) Heat flow doesn't depend on temperature

19. During a cold winter season, a person prefers to sit near a fire. Which of the following modes of heat transfer provides him the maximum heat?

- a) Conduction from the fire
- b) If it is near the fire, convection sounds good
- c) Convection and radiation together
- d) Radiation will provide quick warmth

20. Most unsteady heat flow occurs

- a) Through the walls of the refrigerator
- b) During annealing of castings
- c) Through the walls of the furnace
- d) Through lagged pipe carrying steam

21. The famous Fourier series is named after

- a) Diller and Ryan
- b) J.B. Joseph Fourier
- c) Stefan- Boltzmann
- d) Wein's

22. Fourier law of heat conduction is best represented by

- a)  $Q = -k A d t / d x$
- b)  $Q = k A d x / d t$
- c)  $Q = -k A$
- d)  $Q = k d t / d x$

23. Here are some assumptions that are made for Fourier law. Identify the wrong one

- a) No internal heat generation
- b) Steady state heat conduction
- c) Non- linear temperature profile
- d) Isotropic and homogenous material



  
PRINCIPAL  
Nehru College of  
Engineering and Research Center  
Pampady, Thiruvallur, Thiruvallur Dt  
Pin 680 597, Kerala

24. Consider the following statements:

The Fourier heat conduction equation

$$Q = -k A \frac{dt}{dx}$$

Presumes

- i) Steady state conditions
- ii) Constant value of thermal conductivity
- iii) Uniform temperature at the wall surface
- iv) One dimensional heat flow

Which of these statements are correct?

- a) i, ii and iii ✓
- b) i, ii and iv
- c) i, iii and iv
- d) i, iii and iv

25. The diagram shows heat conduction through a plane wall. The surface temperature is 475 K and it radiates heat to the surroundings at 335 K. If thermal conductivity of the material is 12.5 W/m degree. find the temperature gradient. Let convective coefficient be 80 W/m<sup>2</sup> degree and radiation factor is 0.9

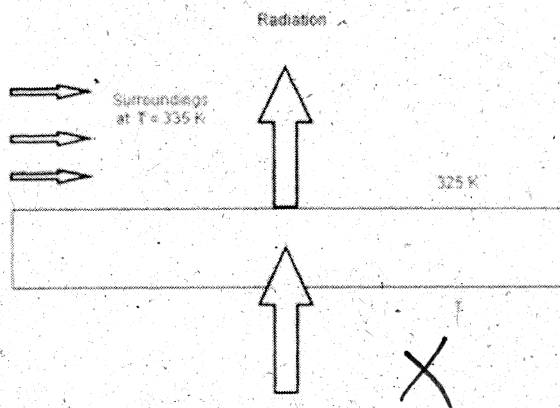

- a) - 1052.4 degree celsius
- b) - 2052.4 degree celsius
- c) - 3052.4 degree celsius
- d) - 4052.4 degree celsius ✓

26. Negative sign in Fourier heat conduction equation indicates

- a) Heat always flow is in the direction of positive temperature gradient
- b) Heat always flow in the direction of negative temperature gradient ✓
- c) No heat flow is there
- d) Data is insufficient

27. Transmission of heat i.e. molecular is smallest in case of

- a) Gases
- b) Liquids
- c) Alloys ✓

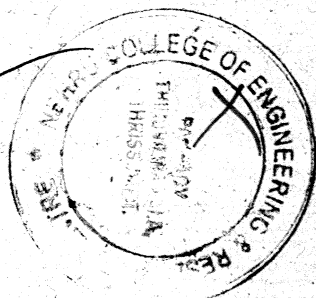

  
PRINCIPAL  
Nehru College of  
Engineering and Research Centre  
Warananasi, Warananasi, Warananasi

d) Solids

28. Which one is not the unit of thermal conductivity?

- a) kcal/m hr K
- b) KJ/m hr K
- c) W/m s K ✓
- d) Cal/cm s K

29. "Thermal conductivity represents the amount of heat conducted across the unit area when a temperature difference of one kelvin".

- a) True ✓
- b) False

30. Which of the following is the unit of thermal resistance?

- a) degree/kcal ✓
- b) hour degree
- c) s degree/kcal
- d) degree/W

31. Thermal conductivity is defined as the heat flow per unit time

- a) When the temperature gradient is unity ✓
- b) Across the wall with no temperature
- c) Through a unit thickness of the wall
- d) Across unit area where the temperature gradient is unity

32. Mark the matter with least value of thermal conductivity

- a) Air
- b) Water
- c) Ash
- d) Window glass ✓

33. Which one of the following forms of water have the highest value of thermal conductivity?

- a) Boiling water ✓
- b) Steam
- c) Solid ice
- d) Melting ice

34. The average thermal conductivities of water and air conform to the ratio

- a) 50:1 ✓

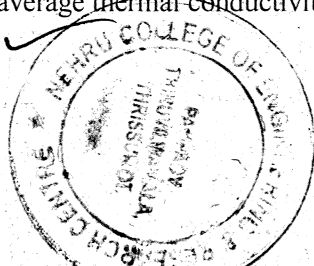

PRINCIPAL  
Nehru College of  
Engineering and Research Center  
Pampady Thiruvilwamala, Thiruvananthapuram  
Pin 680 597 Kerala

- b) 25:1
- c) 5:1
- d) 15:1

X

35. Identify the very good insulator

- a) Saw dust ✓
- b) Cork
- c) Asbestos sheet X
- d) Glass wool

36. Most metals are good conductor of heat because of

- a) Transport of energy
- b) Free electrons and frequent collision of atoms X
- c) Lattice defects
- d) Capacity to absorb energy ✓

37. Heat conduction in gases is due to

- a) Elastic impact of molecules ✓
- b) Movement of electrons ✓
- c) EM Waves
- d) Mixing of gases

38. The heat energy propagation due to conduction heat transfer will be minimum for

- a) Lead ✓
- b) Water
- c) Air X
- d) Copper

39. Cork is a good insulator because

- a) It is flexible ✓
- b) It can be powdered X
- c) Low density
- d) It is porous

40. Choose the false statement

- a) For pure metal thermal conductivity is more ✓
- b) Thermal conductivity decreases with increase in the density of the substance
- c) Thermal conductivity of dry material is lower than that of damp material
- d) Heat treatment causes variation in thermal conductivity

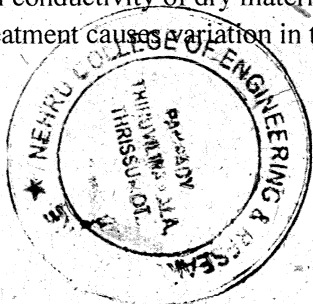

X

Signature

PRINCIPAL  
Nehru College of  
Engineering and Research Centre  
Pan-pady Thiruvithiyamala Thiruvananthapuram

41. From the concept of kinetic theory, mean travel velocity of the gas molecules is prescribed by the relation

- a)  $V = (3M/GT)^{1/2}$
- b)  $V = (3GT/M)^{1/2}$
- c)  $V = (6T/GM)^{1/2}$
- d)  $V = (3GT/2M)^{1/2}$  ✓

42. Low temperature insulation are used when the enclosure is at a temperature lower than the ambient temperature. Which one of the following is not a low temperature insulation?

- a) Asbestos
- b) Cork
- c) Cattle hair
- d) Slag wool ✓

43. The value of Lorenz number in  $10^{-8} \text{ W ohms/K}^2$  is

- a) 2.02
- b) 2.35
- c) 2.56
- d) 2.45 ✓

44. For liquids, thermal conductivity is governed by the relation

- a)  $k = A c_p p^{7/3} / M^{1/3}$
- b)  $k = 2A c_p p^{4/3} / M^{2/3}$
- c)  $k = A c_p p^{4/3} / M^{1/3}$
- d)  $k = A c_p p^{8/3} / M^{1/3}$  ✓

45. Consider the following parameters

- (i) Composition
- (ii) Density
- (iii) Porosity
- (iv) Structure ✓

Then, thermal conductivity of glass wool varies from sample to sample because of variation is.

- a) i and ii
- b) i, ii, iii and iv
- c) i and iii
- d) i, ii and iii ✓

46. The thermal conductivity and the electrical conductivity of a metal at absolute temperature are related as

- a)  $k/\sigma T$
- b)  $k/\sigma$  ✓

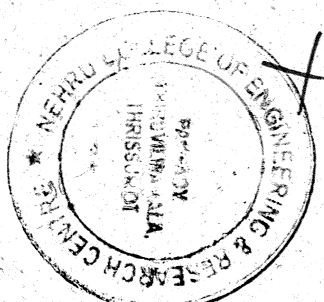

- c)  $k \sigma/T$
- d)  $k/T$

47. The relation  $\nabla^2 t = 0$  is referred to as

- a) Poisson's equation ✓
- b) Fourier heat conduction equation ✗
- c) Solution for transient conduction
- d) Laplace equation

48. The unit of thermal diffusivity is

- a)  $m^2/hr-K$  ✓
- b)  $kcal/m^2-hr$
- c)  $m^2/hr$  ✗
- d)  $m/hr-K$

49. To effect a bond between two metal plates, 2.5 cm and 15 cm thick, heat is uniformly applied through the thinner plate by a radiant heat source. The bonding must be held at 320 K for a short time. When the heat source is adjusted to have a steady value of  $43.5 \text{ k W/m}^2$ , a thermocouple installed on the side of the thinner plate next to source indicates a temperature of 345 K. Calculate the temperature gradient for heat conduction through thinner plate. In the diagram, the upper plate is 2.5 cm thick while the lower is 15 cm thick.

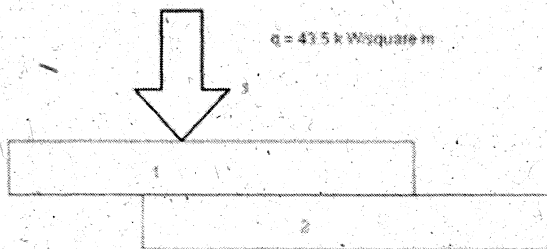

- a) - 1000 degree Celsius/m ✗
- b) - 2000 degree Celsius/m
- c) - 3000 degree Celsius/m
- d) - 4000 degree Celsius/m ✓

50. The diffusion equations

$$\nabla^2 t + q_g = (1/\alpha) (d t/d t)$$

Governs the temperature distribution under unsteady heat flow through a homogeneous and isotropic material. The Fourier equation follows from this expression when

- a) Temperature doesn't depends on time ✓
- b) There is no internal heat generation ✗
- c) Steady state conditions prevail
- d) There is no internal heat generation but unsteady state condition prevails

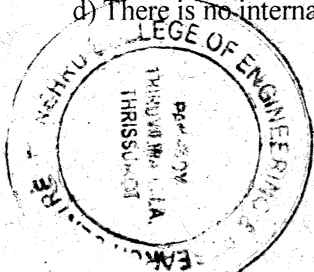

PRINCIPAL  
Nehru College of  
Engineering and Research Centre  
Panapady, Thiruvilwamala, Thrissur

Arjun Vysakh.C  
NCANEMT015

64  
100



NEHRU COLLEGE OF ENGINEERING AND RESEARCH CENTRE  
(NAAC Accredited)  
(Approved by AICTE, Affiliated to APJ Abdul Kalam Technological University, Kerala)  
CERTIFICATION COURSE QUESTION PAPER



## HEAT AND MASS TRANSFER

1. The literature of heat transfer generally recognizes distinct modes of heat transfer. How many modes are there?

- a) One ✓
- b) Two ✗
- c) Three
- d) Four

2. Consider system A at uniform temperature  $t$  and system B at another uniform temperature  $T$  ( $t > T$ ). Let the two systems be brought into contact and be thermally insulated from their surroundings but not from each other. Energy will flow from system A to system B because of

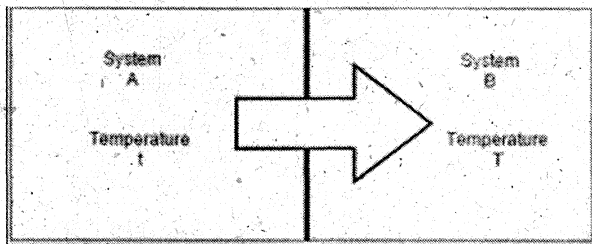

- a) Temperature difference ✓
- b) Energy difference
- c) Mass difference
- d) Volumetric difference

3. An oil cooler in a high performance engine has an outside surface area  $0.12 \text{ m}^2$  and a surface temperature of  $65 \text{ degree Celsius}$ . At any intermediate time air moves over the surface of the cooler at a temperature of  $30 \text{ degree Celsius}$  and gives rise to a surface coefficient equal to  $45.4 \text{ W/m}^2 \text{ K}$ . Find out the heat transfer rate?

- a)  $238.43 \text{ W}$
- b)  $190.68 \text{ W}$
- c)  $543.67 \text{ W}$
- d)  $675.98 \text{ W}$  ✓

4. Unit of the rate of heat transfer is

- a) Joule
- b) Newton
- c) Pascal
- d) Watt ✓

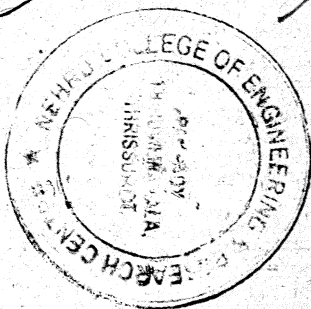

*Ch*

PRINCIPAL  
Nehru College of  
Engineering and Research Centre  
Panipady Thiruvilwamala, Thrissur District  
Pin 680 597 Kerala

5. Convective heat transfer coefficient doesn't depend on

- a) Surface area ✓
- b) Space ✓
- c) Time
- d) Orientation of solid surface

6. The rate equation used to describe the mechanism of convection is called Newton's law of cooling. So rate of heat flow by convection doesn't depend on

- a) Convective heat transfer coefficient
- b) Surface area through which heat flows ✓
- c) Time ✓
- d) Temperature potential difference

7. How many types of convection process are there?

- a) One
- b) Three ✓
- c) Four
- d) Two

8. Thermal conductivity is maximum for which substance

- a) Silver ✓
- b) Ice
- c) Aluminum
- d) Diamond

9. A radiator in a domestic heating system operates at a surface temperature of 60 degree Celsius. Calculate the heat flux at the surface of the radiator if it behaves as a black body

- a) 697.2 W/m<sup>2</sup>
- b) 786.9 W/m<sup>2</sup>
- c) 324.7 W/m<sup>2</sup>
- d) 592.1 W/m<sup>2</sup> ✓

View Answer

10. Which of the following is an example of forced convection?

- a) Chilling effect of cold wind on a warm body
- b) Flow of water in condenser tubes ✓
- c) Cooling of billets in the atmosphere
- d) Heat exchange on cold and warm pipes

11. Regarding one dimensional heat transfer, choose the correct statement

- a) Steady- f(x), Unsteady- f(x, t)
- b) Steady- f(x, t), Unsteady- f(x) ✓
- c) Steady- f(x, y, t), Unsteady- f(x)

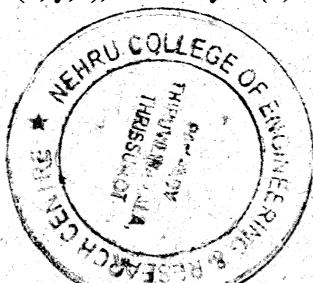

PRINCIPAL  
Nehru College of  
Engineering and Research Centre  
Panipady, Thiruvilwamala, Thrissur Dt  
Pin - 680 597 Kerala

d) Steady-  $f(y, z)$ , Unsteady-  $f(y)$  ✓

12. Which statement is true regarding steady state condition?

- a) There is a variation in temperature in the course of time
- b) Heat exchange is constant
- c) It is a function of space and time coordinates X
- d) Internal energy of the system changes ✓

13. Which of the following is an example of steady state heat transfer?

- a) Boilers and turbines ✓
- b) Cooling of I.C engine
- c) Chilling effect of cold wind on a warm body X
- d) Electric bulb cools down by the surrounding atmosphere

14. Heat transfer in a long, hollow cylinder which is maintained at uniform but different temperatures on its inner and outer surfaces may be assumed to be taking place in which direction?

- a) Axial only
- b) Unpredictable
- c) Radial only ✓
- d) No heat transfer takes place ✓

15. Heat transfer takes place according to which law?

- a) Newton's law of cooling
- b) Second law of thermodynamics
- c) Newton's second law of motion X
- d) First law of thermodynamics ✓

16. Heat transfer takes place in liquids and gases is essentially due to

- a) Radiation
- b) Conduction
- c) Convection ✓
- d) Conduction as well as convection ✓

17. The appropriate rate equation for convective heat transfer between a surface and adjacent fluid is prescribed by

- a) Newton's first law ✓
- b) Wein's displacement law X



PRINCIPAL  
Nehru College of  
Engineering and Research Centre  
Pampady Thiruvilwamala, Thrissur Dt  
Pin - 680 597 Kerala

- c) Kirchoff's law
- d) Newton's law of cooling

18. Identify the wrong statement

- a) The process of heat transfer is an irreversible process ✓
- b) For heat exchange, a temperature gradient must exist ✓
- c) A material medium is not necessary for heat transmission ✓
- d) Heat flow doesn't depend on temperature ✓

19. During a cold winter season, a person prefers to sit near a fire. Which of the following modes of heat transfer provides him the maximum heat?

- a) Conduction from the fire ✓
- b) If it is near the fire, convection sounds good ✓
- c) Convection and radiation together ✓
- d) Radiation will provide quick warmth ✓

20. Most unsteady heat flow occurs

- a) Through the walls of the refrigerator ✓
- b) During annealing of castings ✓
- c) Through the walls of the furnace ✓
- d) Through lagged pipe carrying steam ✓

21. The famous Fourier series is named after

- a) Diller and Ryan ✓
- b) J.B. Joseph Fourier ✓
- c) Stefan- Boltzmann ✓
- d) Wein's ✓

22. Fourier law of heat conduction is best represented by

- a)  $Q = -k A d t / d x$  ✓
- b)  $Q = k A d x / d t$  ✓
- c)  $Q = -k A$  ✓
- d)  $Q = k d t / d x$  ✓

23. Here are some assumptions that are made for Fourier law. Identify the wrong one

- a) No internal heat generation ✓
- b) Steady state heat conduction ✓
- c) Non- linear temperature profile ✓
- d) Isotropic and homogenous material ✓

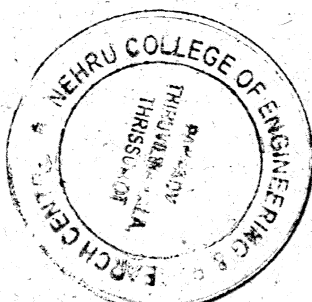

PRINCIPAL,  
Nehru College of  
Engineering and Research Centre  
Panpady, Thrissur Dt  
Kerala

24. Consider the following statements:

The Fourier heat conduction equation

$$Q = -k A \frac{dt}{dx}$$

Presumes

- i) Steady state conditions
- ii) Constant value of thermal conductivity
- iii) Uniform temperature at the wall surface
- iv) One dimensional heat flow

Which of these statements are correct?

a) i, ii and iii

b) i, ii and iv ✓

c) i, iii and iv

d) i, iii and iv

25. The diagram shows heat conduction through a plane wall. The surface temperature is 475 K and it radiates heat to the surroundings at 335 K. If thermal conductivity of the material is 12.5 W/m degree, find the temperature gradient. Let convective coefficient be 80 W/m<sup>2</sup> degree and radiation factor is 0.9

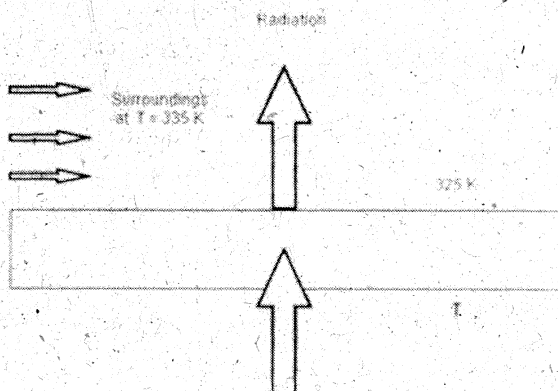

a) - 1052.4 degree celsius

b) - 2052.4 degree celsius

c) - 3052.4 degree celsius

d) - 4052.4 degree celsius ✓

26. Negative sign in Fourier heat conduction equation indicates

a) Heat always flow is in the direction of positive temperature gradient

b) Heat always flow in the direction of negative temperature gradient ✓

c) No heat flow is there

d) Data is insufficient

27. Transmission of heat i.e. molecular is smallest in case of

a) Gases ✓

b) Liquids

c) Alloys

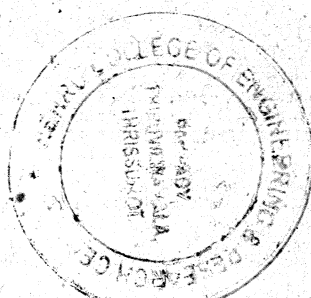

PRINCIPAL  
Nehru College of  
Engineering and Research Centre  
Panipady Thiruvilwamala, Thiruvananthapuram  
Pin - 680 597 Kerala

d) Solids

28. Which one is not the unit of thermal conductivity?

- a) kcal/m hr K
- b) KJ/m hr K
- c) W/m s K ✓
- d) Cal/cm s K

29. "Thermal conductivity represents the amount of heat conducted across the unit area when a temperature difference of one kelvin".

- a) True
- b) False ✓

30. Which of the following is the unit of thermal resistance?

- a) degree/kcal ✓
- b) hour degree
- c) s degree/kcal
- d) degree/W

31. Thermal conductivity is defined as the heat flow per unit time

- a) When the temperature gradient is unity
- b) Across the wall with no temperature
- c) Through a unit thickness of the wall
- d) Across unit area where the temperature gradient is unity ✓

32. Mark the matter with least value of thermal conductivity

- a) Air
- b) Water
- c) Ash
- d) Window glass ✓

33. Which one of the following forms of water have the highest value of thermal conductivity?

- a) Boiling water
- b) Steam
- c) Solid ice ✓
- d) Melting ice

34. The average thermal conductivities of water and air conform to the ratio

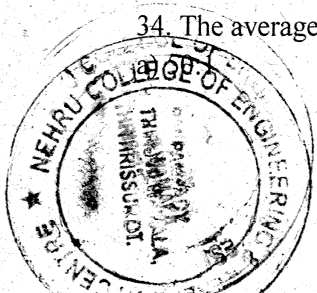

Principal  
Nehru College of  
Engineering and Research Centre  
Paripady Thiruvilwamala

- b) 25:1 ✓
- c) 5:1
- d) 15:1

35. Identify the very good insulator ✓

- a) Saw dust
- b) Cork
- c) Asbestos sheet
- d) Glass wool ✓

36. Most metals are good conductor of heat because of

- a) Transport of energy
- b) Free electrons and frequent collision of atoms ✓
- c) Lattice defects
- d) Capacity to absorb energy

37. Heat conduction in gases is due to

- a) Elastic impact of molecules
- b) Movement of electrons
- c) EM Waves
- d) Mixing of gases ✓

38. The heat energy propagation due to conduction heat transfer will be minimum for

- a) Lead
- b) Water
- c) Air ✓
- d) Copper

39. Cork is a good insulator because

- a) It is flexible
- b) It can be powdered
- c) Low density ✓
- d) It is porous ✓

40. Choose the false statement

- a) For pure metal thermal conductivity is more ✓
- b) Thermal conductivity decreases with increase in the density of the substance
- c) Thermal conductivity of dry material is lower than that of damp material
- d) Heat treatment causes variation in thermal conductivity

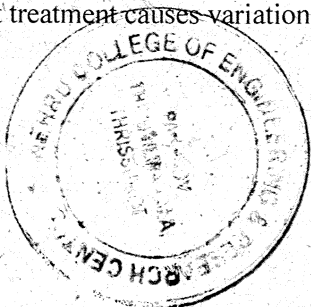

X      UH

PRINCIPAL  
Nehru College of  
Engineering and Research Centre  
Pampady Thiruvananthapuram, Thiruvananthapuram District  
Pin. 680 597 Kerala

41. From the concept of kinetic theory, mean travel velocity of the gas molecules is prescribed by the relation

- a)  $V = (3M/GT)^{1/2}$
- b)  $V = (3GT/M)^{1/2}$
- c)  $V = (6T/GM)^{1/2}$
- d)  $V = (3GT/2M)^{1/2}$

42. Low temperature insulation are used when the enclosure is at a temperature lower than the ambient temperature. Which one of the following is not a low temperature insulation?

- a) Asbestos
- b) Cork
- c) Cattle hair
- d) Slag wool

43. The value of Lorenz number in  $10^{-8} \text{ W ohms/K}^2$  is

- a) 2.02
- b) 2.35
- c) 2.56
- d) 2.45

44. For liquids, thermal conductivity is governed by the relation

- a)  $k = A c_p p^{7/3} / M^{1/3}$
- b)  $k = 2A c_p p^{4/3} / M^{2/3}$
- c)  $k = A c_p p^{4/3} / M^{1/3}$
- d)  $k = A c_p p^{8/3} / M^{1/3}$

45. Consider the following parameters

- (i) Composition
- (ii) Density
- (iii) Porosity
- (iv) Structure

Then, thermal conductivity of glass wool varies from sample to sample because of variation is

- a) i and ii
- b) i, ii, iii and iv
- c) i and iii
- d) i, ii and iii

46. The thermal conductivity and the electrical conductivity of a metal at absolute temperature are related as

- a)  $k/\sigma T$
- b)  $k/\sigma$



PRINCIPAL  
Nehru College of  
Engineering and Research Centre  
Panpady Thiruvananthapuram, Thiruvananthapuram  
Pin: 680 597 Kerala

- c)  $k \sigma / T$
- d)  $k/T$

47. The relation  $\nabla^2 t = 0$  is referred to as
- a) Poisson's equation
  - b) Fourier heat conduction equation
  - c) Solution for transient conduction
  - d) Laplace equation

48. The unit of thermal diffusivity is
- a)  $m^2/hr-K$
  - b)  $kcal/m^2-hr$
  - c)  $m^2/hr$
  - d)  $m/hr-K$

49. To effect a bond between two metal plates, 2.5 cm and 15 cm thick, heat is uniformly applied through the thinner plate by a radiant heat source. The bonding must be held at 320 K for a short time. When the heat source is adjusted to have a steady value of  $43.5 \text{ k W/m}^2$ , a thermocouple installed on the side of the thinner plate next to source indicates a temperature of 345 K. Calculate the temperature gradient for heat conduction through thinner plate. In the diagram, the upper plate is 2.5 cm thick while the lower is 15 cm thick.

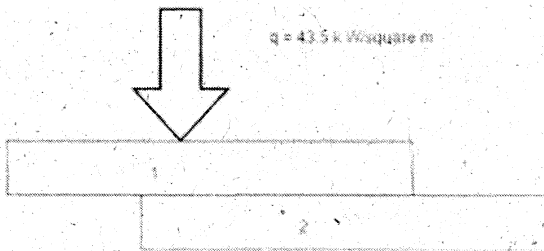

- a) - 1000 degree Celsius/m
- b) - 2000 degree Celsius/m
- c) - 3000 degree Celsius/m
- d) - 4000 degree Celsius/m

50. The diffusion equations  $\nabla^2 t + q_g = (1/\alpha) (dt/dr)$

Governs the temperature distribution under unsteady heat flow through a homogeneous and isotropic material. The Fourier equation follows from this expression when

- a) Temperature doesn't depends on time
- b) There is no internal heat generation
- c) Steady state conditions prevail
- d) There is no internal heat generation but unsteady state condition prevails

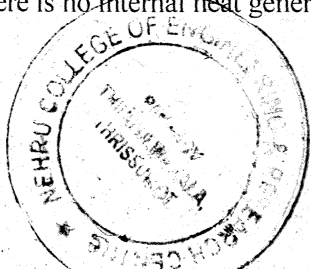

*Handwritten signature*  
**PRINCIPAL**  
 Nehru College of  
 Engineering and Research Centre  
 Pampady, Thrissur, Kerala  
 Pin - 686 007 Kerala



NEHRU COLLEGE OF ENGINEERING AND RESEARCH CENTRE  
(NAAC Accredited)  
(Approved by AICTE, Affiliated to APJ Abdul Kalam Technological University, Kerala)  
CERTIFICATION COURSE QUESTION PAPER



## HEAT AND MASS TRANSFER

1. The literature of heat transfer generally recognizes distinct modes of heat transfer. How many modes are there?

- a) One
- b) Two
- c) Three
- d) Four

X

2. Consider system A at uniform temperature  $t$  and system B at another uniform temperature  $T$  ( $t > T$ ). Let the two systems be brought into contact and be thermally insulated from their surroundings but not from each other. Energy will flow from system A to system B because of

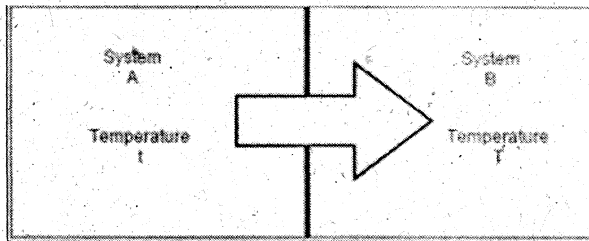

- a) Temperature difference
- b) Energy difference
- c) Mass difference
- d) Volumetric difference

3. An oil cooler in a high performance engine has an outside surface area  $0.12 \text{ m}^2$  and a surface temperature of  $65 \text{ degree Celsius}$ . At any intermediate time air moves over the surface of the cooler at a temperature of  $30 \text{ degree Celsius}$  and gives rise to a surface coefficient equal to  $45.4 \text{ W/m}^2 \text{ K}$ . Find out the heat transfer rate?

- a) 238.43 W
- b) 190.68 W
- c) 543.67 W
- d) 675.98 W

4. Unit of the rate of heat transfer is

- a) Joule
- b) Newton
- c) Pascal
- d) Watt

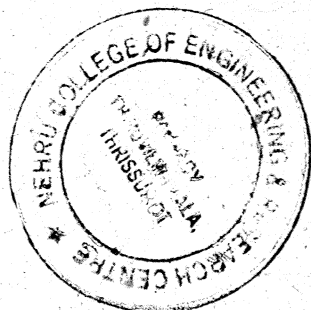

PRINCIPAL

Nehru College of  
Engineering and Research Centre  
Panpady Thiruvilwamala, Thiruvananthapuram  
Pin 680 597 Kerala

5. Convective heat transfer coefficient doesn't depend on

- a) Surface area ✓
- b) Space
- c) Time
- d) Orientation of solid surface

6. The rate equation used to describe the mechanism of convection is called Newton's law of cooling. So rate of heat flow by convection doesn't depend on

- a) Convective heat transfer coefficient ✓
- b) Surface area through which heat flows
- c) Time
- d) Temperature potential difference

7. How many types of convection process are there?

- a) One
- b) Three
- c) Four
- d) Two ✓

8. Thermal conductivity is maximum for which substance

- a) Silver
- b) Ice ✓
- c) Aluminum
- d) Diamond

9. A radiator in a domestic heating system operates at a surface temperature of 60 degree Celsius.

Calculate the heat flux at the surface of the radiator if it behaves as a black body

- a) 697.2 W/m<sup>2</sup> ✓
- b) 786.9 W/m<sup>2</sup>
- c) 324.7 W/m<sup>2</sup>
- d) 592.1 W/m<sup>2</sup>

View Answer

10. Which of the following is an example of forced convection?

- a) Chilling effect of cold wind on a warm body
- b) Flow of water in condenser tubes ✓
- c) Cooling of billets in the atmosphere
- d) Heat exchange on cold and warm pipes

11. Regarding one dimensional heat transfer, choose the correct statement

- a) Steady-  $f(x)$ , Unsteady-  $f(x, t)$  ✓
- b) Steady-  $f(x, t)$ , Unsteady-  $f(x)$
- c) Steady-  $f(x, y, t)$ , Unsteady-  $f(x)$

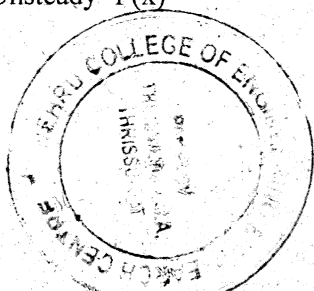

PRINCIPAL  
Nehru College of  
Engineering and Research Centre  
Thiruvilwamala, Thiruvananthapuram Dt.  
Pin - 680 597 Kerala

d) Steady-  $f(y, z)$ , Unsteady-  $f(y)$

12. Which statement is true regarding steady state condition?

- a) There is a variation in temperature in the course of time
- b) Heat exchange is constant
- c) It is a function of space and time coordinates
- d) Internal energy of the system changes

13. Which of the following is an example of steady state heat transfer?

- a) Boilers and turbines
- b) Cooling of I.C engine
- c) Chilling effect of cold wind on a warm body
- d) Electric bulb cools down by the surrounding atmosphere

14. Heat transfer in a long, hollow cylinder which is maintained at uniform but different temperatures on its inner and outer surfaces may be assumed to be taking place in which direction?

- a) Axial only
- b) Unpredictable
- c) Radial only
- d) No heat transfer takes place

15. Heat transfer takes place according to which law?

- a) Newton's law of cooling
- b) Second law of thermodynamics
- c) Newton's second law of motion
- d) First law of thermodynamics

16. Heat transfer takes place in liquids and gases is essentially due to

- a) Radiation
- b) Conduction
- c) Convection
- d) Conduction as well as convection

17. The appropriate rate equation for convective heat transfer between a surface and adjacent fluid is prescribed by

- a) Newton's first law
- b) Wein's displacement law

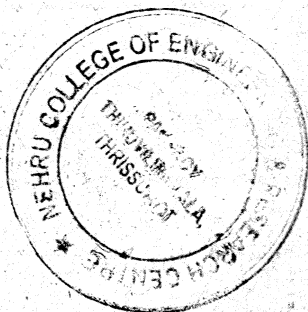

  
PRINCIPAL  
Nehru College of  
Engineering and Research Centre  
Panipady, Thiruvilwamala, Thiruvananthapuram Dt  
Pin : 680 597 Kerala

- c) Kirchhoff's law
- d) Newton's law of cooling

18. Identify the wrong statement

- a) The process of heat transfer is an irreversible process
- b) For heat exchange, a temperature gradient must exist
- c) A material medium is not necessary for heat transmission
- d) Heat flow doesn't depend on temperature

19. During a cold winter season, a person prefers to sit near a fire. Which of the following modes of heat transfer provides him the maximum heat?

- a) Conduction from the fire
- b) If it is near the fire, convection sounds good
- c) Convection and radiation together
- d) Radiation will provide quick warmth

20. Most unsteady heat flow occurs

- a) Through the walls of the refrigerator
- b) During annealing of castings
- c) Through the walls of the furnace
- d) Through lagged pipe carrying steam

21. The famous Fourier series is named after

- a) Diller and Ryan
- b) J.B. Joseph Fourier
- c) Stefan- Boltzmann
- d) Wein's

22. Fourier law of heat conduction is best represented by

- a)  $Q = -k A d t / d x$
- b)  $Q = k A d x / d t$
- c)  $Q = -k A$
- d)  $Q = k d t / d x$

23. Here are some assumptions that are made for Fourier law. Identify the wrong one

- a) No internal heat generation
- b) Steady state heat conduction
- c) Non- linear temperature profile
- d) Isotropic and homogenous material

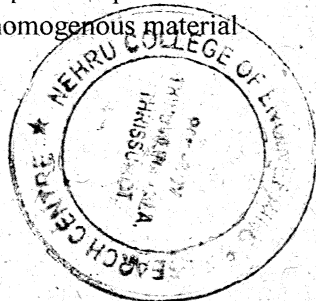

  
PRINCIPAL  
Nehru College of  
Engineering and Research Cent  
Panpady Thiruvilwamala Thiruvananthapuram  
Pin 650 507 Kerala

24. Consider the following statements:

The Fourier heat conduction equation

$$Q = -k A \frac{dt}{dx}$$

Presumes

- i) Steady state conditions
- ii) Constant value of thermal conductivity
- iii) Uniform temperature at the wall surface
- iv) One dimensional heat flow

Which of these statements are correct?

- a) i, ii and iii
- b) i, ii and iv
- c) i, iii and iv
- d) i, iii and iv

25. The diagram shows heat conduction through a plane wall. The surface temperature is 475 K and it radiates heat to the surroundings at 335 K. If thermal conductivity of the material is 12.5 W/m degree, find the temperature gradient. Let convective coefficient be 80 W/m<sup>2</sup> degree and radiation factor is 0.9

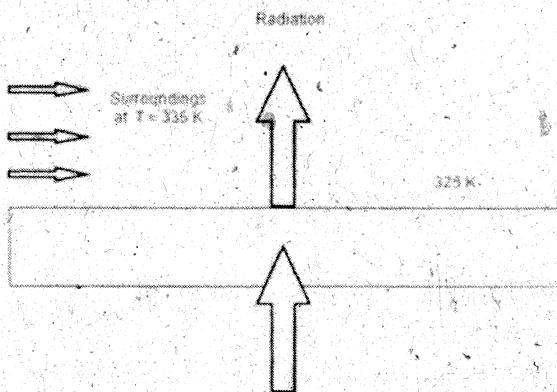

- a) - 1052.4 degree celsius
- b) - 2052.4 degree celsius
- c) - 3052.4 degree celsius
- d) - 4052.4 degree celsius

26. Negative sign in Fourier heat conduction equation indicates

- a) Heat always flow is in the direction of positive temperature gradient
- b) Heat always flow in the direction of negative temperature gradient
- c) No heat flow is there
- d) Data is insufficient

27. Transmission of heat i.e. molecular is smallest in case of

- a) Gases
- b) Liquids
- c) Alloys

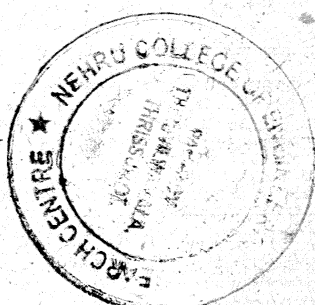

PRINCIPAL

Nehru College of  
Engineering and Research Centre  
Pampady Thiruvilwamala, Thiruvananthapuram

d) Solids

28. Which one is not the unit of thermal conductivity?

- a) kcal/m hr K
- b) ~~KJ/m hr K~~
- c) ~~W/m s K~~
- d) Cal/cm s K

29. "Thermal conductivity represents the amount of heat conducted across the unit area when a temperature difference of one kelvin".

- a) True
- b) ~~False~~

30. Which of the following is the unit of thermal resistance?

- a) degree/kcal
- b) hour degree
- c) s degree/kcal
- d) ~~degree/W~~

31. Thermal conductivity is defined as the heat flow per unit time

- a) ~~When the temperature gradient is unity~~
- b) ~~Across the wall with no temperature~~
- c) ~~Through a unit thickness of the wall~~
- d) ~~Across unit area where the temperature gradient is unity~~

32. Mark the matter with least value of thermal conductivity

- a) ~~Air~~
- b) Water
- c) Ash
- d) Window glass

33. Which one of the following forms of water have the highest value of thermal conductivity?

- a) Boiling water
- b) Steam
- c) ~~Solid ice~~
- d) Melting ice

34. The average thermal conductivities of water and air conform to the ratio

- a) 50:1

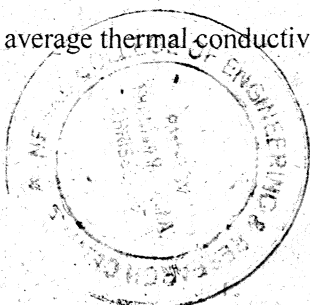

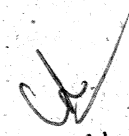
  
**PRINCIPAL**  
Nehru College of  
Engineering and Research Centre  
Pampady Thiruvilwamala, Thassur Dt  
Pin - 680 597 Kerala

- b) 25:1
- c) 5:1
- d) 15:1

35. Identify the very good insulator

- a) Saw dust
- b) Cork
- c) Asbestos sheet
- d) Glass wool

36. Most metals are good conductor of heat because of

- a) Transport of energy
- b) Free electrons and frequent collision of atoms
- c) Lattice defects
- d) Capacity to absorb energy

37. Heat conduction in gases is due to

- a) Elastic impact of molecules
- b) Movement of electrons
- c) EM Waves
- d) Mixing of gases

38. The heat energy propagation due to conduction heat transfer will be minimum for

- a) Lead
- b) Water
- c) Air
- d) Copper

39. Cork is a good insulator because

- a) It is flexible
- b) It can be powdered
- c) Low density
- d) It is porous

40. Choose the false statement

- a) For pure metal thermal conductivity is more
- b) Thermal conductivity decreases with increase in the density of the substance
- c) Thermal conductivity of dry material is lower than that of damp material
- d) Heat treatment causes variation in thermal conductivity

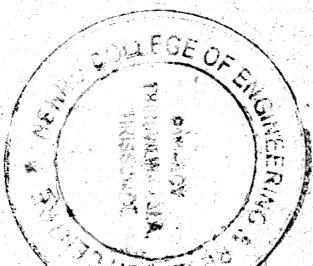

*ch*  
PRINCIPAL  
Nehru College of  
Engineering and Research Centre  
Pamapady, Thiruvilwamala, Thirissur Dt  
Pin. 686 697 Kerala

41. From the concept of kinetic theory, mean travel velocity of the gas molecules is prescribed by the relation

- a)  $V = (3M/GT)^{1/2}$
- ~~b)  $V = (3GT/M)^{1/2}$~~
- c)  $V = (6T/GM)^{1/2}$
- d)  $V = (3GT/2M)^{1/2}$

42. Low temperature insulation are used when the enclosure is at a temperature lower than the ambient temperature. Which one of the following is not a low temperature insulation?

- ~~a) Asbestos~~
- b) Cork
- c) Cattle hair
- d) Slag wool

43. The value of Lorenz number in  $10^{-8}$  W ohms/K<sup>2</sup> is

- a) 2.02
- b) 2.35
- c) 2.56
- ~~d) 2.45~~

44. For liquids, thermal conductivity is governed by the relation

- a)  $k = A c_p \rho^{7/3} / M^{1/3}$
- b)  $k = 2A c_p \rho^{4/3} / M^{2/3}$
- ~~c)  $k = A c_p \rho^{4/3} / M^{1/3}$~~
- d)  $k = A c_p \rho^{8/3} / M^{1/3}$

45. Consider the following parameters

- (i) Composition
- ~~(ii) Density~~
- (iii) Porosity
- (iv) Structure

Then, thermal conductivity of glass wool varies from sample to sample because of variation is

- a) i and ii
- ~~b) i, ii, iii and iv~~
- c) i and iii
- d) i, ii and iii

46. The thermal conductivity and the electrical conductivity of a metal at absolute temperature are related as

- ~~a)  $k/\sigma T$~~
- b)  $k/\sigma$

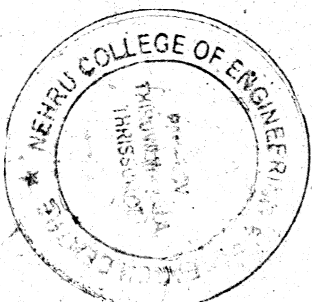

  
PRINCIPAL  
Nehru College of  
Engineering and Research Centre  
Panipady Thiruvilwamala, Thiruvananthapuram Dt  
Pin - 680 597 Kerala

- c)  $k \sigma/T$
- d)  $k/T$

47. The relation  $\nabla^2 t = 0$  is referred to as

- a) Poisson's equation
- b) Fourier heat conduction equation
- c) Solution for transient conduction
- d) Laplace equation

48. The unit of thermal diffusivity is

- a)  $m^2/hr-K$
- b)  $kcal/m^2-hr$
- c)  $m^2/hr$
- d)  $m/hr-K$

49. To effect a bond between two metal plates, 2.5 cm and 15 cm thick, heat is uniformly applied through the thinner plate by a radiant heat source. The bonding must be held at 320 K for a short time. When the heat source is adjusted to have a steady value of  $43.5 \text{ k W/m}^2$ , a thermocouple installed on the side of the thinner plate next to source indicates a temperature of 345 K. Calculate the temperature gradient for heat conduction through thinner plate. In the diagram, the upper plate is 2.5 cm thick while the lower is 15 cm thick.

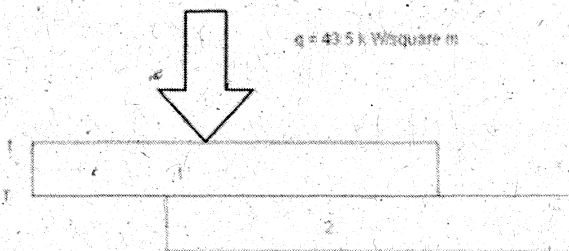

- a) -1000 degree Celsius/m
- b) -2000 degree Celsius/m
- c) -3000 degree Celsius/m
- d) -4000 degree Celsius/m

50. The diffusion equations

$$\nabla^2 t + q_g = (1/\alpha) (d t / d r)$$

Governs the temperature distribution under unsteady heat flow through a homogeneous and isotropic material. The Fourier equation follows from this expression when

- a) Temperature doesn't depend on time
- b) There is no internal heat generation
- c) Steady state conditions prevail
- d) There is no internal heat generation but unsteady state condition prevails



PRINCIPAL  
Nehru College of  
Engineering and Research Centre  
Pannapady, Tripunithur, Thiruvananthapuram  
Dist. Ernakulam, Kerala



**NEHRU COLLEGE OF ENGINEERING AND RESEARCH CENTRE**  
**(NAAC Accredited)**  
(Approved by AICTE, Affiliated to APJAKTU & Calicut University, Kerala)  
ACADAMIC YEAR (2015-16)



**DEPARTMENT OF MECHATRONICS ENGINEERING**  
**OFFERING CERTIFIED COURSE ON**  
**HEAT AND MASS TRANSFER**

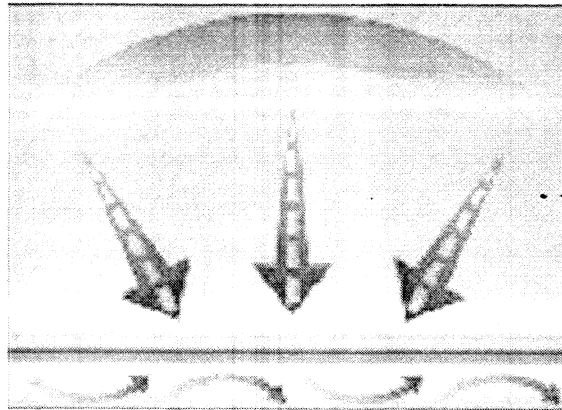

**COURSE POINTS**

- ✓ CONDUCTION
- ✓ CONVECTION
- ✓ PHASE CHANGE HEAT TRANSFER AND HEAT EXCHANGERS
- ✓ RADIATION & MASS TRANSFER

**FACULTY**

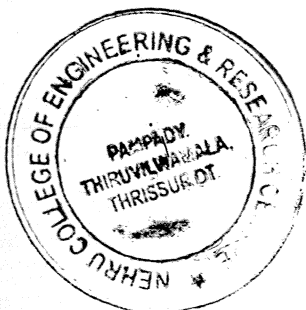

**PRINCIPAL**  
Nehru College of  
Engineering and Research Centre  
Pampady Thiruvilwamala, Thrissur  
Pin 680 597 Kerala



# Certificate OF COMPLETION

.....ANEESH K A (NCANEMTOLO).....had successfully completed  
the certified course "HEAT AND MASS TRANSFER" during 2015-16 conducted by the  
Department of Mechatronics Engineering, Nehru College of Engineering and  
Research Centre, Pampady, Thrissur.

PROGRAM CO-ORDINATOR

HEAD OF DEPARTMENT

PRINCIPAL  
Nehru College of  
Engineering and Research Centre  
Pampady, Thiruvilwamala, Thrissur District  
Pin 680 597 Kerala

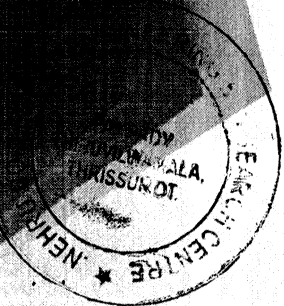



# Certificate OF COMPLETION

.....ALEN BABY (NCAOEMTOII).....had successfully completed  
the certified course "HEAT AND MASS TRANSFER" during 2015-16 conducted by the  
Department of Mechatronics Engineering, Nehru College of Engineering and  
Research Centre, Pampady, Thrissur.

PROGRAM CO-ORDINATOR

HEAD OF DEPARTMENT

PRINCIPAL

Nehru College of  
Engineering and Research Centre  
Pampady, Thiruvilwamala, Thrissur Dt.  
Pin 680 597 Kerala

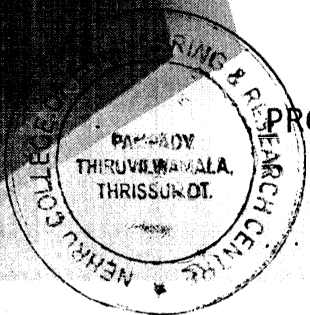

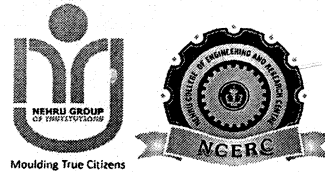

# Certificate OF COMPLETION

.....KIRAN GEORGE (NCE15MC034).....had successfully completed  
the certified course "HEAT AND MASS TRANSFER" during 2015-16 conducted by the  
Department of Mechatronics Engineering, Nehru College of Engineering and  
Research Centre, Pampady, Thrissur.

PROGRAM CO-ORDINATOR

HEAD OF DEPARTMENT

PRINCIPAL

Nehru College of  
Engineering and Research Centre  
Pampady, Thiruvilwamala, Thrissur District  
Pin - 680 597 Kerala

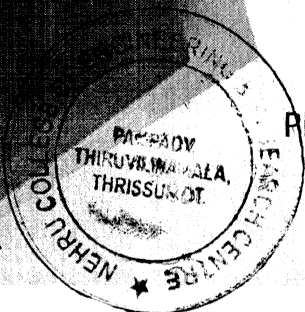



# Certificate OF COMPLETION

.....RESHMA S (NCE15MC046).....had successfully completed  
the certified course "HEAT AND MASS TRANSFER" during 2015-16 conducted by the  
Department of Mechatronics Engineering, Nehru College of Engineering and  
Research Centre, Pampady, Thrissur.

PROGRAM CO-ORDINATOR

HEAD OF DEPARTMENT

PRINCIPAL  
Nehru College of  
Engineering and Research Centre  
Pampady, Thiruvilwamala, Thrissur Dt.  
Pin 680 597 Kerala

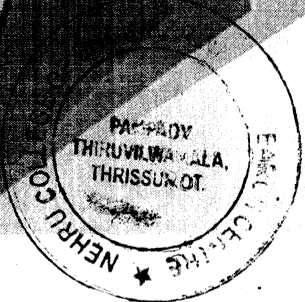

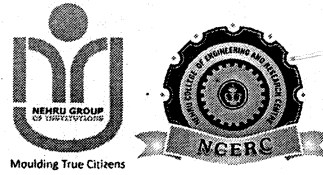

# Certificate OF COMPLETION

.....SAFVAN (NCAOEMT048).....had successfully completed  
the certified course "HEAT AND MASS TRANSFER" during 2015-16 conducted by the  
Department of Mechatronics Engineering, Nehru College of Engineering and  
Research Centre, Pampady, Thrissur.

PROGRAM CO-ORDINATOR

HEAD OF DEPARTMENT

PRINCIPAL  
Nehru College of  
Engineering and Research Centre  
Pampady, Thiruvilwamala, Thrissur  
Pin - 680 597 Kerala

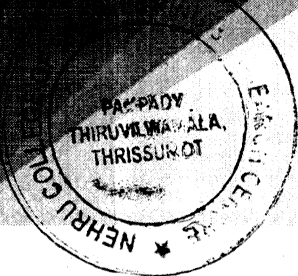



**NEHRU COLLEGE OF ENGINEERING AND RESEARCH CENTRE**  
(NAAC Accredited)  
(Approved by AICTE, Affiliated to University of Calicut & APJ Abdul Kalam Technological University, Kerala)



**ADMISSION TO CERTIFICATION COURSE (2015-2016)**

Applications are invited for admission for the Certification Course 'WIRELESS SENSOR NETWORKS' offered by the Department of Mechatronics Engineering, Nehru college of Engineering and Research Centre, Pampady, Thrissur.

**Eligibility criteria**

All UG engineering students of MTR Department are eligible

**Timing:**

1 hour per day from 4.00pm to 5.00pm for 30 hours of the course. Saturday and Sunday may be used at the discretion of the department.

**Attendance**

A minimum of 75% attendance is required for writing the examination.

**Important Dates**

Commencement of classes: 05-01-2016

Examination Date: 31-03-2016



HOD

PRINCIPAL  
Nehru College of  
Engineering and Research Centre  
Pampady Thiruvilwamala, Thrissur Dt  
Pin 680 597 Kerala

FROM

MR. MANU R KRISHNAN

ASSISTANT PROFESSOR

MTR DEPARTMENT, NCERC PAMPADY

TO

HEAD OF THE DEPARTMENT

MTR DEPARTMENT

NCERC PAMPADY

SUBJECT: Requisition for conducting Certification Course on "WIRELESS SENSOR NETWORKS"

Respected Sir,

As the Assistant Professor of Mechatronics Engineering, I would like to request your support and permission to conduct a Certification Course on "WIRELESS SENSOR NETWORKS" from 05-01-2016. It will be a 30 hour course scheduled for July to October of this academic year 2015-2016. It is therefore important for students to have a deep understanding of upcoming methodologies to enhance knowledge dissemination to students for doing projects.

All UG Engineering students of MTR Department are eligible for this course.

Sincerely,



PLACE: PAMPADY

DATE: 11/2/15

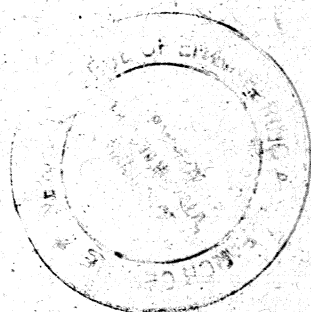

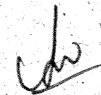
  
PRINCIPAL

Nehru College of  
Engineering and Research Centre  
Pampady Thiruvilwamala, Thrissur Dt  
Pin - 680 597, Kerala

**NEHRU COLLEGE OF ENGINEERING AND RESEARCH CENTRE**  
**(ACCREDITED BY NAAC)**  
**PAMPADY, THIRUVILWAMALA, THRISSUR DIST.**

MINUTES OF DEPARTMENT ADVISORY COMMITTEE MEETING HELD ON 11/07/2015

A meeting of the Department Advisory Committee (DAC) was held on 11<sup>th</sup> July 2015 at 1:00 PM in the chamber of HoD, MTR department.

The following members were present:

1. Prof. Radhakrishnan-HoD, MTR Dept.
2. Mr. Niveth L-Assistant Professor, MTR Dept.
3. Mr. Midhunraj P K-Assistant Professor, MTR Dept.
4. Mr. Ranjith P N-Assistant Professor, MTR Dept.
5. Mr. Manu R Krishnan-Assistant Professor, MTR Dept.

The following decisions were taken:

6. It was decided to conduct a certificate course on "WIRELESS SENSOR NETWORKS" during the second and fourth Saturdays of the academic year 2015-16 for a period of 30 hours.
7. The course will update the technical knowledge of students in the latest developments related to the field of wireless sensor networks.
8. It was decided to provide the course for the UG students of Mechatronics Engg. Department.
9. Also, it was decided to ensure compulsory attendance and staff advisors should monitor the same.

The meeting came to an end at 1:45 PM.



  
HoD



**PRINCIPAL**  
Nehru College of  
Engineering and Research Centre  
Pampady, Thiruvilwamala, Thrissur Dt.  
Pin: 686 561, Kerala

FROM

MR. MANU R KRISHNAN

ASSISTANT PROFESSOR

MTR DEPARTMENT, NCERC PAMPADY

*Forwarded to Principal*  

TO

THE PRINCIPAL,

NCERC PAMPADY

Through HOD

Respected Sir,

SUBJECT: Requisition for conducting Certification Course on "WIRELESS SENSOR NETWORKS" Reg.

Students need a deep understanding of upcoming methodologies to enhance knowledge dissemination for doing projects. Wireless Sensor Networks measure environmental conditions like temperature, sound, pollution levels, humidity, wind, and so on, so Mechatronics Engineering department would like to conduct a Certification Course on "WIRELESS SENSOR NETWORKS" from 05-01-2016. It will be a 30 hour course scheduled for July to October of this academic year 2015-2016. Kindly request you to give the permission for the same.

All UG Engineering students of MTR Department are eligible for this course.

Sincerely,



PLACE: PAMPADY

DATE: 4/12/15



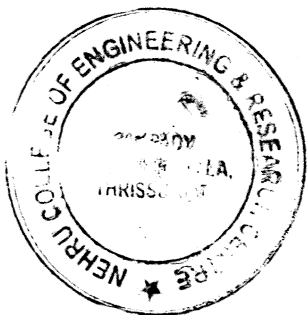

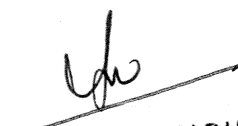
  
PRINCIPAL  
Nehru College of  
Engineering and Research Centre  
Pampady Thiruvilwamala, Thiruvananthapuram



**NEHRU COLLEGE OF ENGINEERING AND RESEARCH CENTRE**  
**(NAAC Accredited)**

(Approved by AICTE, Affiliated to APJ Abdul Kalam Technological University, Kerala)  
**ADD ON COURSE SYLLABUS AND SCHEDULE**



## **WIRELESS SENSOR NETWORKS**

### **UNIT I AD HOC NETWORKS – INTRODUCTION AND ROUTING PROTOCOLS**

Elements of Ad hoc Wireless Networks, Issues in Ad hoc wireless networks, Example commercial applications of Ad hoc networking, Ad hoc wireless Internet, Classifications of Routing Protocols, Table Driven Routing Protocols – Destination Sequenced Distance Vector (DSDV), On-Demand Routing protocols – Ad hoc On-Demand Distance Vector Routing (AODV).

### **UNIT II SENSOR NETWORKS – INTRODUCTION & ARCHITECTURES**

Challenges for Wireless Sensor Networks, Enabling Technologies for Wireless Sensor Networks, WSN application examples, Single-Node Architecture – Hardware Components, Energy Consumption of Sensor Nodes, Network Architecture – Sensor Network Scenarios, Transceiver Design Considerations, Optimization Goals and Figures of Merit.

### **UNIT III SENSOR NETWORK SECURITY**

Network Security Requirements, Issues and Challenges in Security Provisioning, Network Security Attacks, Layer wise attacks in wireless sensor networks, possible solutions for jamming, tampering, black hole attack, flooding attack. Key Distribution and Management, Secure Routing – SPINS, reliability requirements in sensor networks.

### **UNIT IV SENSOR NETWORK PLATFORMS AND TOOLS**

Sensor Node Hardware – Berkeley Motes, Programming Challenges, Node-level software platforms – TinyOS, nesC, CONTIKIOS, Node-level Simulators – NS2 and its extension to sensor networks, COOJA, TOSSIM, Programming beyond individual nodes – State centric programming. MAC Protocols for Wireless Sensor Networks, Low Duty Cycle Protocols And Wakeup Concepts – S-MAC

### **COURSE SCHEDULE**

Commencement of classes: 05-01-2016

Examination Date: 31-03-2016

  
**PROGRAM COORDINATOR**

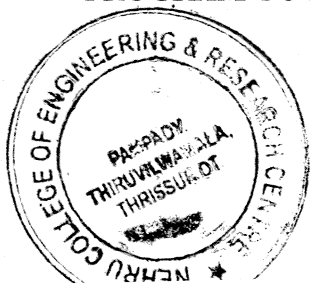

  
**HOD**

  
**PRINCIPAL**

Nehru College of  
Engineering and Research Centre  
Pampady, Thiruvilwamala, Thirissur Dist  
Pin 680 597 Kerala

**NEHRU COLLEGE OF ENGINEERING & RESEARCH CENTRE**

Pampady, Thiruvilwamala, Thrissur Dt.

**DEPARTMENT OF MECHATRONICS ENGINEERING**

**WIRELESS SENSOR NETWORK**

Attendance Sheet

SL. NO.	REG. NO.	NAME OF STUDENT	5/1/16	6/1/16	7/1/16	8/1/16	9/1/16	11/1/16	12/1/16	13/1/16	14/1/16	15/1/16
1	NCANEMT001	ABHIJITH C	A	/	/	/	/	/	/	/	A	/
2	NCANEMT003	AKARSH S	/	/	/	A	/	/	/	/	/	A
3	NCANEMT006	ALOSHIOUS M DASAN	/	/	/	/	/	A	/	/	/	/
4	NCANEMT008	ANARGH VISWANATH	/	/	/	/	/	/	/	A	/	/
5	NCANEMT012	ARJUNGOPI	/	/	A	/	/	/	/	/	/	/
6	NCANEMT015	ARJUN VYSAKH C	/	/	/	A	/	A	/	/	/	A
7	NCANEMT016	ARJUN VIJAY	A	A	/	/	/	/	A	A	/	/
8	NCANEMT019	ATHUL AJITH K	/	/	A	A	A	/	/	/	/	/
9	NCANEMT022	CIBIN JOHN JOSEPH	/	/	/	/	/	A	/	/	/	/
10	NCANEMT025	EMIL TOM	A	/	/	/	/	/	/	/	A	/
11	NCANEMT028	IRSHAD MOHAMED GHANI	/	/	/	/	/	/	/	/	/	A
12	NCANEMT032	JYOTHISH M N	/	/	/	/	/	A	/	/	/	/
13	NCANEMT034	MOHAMMED MISHAL K	/	/	A	/	/	/	A	/	/	/
14	NCANEMT036	MUHAMMED ZULFAN P B	A	A	A	A	/	/	/	A	/	A
15	NCANEMT040	RAMKUMAR	/	/	/	/	/	/	A	/	/	/
16	NCANEMT045	SHAHSAD M	/	/	/	/	/	A	/	/	/	/
17	NCANEMT047	SIDDARTH A T	/	/	/	/	/	/	/	/	/	A
18	NCANEMT050	VISHNUDAS M	/	/	/	/	/	/	A	/	/	/
19	NCANEMT054	VARSHA C K	/	/	/	/	A	/	/	/	/	/
20	NCAOEMT001	AAZTLEKHAN N	/	/	/	/	/	/	/	A	/	/
21	NCAOEMT004	ABY POIUSON	/	/	/	/	/	/	/	/	/	A
22	NCAOEMT007	AJAY AUGUSTINE	/	/	/	A	/	/	/	/	/	/
23	NCAOEMT010	AKSHAY R	/	A	/	/	/	/	/	/	/	/
24	NCAOEMT012	ALISHIHAN M S	/	/	/	A	/	/	/	/	/	/
25	NCAOEMT013	ANAND A S	/	/	/	/	/	/	/	/	/	/
26	NCAOEMT014	ANANDHU K V	/	/	/	/	/	/	/	A	/	/



**PRINCIPAL**  
 Nehru College of  
 Engineering and Research Centre  
 Pampady, Thiruvilwamala, Thrissur Dt  
 Kerala 689 597

27	NCAOEMT021	ATHUL AJITH	/	/	/	/	/	A	/	/	/	A
28	NCAOEMT026	FEMINA SHIREEN A	/	/	/	/	/	/	/	/	A	/
29	NCAOEMT031	HARIKRISHNAN N	/	/	/	/	/	/	/	A	/	/
30	NCAOEMT034	JERIN JOHN	A	/	/	/	/	/	/	/	/	/
31	NCAOEMT038	JINU P M	/	/	A	/	/	/	/	/	/	/
32	NCAOEMT042	MOHAMMED NIBRAS YOOSUF K	/	/	/	/	A	/	/	/	/	/
33	NCAOEMT043	MOYALAN JINTO JOSAN	/	A	/	/	/	/	/	/	/	A
34	NCAOEMT046	RASHAF ALI K	/	/	/	/	/	/	/	/	A	/
35	NCAOEMT049	SAJITH V	/	/	/	/	/	A	/	/	/	/
36	NCAOEMT054	SHINILNATH	/	/	/	/	/	/	A	/	/	/
37	NCAOEMT055	SIDHARTH N PISHARODY	/	/	/	/	/	/	A	/	/	/
38	NCAOEMT056	SRIRAG	/	A	/	/	/	/	/	/	/	/
39	NCAOEMT058	VISHNU K ANAND	/	/	A	/	/	/	/	/	/	/
40	NCAOEMT061	NOBLE VARGHESE	/	/	/	A	/	/	/	/	/	/
41	NCE15MC004	ADITHYA MOHAN	A	/	/	/	/	/	/	/	A	/
42	NCE15MC005	AJAY ANAND C	/	/	/	/	/	A	/	/	/	/
43	NCE15MC006	AKASH A	/	/	/	/	A	/	/	/	/	A
44	NCE15MC009	ALBIN LEO	/	/	/	/	/	A	/	/	/	/
45	NCE15MC010	ALIND ROY	/	/	/	/	/	/	/	/	/	A
46	NCE15MC017	ATHUL VAISHNAV C	/	/	/	/	/	/	/	A	/	/
47	NCE15MC019	DARIL SILVA	/	A	/	/	/	/	/	/	/	/
48	NCE15MC026	JEROM MATHEW PAUL	A	/	/	/	/	/	/	/	/	/
49	NCE15MC027	JITHIN T J	/	/	/	A	/	/	/	/	/	/
50	NCE15MC035	MARSHEL MARTIN	/	/	/	/	/	/	A	/	/	/
51	NCE15MC036	MOHAMMED HANI SHERIF	/	/	/	/	/	A	/	/	/	/

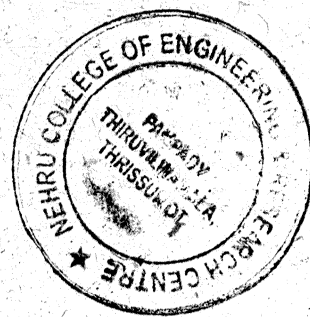

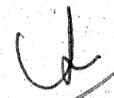
  
**PRINCIPAL**  
 Nehru College of  
 Engineering and Research Centre  
 Pampady Thiruvilwamala, Thiruvananthapuram Dt  
 Pin 680 597 Kerala

52	NCE15MC037	MOHAMED JUNAID M C	/	/	A	/	/	/	/	A	/	/	/
53	NCE15MC043	NIRMAL C RAVINDRAN	/	/	/	A	/	/	/	/	/	/	/
54	NCE15MC044	RAHUL A M	/	/	/	/	A	/	/	A	/	/	/
55	NCE15MC050	SAGAR JOHNY C	/	A	/	/	/	/	/	/	/	/	/
56	NCE15MC051	SARAS MOHAN	/	/	/	/	/	A	/	/	/	/	/
57	NCE15MC055	SREERAG K R	/	/	A	A	/	/	/	/	/	/	/
58	NCE15MC056	SUDHARSHAN K	/	/	/	/	A	A	/	/	/	/	/
59	NCE15MC058	VISHNU P V	/	A	/	/	/	/	A	/	/	/	/
60	NCE15MC060	VISHNU RAJ P	A	/	/	/	/	/	/	/	/	/	/



PROGRAM COORDINATOR

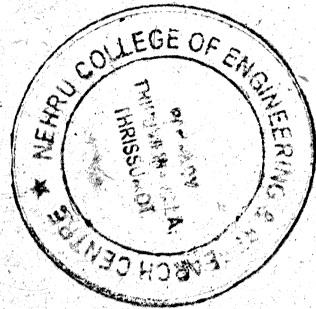
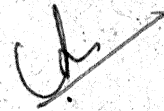

HOD

PRINCIPAL  
Nehru College of  
Engineering and Research Centre  
Pampady Thiruvilwamala Thirissur Dt  
Pin 680 597 Kerala

**NEHRU COLLEGE OF ENGINEERING & RESEARCH CENTRE**

Pampady, Thiruvilwamala, Thrissur Dt.

**DEPARTMENT OF MECHATRONICS ENGINEERING**

**WIRELESS SENSOR NETWORK**

Attendance Sheet

SL. NO.	REG. NO.	NAME OF STUDENT	16/1/16	18/1/16	19/1/16	20/1/16	21/1/16	22/1/16	23/1/16	25/1/16	27/1/16	28/1/16
1	NCANEMT001	ABHIJITH C	/	A	/	/	/	/	/	/	/	/
2	NCANEMT003	AKARSH S	/	/	/	/	/	/	/	/	A	/
3	NCANEMT006	ALOSHIOUS M DASAN	/	/	/	/	/	/	/	/	A	/
4	NCANEMT008	ANARGH VISWANATH	/	/	/	/	/	/	/	/	A	/
5	NCANEMT012	ARJUNGOPI	/	/	A	/	/	/	/	/	/	/
6	NCANEMT015	ARJUN VYSAKH C	/	/	/	A	A	/	/	/	/	/
7	NCANEMT016	ARJUN VIJAY	/	/	A	/	/	A	/	/	/	/
8	NCANEMT019	ATHUL AJITH K	A	/	/	/	/	/	/	/	/	/
9	NCANEMT022	CIBIN JOHN JOSEPH	/	/	/	A	/	/	/	/	/	/
10	NCANEMT025	EMIL TOM	/	/	/	/	/	/	A	A	/	/
11	NCANEMT028	IRSHAD MOHAMED GHANI	/	/	/	/	/	/	/	/	/	A
12	NCANEMT032	JYOTHISH M N	/	/	/	/	/	A	/	/	/	/
13	NCANEMT034	MOHAMMED MISHAL K	/	/	/	A	/	/	/	/	/	/
14	NCANEMT036	MUHAMMED ZULFAN P B	A	/	/	/	A	A	A	A	/	/
15	NCANEMT040	RAMKUMAR	/	A	A	/	/	/	/	/	/	/
16	NCANEMT045	SHAH SAD M	/	/	/	A	/	/	/	A	/	/
17	NCANEMT047	SIDDARTH A T	/	/	/	/	/	/	/	/	A	/
18	NCANEMT050	VISHNU DAS M	/	/	/	/	/	A	/	/	/	/
19	NCANEMT054	VARSHA C K	/	/	/	/	/	/	/	A	/	/
20	NCAOEMT001	AAZTLEKHAN N	/	/	/	/	/	A	/	/	/	/
21	NCAOEMT004	ABY POIUSON	/	A	A	/	/	/	/	/	/	/
22	NCAOEMT007	AJAY AUGUSTINE	/	/	/	/	/	/	/	/	A	A
23	NCAOEMT010	AKSHAY R	/	A	/	/	/	/	A	/	/	/
24	NCAOEMT012	ALISHIHAN M S	A	/	/	/	/	/	A	/	/	/
25	NCAOEMT013	ANAND A S	/	/	A	A	A	/	/	/	/	/
26	NCAOEMT014	ANANDHU K V	/	/	/	/	/	/	A	/	/	/

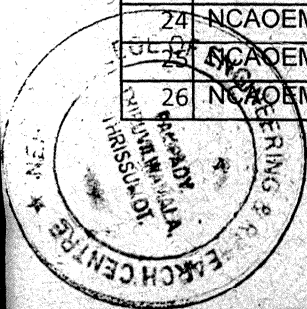

**PRINCIPAL**

Nehru College of  
Engineering and Research Centre  
Pampady, Thiruvilwamala, Thrissur Dt.  
Pin - 680 507, Kerala

27	NCAOEMT021	ATHUL AJITH	/	/	A	/	/	/	/	/	A
28	NCAOEMT026	FEMINA SHIREEN A	/	/	/	/	A	/	/	/	/
29	NCAOEMT031	HARIKRISHNAN N	/	/	A	A	/	/	/	/	/
30	NCAOEMT034	JERIN JOHN	/	A	/	/	/	/	/	/	/
31	NCAOEMT038	JINU P M	/	/	/	/	A	/	/	A	/
32	NCAOEMT042	MOHAMMED NIBRAS YOOSUF K	A	A	/	/	/	/	/	A	/
33	NCAOEMT043	MOYALAN JINTO JOSAN	/	/	/	/	/	A	/	/	/
34	NCAOEMT046	RASHAF ALI K	/	/	/	/	/	/	A	A	/
35	NCAOEMT049	SAJITH V	/	A	/	/	/	/	/	/	A
36	NCAOEMT054	SHINILNATH	/	/	/	/	A	/	/	/	/
37	NCAOEMT055	SIDHARTH N PISHARODY	/	/	/	/	/	/	/	A	/
38	NCAOEMT056	SRIRAG	/	/	A	A	A	/	/	/	/
39	NCAOEMT058	VISHNU K ANAND	/	/	/	/	/	A	/	A	/
40	NCAOEMT061	NOBLE VARGHESE	/	/	/	/	A	/	/	/	A
41	NCE15MC004	ADITHYA MOHAN	/	/	/	/	/	A	/	A	/
42	NCE15MC005	AJAY ANAND C	A	A	/	/	/	/	/	/	/
43	NCE15MC006	AKASH A	/	/	/	/	/	/	/	/	A
44	NCE15MC009	ALBIN LEO	/	/	/	/	A	A	A	/	A
45	NCE15MC010	ALIND ROY	/	/	/	/	/	/	/	/	A
46	NCE15MC017	ATHUL VAISHNAV C	/	/	/	/	/	/	/	/	A
47	NCE15MC019	DARIL SILVA	A	/	/	/	/	/	/	/	/
48	NCE15MC026	JEROM MATHEW PAUL	/	/	/	A	/	/	/	/	/
49	NCE15MC027	JITHIN T J	/	/	/	/	/	/	A	A	/
50	NCE15MC035	MARSHEL MARTIN	/	A	/	/	/	/	/	/	/
51	NCE15MC036	MOHAMMED HANI SHERIF	/	/	A	/	/	/	/	A	/

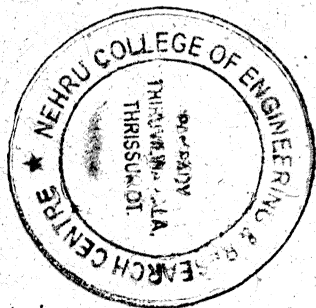

  
**PRINCIPAL**  
 Nehru College of  
 Engineering and Research Centre  
 Pampady Thiruvilwamala, Thiruvananthapuram  
 Pin - 680 597 Kerala

52	NCE15MC037	MOHAMED JUNAID M C	/	A	/	/	A	/	A	/	/	/
53	NCE15MC043	NIRMAL C RAVINDRAN	/	/	/	/	A	/	/	A	/	/
54	NCE15MC044	RAHUL A M	/	/	A	/	/	/	/	/	/	A
55	NCE15MC050	SAGAR JOHNY C.	/	/	/	A	/	/	/	/	/	/
56	NCE15MC051	SARAS MOHAN	A	/	/	/	/	A	/	/	/	/
57	NCE15MC055	SREERAG K R	/	/	/	/	/	/	A	/	A	/
58	NCE15MC056	SUDHARSHAN K	/	/	/	/	/	/	/	/	A	A
59	NCE15MC058	VISHNU P V	A	A	/	/	/	/	/	/	/	/
60	NCE15MC060	VISHNU RAJ P	/	/	/	A	/	/	/	/	/	/



PROGRAM COORDINATOR



HOD

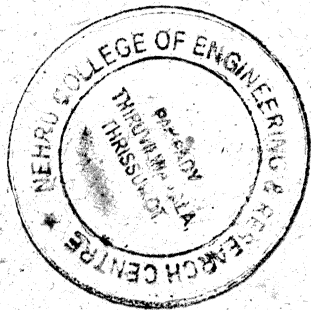

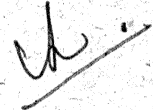
  
**PRINCIPAL**  
 Nehru College of  
 Engineering and Research Centre  
 Panpady, Thrissur, Kerala  
 Pin: 686 011, Kerala

**NEHRU COLLEGE OF ENGINEERING & RESEARCH CENTRE**

Pampady, Thiruvilwamala, Thrissur Dt.

**DEPARTMENT OF MECHATRONICS ENGINEERING**

**WIRELESS SENSOR NETWORK**

Attendance Sheet

SL. NO.	REG. NO.	NAME OF STUDENT	29/1/16	30/1/16	1/2/16	2/2/16	3/2/16	3/2/16	4/2/16	5/2/16	6/2/16	8/2/16
1	NCANEMT001	ABHIJITH C	/	/	/	/	A	/	/	/	/	/
2	NCANEMT003	AKARSH S	A	/	/	/	/	A	/	/	/	/
3	NCANEMT006	ALOSHIOUS M DASAN	/	/	/	/	/	/	A	/	/	/
4	NCANEMT008	ANARGH VISWANATH	A	A	/	/	/	/	/	/	/	/
5	NCANEMT012	ARJUNGOPI	/	/	A	A	/	/	/	/	/	/
6	NCANEMT015	ARJUN VYSAKH C	/	/	/	/	A	/	/	A	/	/
7	NCANEMT016	ARJUN VIJAY	/	/	/	/	/	A	/	/	/	A
8	NCANEMT019	ATHUL AJITH K.	/	/	/	/	/	/	/	/	A	/
9	NCANEMT022	CIBIN JOHN JOSEPH	/	/	/	A	/	/	A	/	/	/
10	NCANEMT025	EMIL TOM	/	A	/	/	/	/	/	/	/	/
11	NCANEMT028	IRSHAD MOHAMED GHANI	/	/	/	/	/	/	/	/	/	A
12	NCANEMT032	JYOTHISH M N	A	/	/	/	/	/	/	/	/	/
13	NCANEMT034	MOHAMMED MISHAL K	/	/	A	/	/	/	/	A	/	/
14	NCANEMT036	MUHAMMED ZULFAN P B	/	/	/	/	/	/	/	A	/	/
15	NCANEMT040	RAMKUMAR	/	/	/	/	/	/	A	/	/	/
16	NCANEMT045	SHAHSAD M	/	/	A	/	/	/	/	/	/	/
17	NCANEMT047	SIDDARTH A T	A	/	/	A	/	/	/	/	/	/
18	NCANEMT050	VISHNUDAS M	/	/	/	/	A	A	/	/	/	/
19	NCANEMT054	VARSHA C K	/	/	/	/	/	/	A	/	/	/
20	NCAOEMT001	AAZTLEKHAN N	/	/	/	/	A	/	/	/	A	/
21	NCAOEMT004	ABY POIUSON	/	A	/	/	/	/	/	A	/	/
22	NCAOEMT007	AJAY AUGUSTINE	/	/	/	/	/	/	A	/	/	A
23	NCAOEMT010	AKSHAY R	/	/	/	/	/	/	/	/	A	/
24	NCAOEMT012	ALISHIHAN M S	/	/	/	/	A	/	/	/	/	/
25	NCAOEMT013	ANAND A S	/	/	A	/	/	/	/	/	/	/
26	NCAOEMT014	ANANDHU K V	/	/	/	A	/	/	/	/	/	/

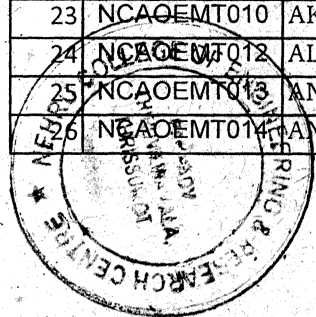

  
**PRINCIPAL**  
 Nehru College of  
 Engineering and Research Centre  
 Pampady Thiruvilwamala, Thrissur Dt.

27	NCAOEMT021	ATHUL AJITH	/	/	/	/	A	/	/	/	/	/
28	NCAOEMT026	FEMINA SHIREEN A	A	/	/	/	/	/	/	/	A	/
29	NCAOEMT031	HARIKRISHNAN N	/	/	/	/	/	/	A	/	/	/
30	NCAOEMT034	JERIN JOHN	/	/	A	/	/	/	/	/	/	A
31	NCAOEMT038	JINU P M	/	/	/	A	A	/	/	/	/	/
32	NCAOEMT042	MOHAMMED NIBRAS YOOSUF K	/	/	/	/	/	A	/	/	A	/
33	NCAOEMT043	MOYALAN JINTO JOSAN	A	/	/	/	/	/	/	A	/	/
34	NCAOEMT046	RASHAF ALI K	/	/	/	/	A	/	/	/	/	/
35	NCAOEMT049	SAJITH V	/	A	/	/	/	/	/	/	/	A
36	NCAOEMT054	SHINILNATH	/	/	/	/	A	/	/	/	/	/
37	NCAOEMT055	SIDHARTH N PISHARODY	/	/	/	/	/	/	A	/	/	/
38	NCAOEMT056	SRIRAG	/	/	/	/	/	/	/	A	/	/
39	NCAOEMT058	VISHNU K ANAND	/	A	/	/	/	/	/	/	/	/
40	NCAOEMT061	NOBLE VARGHESE	/	/	/	A	/	A	/	/	/	/
41	NCE15MC004	ADITHYA MOHAN	/	A	A	/	/	/	/	/	/	/
42	NCE15MC005	AJAY ANAND C	/	/	/	/	A	/	/	/	/	A
43	NCE15MC006	AKASH A	/	/	A	/	/	/	A	/	A	/
44	NCE15MC009	ALBIN LEO	/	/	/	A	/	/	/	/	/	/
45	NCE15MC010	ALIND ROY	A	/	/	/	A	/	/	/	/	/
46	NCE15MC017	ATHUL VAISHNAV C	A	/	/	/	/	/	/	A	/	/
47	NCE15MC019	DARIL SILVA	/	/	/	/	/	/	/	/	/	A
48	NCE15MC026	JEROM MATHEW PAUL	/	/	/	/	/	/	/	A	/	/
49	NCE15MC027	JITHIN T J	/	/	/	/	/	/	A	/	A	/
50	NCE15MC035	MARSHEL MARTIN	/	/	/	/	A	/	/	/	/	/
51	NCE15MC036	MOHAMMED HANI SHERIF	/	/	A	/	/	/	/	/	/	/

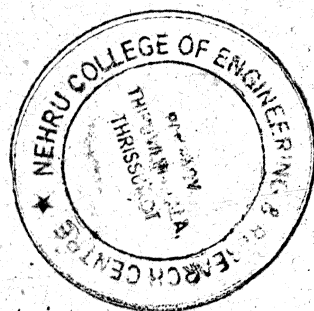

  
**PRINCIPAL**  
 Nehru College of  
 Engineering and Research Centre  
 Pampady Thiruvilwamala Thiruvananthapuram Dt  
 Pin 680 597 Kerala

52	NCE15MC037	MOHAMED JUNAID M C	A	/	/	/	/	/	/	/	/	A
53	NCE15MC043	NIRMAL C RAVINDRAN	/	/	A	/	/	/	/	A	/	/
54	NCE15MC044	RAHUL A M	/	A	/	/	/	/	/	/	A	/
55	NCE15MC050	SAGAR JOHNY C	/	/	/	A	/	A	/	/	/	/
56	NCE15MC051	SARAS MOHAN	/	/	/	/	A	/	A	/	/	/
57	NCE15MC055	SREERAG K R	/	/	/	/	/	/	/	/	/	A
58	NCE15MC056	SUDHARSHAN K	/	/	/	/	/	/	A	/	/	/
59	NCE15MC058	VISHNU P V	A	/	/	/	/	/	/	/	/	A
60	NCE15MC060	VISHNU RAJ P	A	/	/	/	/	/	/	/	/	/



PROGRAM COORDINATOR

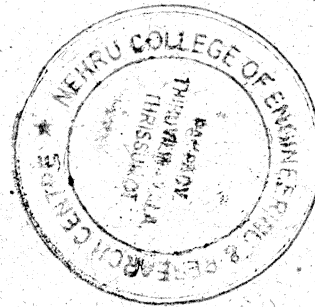
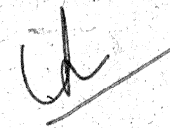

HOD

PRINCIPAL  
Nehru College of  
Engineering and Research Centre  
Paripady, Thiruvilvamala, Thiruvananthapuram  
Pin 680 597 Kerala



**NEHRU COLLEGE OF ENGINEERING AND RESEARCH CENTRE**  
(NAAC Accredited)

(Approved by AICTE, Affiliated to APJ Abdul Kalam Technological University, Kerala)  
**ADD ON COURSE ANSWER KEY**



## WIRELESS SENSOR NETWORKS

### ANSWERS

- 1 > Micro Electro Mechanical System
- 2 > both
- 3 > T
- 4 > T
- 5 > T
- 6 > gateway
- 7 > more
- 8 > 1000 to 100000
- 9 > physical
- 10 >
- 11 > physical properties, IP address
- 12 > T
- 13 > all
- 14 > 1-b 2-c 3-a
- 15 > both.
- 16 > T
- 17 > Both
- 18 > decentralised
- 19 > multihop, single hop
- 20 > a
- 21 > 2-5
- 22 > a
- 23 > larger
- 24 > both
- 25 > noise
- 26 > T
- 27 > decreases
- 28 > b
- 29 > b
- 30 > b
- 31 >  $10 \log k$
- 32 > all
- 33 > all



**PRINCIPAL**  
Nehru College of  
Engineering and Research Centre  
Pampady, Thiruvilwamala, Thirissur Dt  
Pin 680 597 Kerala

34>1-d 2-e 3-c 4-b 5-a

35> $1/\sqrt{N}$

36>increases

37>Collaborative Signal & Information Processing

38>CSIP

39>sensor networks

40>1-d 2-e 3-f 4-b 5-a 6-c

41>1-f 2-e 3-d 4-c 5-b 6-a

42>1-f 2-d 3-e 4-a 5-c 6-b

43>1-c 2-d 3-a 4-b

44> c

45>a

46>c

47>b

48>b

49>a

50>c

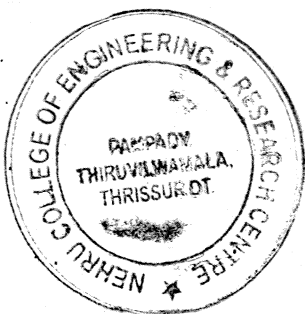

A handwritten signature in black ink, appearing to be "J. J."

PRINCIPAL  
Nehru College of  
Engineering and Research Centre  
Pampady, Thiruvilwamala, Thrissur Dt  
Pin 680 597 Kerala

Cibin John Joseph  
NCANEMTD22

86  
100



NEHRU COLLEGE OF ENGINEERING AND RESEARCH CENTRE  
(NAAC Accredited)  
(Approved by AICTE, Affiliated to APJ Abdul Kalam Technological University, Kerala)  
CERTIFICATION COURSE QUESTION PAPER



### WIRELESS SENSOR NETWORKS

- 1> MEMS stands for Micro Electro Mechanical System
- 2> A sensor network is subject to a unique set of resource constraints such as
  - a: finite on-board battery power
  - b: limited network communication bandwidthAns:            (a/b/both)
- 3> In a typical sensor network, each sensor node operates unethereed and has a microprocessor and a small amount of memory for signal processing and task scheduling (true/false) True
- 4> Each node is equipped with one or more sensing devices such as acoustic microphone arrays, video or still cameras, infrared, seismic or magnetic sensors (true/false) True
- 5> Information collected by and transmitted on a sensor network describes conditions of physical environments and requires advanced query interfaces and search engines to effectively support user-level functions (true/false) True
- 6> Gateway routes user queries or commands to appropriate nodes in a sensor network (bridge/gateway)
- 7> Communicating 1 bit over the wireless medium at short ranges consumes more energy than processing that bit (less/more)
- 8> For the Sensoria sensors and Berkeley motes, the ratio of energy consumption for communication and computation is in the range of 1000 to 100000 (100/1000/10000)
- 9> A sensor network is designed to collect information from a logical environment (logical/physical) X
- 10> Table 1.1 True
- 11> It is more appropriate to address nodes in a sensor network by physical properties than by IP address (IP address/physical properties)
- 12> Mobility and instability in wireless links prevent the use of many existing edge network gateway protocols for internetworking IP and sensor networks (true/false) True

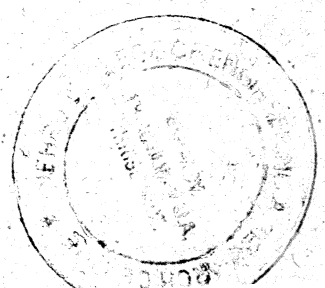

            
PRINCIPAL  
Nehru College of  
Engineering and Research Centre  
Pan-pady Thiruvilwamala, Thrissur Dt  
Pin 680 597 Kerala

13> The challenges we face in designing sensor network systems and applications include

- a: limited hardware
- b: limited support for networking
- c: limited support for software development

Ans: all (a/b/c/all)

14> Match the following 1-b, 2-c, 3-a

Limited hardware:	the tasks are typically real-time and massively distributed, involve dynamic collaboration among nodes, and must handle multiple competing events
Limited support for networking:	each node has limited processing, storage and communication capabilities, and limited energy supply and bandwidth
Limited support for software development:	the network is peer-to-peer, with a mesh topology and dynamic, mobile and unreliable connectivity

15> Following are advantages of sensor network

- a: energy advantage
- b: detection advantage

Ans: both a (a/b/both)

16> Dense networks of distributed communicating sensors can improve SNR by reducing average distances from sensor to source of signal or target (true/false) True

17> The greatest advantage of networked sensing are in improved both (robustness/scalability/both)

18> A decentralized sensing system is inherently more robust against individual sensor node or link failures, because of redundancy in the network (centralized/decentralized)

19> Because of the unique attenuation characteristics of RF signals, Multi hop network provides a significant energy saving over single hop network for the same distance (single hop/multi hop)

20> The RF attenuation model near the ground is given by

- a:  $P_{receive} \propto P_{send}/r$
- b:  $P_{send} \propto P_{receive}/p$

Ans: a (a/b/either)

21> In above expression, alpha is typically in the range of 2 to 5 (2/3/4/5)

22> The power advantage of an N-hop transmission versus a single hop transmission over the same distance  $Nr$  is

- a:  $nrf = N^{(\alpha+1)}$
- b:  $nrf = N^{(\alpha-1)}$

Ans: a (a/b/both)

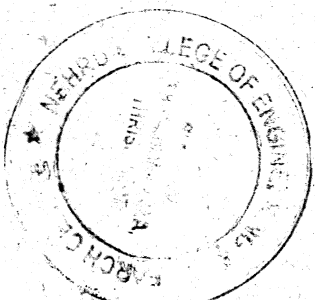

  
PRINCIPAL  
Nehru College of  
Engineering and Research Centre  
Pampady Thiruvivamala, Thiruvananthapuram Dt  
Pin 680 597 Kerala

23> In above expression, larger  $N$  gives a larger power saving due to the consideration of RF energy alone (smaller/larger)

24> Using more nodes increases

a: the cost

b: the power consumption of components

Ans: both (a/b/both)

25> Each sensor has a finite sensing range, determined by the noise floor of the sensor (ground/noise)

26> Denser sensor field improves the odds of detecting a signal source within the range (true/false) True

27> Once a signal source is inside the sensing range of a sensor, further increasing the sensor density decreases the average distance from a sensor to the signal source, hence improving the SNR (decreases/increases) X

28> wrt the acoustic sensing case in a two-dimensional plane, the acoustic power received at a distance  $r$  is given by

a:  $P_{send} \times P_{receive}/r^2$

b:  $P_{receive} \times P_{source}/r^2$

Ans: b (a/b/either)

29> Wrt acoustic sensing case in a two-dimensional plane, the SNR is given by

a:  $SNR = 10 \log P_{source} + 10 \log P_{noise} + 20 \log r$

b:  $SNR = 10 \log P_{source} - 10 \log P_{noise} - 20 \log r$

Ans: b (a/b/either)

30> The SNR advantage of the denser sensor network is given by

a:  $nsnr = 20 \log k$  X

b:  $nsnr = 10 \log k$

Ans: b (a/b/either)

31> An increase in sensor density by a factor of  $k$  improves the SNR at a sensor by 10 log k / 20 log k

32> A sensor network is designed to perform a set of high level information processing tasks such as

a: detection

b: tracking

c: classification

Ans: all (a/b/c/all)

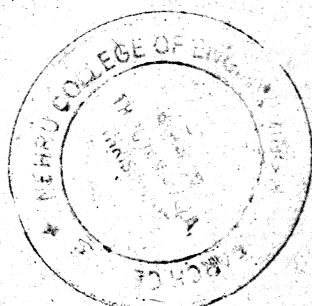

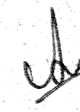
  
PRINCIPAL  
Nehru College of  
Engineering and Research Centre  
Pampady, Thiruvilwamala, Thiruvananthapuram Dt  
Pin - 680 597, Kerala

33> Following are sample commercial and military applications include

- a: environmental monitoring
- b: industrial sensing and diagnostics
- c: infrastructure protection
- d: battlefield awareness
- e: context aware computing

Ans: all (a/b/c/d/e/all)

34> Match the following

1 - d 2 - a 3 - c 4 - b 5 - e

environmental monitoring	: intelligent home, responsive environment
Industrial sensing and diagnostics	: multi-target tracking
Infrastructure protection	: power grids, water distribution
Battlefield awareness	: traffic, habitat, security
Context aware computing	: appliances, factory, supply chains

35> If every sensor has some data that it needs to send to another node in a network, then per node throughput scales as  $\frac{1}{\sqrt{N}}$  ( $\sqrt{N}$  or  $1/\sqrt{N}$ )

36> As the number of nodes increases, every node spends almost all of its time forwarding packets of other nodes (decreases/increases)

37> CSIP stands for Collaborative Signal & Information Processing

38> CSIP refers to signal and information processing problems dominated by the issue of selecting embedded sensors to participate in an information processing task (CSIP/CCIP)

39> sensor networks is an interdisciplinary research area that draws on contributions from signal processing, networking and protocols, databases and information management, distributed algorithms, and embedded systems and architecture (wireless networks/sensor networks)

40> Match the following 1 - d 2 - e 3 - f 4 - b 5 - a 6 - c

sensor:	routing of data based on geographical attributes such as locations or regions
sensor node:	the process of determining a network path from a packet source node to its destination
network topology:	approaches that name, route or access a piece of data, a properties that are external to a communication network
routing:	a transducer that converts a physical phenomenon that may be further manipulated by other apparatus
data centric:	a basic unit with on-board sensors, processor, memory, wireless modem and power supply
geographic routing:	a connectivity graph where nodes are sensor nodes and edges are communication links

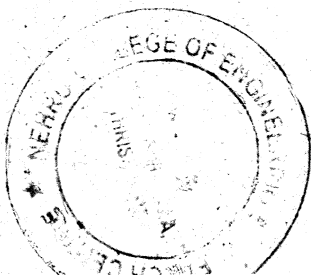

*Ud*  
**PRINCIPAL**  
 Nehru College of  
 Engineering and Research Centre  
 Pampady, Thiruvananthapuram, Thiruvananthapuram Dt  
 Pin - 680 597 Kerala

41 > Match the following

1-f 2-e 3-d 4-c 5-b 6-a

In-network:	the process of discovering the existence of a physical phenomenon
Collaborative processing:	either high-level system tasks which may include sensing, communication, processing and resource allocation or application tasks which may include detection, classification, localization and tracking
State:	a condition of the information caused by noise in sensor measurements or lack of knowledge in models
Uncertainty:	a snapshot about a physical environment or a snapshot of the system itself
Task:	sensors cooperatively processing data from multiple sources in order to serve a high level task
Detection:	a style of processing in which the data is processed and combined near where the data is generated

42 > Match the following

Classification:	the assignment of sensors to a particular task and the control of sensor state for accomplishing the task
Localization & tracking:	services such as time synchronization and node localization that enable applications to discover properties of a node and the nodes to organize themselves into a useful network
Value of information:	resources include sensors, communication links, processors, on-board memory and node energy reserves
Sensor tasking:	the estimation of the state of a physical entity such as a physical phenomenon or a sensor node from a set of measurements
Resource:	a mapping of data to a scalar number, in the context of the overall system task and knowledge
Node services:	the assignment of class labels to a set of physical phenomena being observed

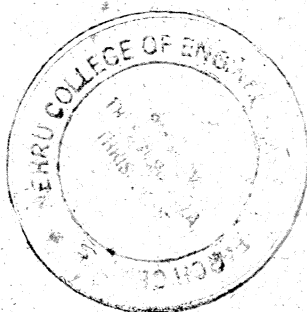

*[Signature]*  
**PRINCIPAL**  
 Nehru College of  
 Engineering and Research Centre  
 Panipady Thiruvananthapuram, Thiruvananthapuram  
 Pin 680 597 Kerala

43> Match the following

1-c 2-d 3-a 4-b

Data storage:	the abstract characterization of system properties
Embedded OS:	a measurable quantity that describes how well the system is performing on some absolute scale
System performance goal:	sensor information is stored, indexed and accessed by applications.
Evaluation metric:	the run-time system support for sensor network applications

44> Ad hoc wireless networks can be very useful in establishing \_\_\_\_\_ among a group of soldiers for tactical operations. ( )

- (a) Communication (b) Information (c) Network channel (d) DCN

45> MANET does not face the challenge of ( )

- (a) Security (b) Node cooperation (c) QoS (d) Quick network setup

46> This mode of wireless network allows devices to communicate directly with each other.

- (a) Ad-hoc (b) Digital (c) Physical (d) Infrastructure

47> A \_\_\_\_\_ is self-created when roaming wireless devices are connected over a wireless link.

- (a) MANET (b) WPAN (c) DARPA (d) NTDR

48> RTS/CTS period is called ( )

- (a) Waiting period (b) Contention period (c) Running period (d) none of these

49> Existing MAC protocols cannot be used in MANETs because of ( )

- (a) Resource constrained nodes (b) Limited bandwidth (c) Lack of centralized control (d) All of the above

50> MARCH exploits the properties of \_\_\_\_\_ antennas and overhearing properties of MANETs. ( )

- (a) Single directional (b) Bi-directional (c) Omnidirectional (d) None of these

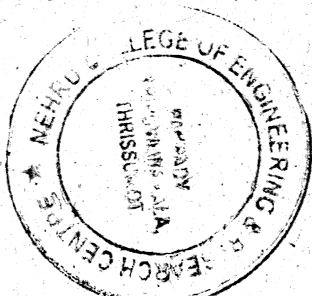

  
PRINCIPAL  
Nehru College of  
Engineering and Research Centre  
Pattipady, Thiruvilwamala, Thiruvananthapuram  
Kerala

Mohammed Junaid  
NCE15MC037

56  
100



NEHRU COLLEGE OF ENGINEERING AND RESEARCH CENTRE  
(NAAC Accredited)  
(Approved by AICTE, Affiliated to APJ Abdul Kalam Technological University, Kerala)  
CERTIFICATION COURSE QUESTION PAPER



## WIRELESS SENSOR NETWORKS

1> MEMS stands for Micro electro Mechanical System

2> A sensor network is subject to a unique set of resource constraints such as

a: finite on-board battery power

b: limited network communication bandwidth

Ans:                      (a/b/both)

3> In a typical sensor network, each sensor node operates unetheread and has a microprocessor and a small amount of memory for signal processing and task scheduling (true/false)                     

4> Each node is equipped with one or more sensing devices such as acoustic microphone arrays, video or still cameras, infrared, seismic or magnetic sensors (true/false)                      X

5> Information collected by and transmitted on a sensor network describes conditions of physical environments and requires advanced query interfaces and search engines to effectively support user-level functions (true/false)                      X

6>                      routes user queries or commands to appropriate nodes in a sensor network (bridge/gateway)

7> Communicating 1 bit over the wireless medium at short ranges consumes                      energy than processing that bit (less/more) X

8> For the Sensoria sensors and Berkeley motes, the ratio of energy consumption for communication and computation is in the range of 100 to 1000 (100/1000/10000) X

9> A sensor network is designed to collect information from a                      environment (logical/physical)

10> Table 1.1 True

11> It is more appropriate to address nodes in a sensor network by Physical than by IP (IP address/physical properties) X

12> Mobility and instability in wireless links prevent the use of many existing edge network gateway protocols for internetworking IP and sensor networks (true/false)                      X

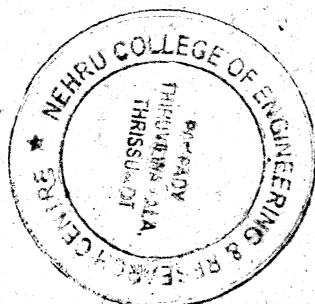

PRINCIPAL

Nehru College of  
Engineering and Research Centre  
Panipady, Thiruvilwamala, Thiruvananthapuram  
Pin 680 597 Kerala

13> The challenges we face in designing sensor network systems and applications include:

- a: limited hardware
- b: limited support for networking
- c: limited support for software development

Ans: \_\_\_\_\_ (a/b/c/all)

1 - c    2 - b    3 - a

14> Match the following

Limited hardware:	the tasks are typically real-time and massively distributed, involve dynamic collaboration among nodes, and must handle multiple competing events
Limited support for networking:	each node has limited processing, storage and communication capabilities, and limited energy supply and bandwidth
Limited support for software development:	the network is peer-to-peer, with a mesh topology and dynamic, mobile and unreliable connectivity

15> Following are advantages of sensor network

- a: energy advantage
- b: detection advantage

Ans: \_\_\_\_\_ (a/b/both)

16> Dense networks of distributed communicating sensors can improve SNR by reducing average distances from sensor to source of signal or target (true/false) \_\_\_\_\_

17> The greatest advantage of networked sensing are in improved \_\_\_\_\_ (robustness/scalability/both)

18> A \_\_\_\_\_ sensing system is inherently more robust against individual sensor node or link failures, because of redundancy in the network (centralized/decentralized)

19> Because of the unique attenuation characteristics of RF signals, \_\_\_\_\_ network provides a significant energy saving over \_\_\_\_\_ network for the same distance (single hop/multi hop)

20> The RF attenuation model near the ground is given by

- a:  $P_{receive} \propto P_{send}/r$
- b:  $P_{send} \propto P_{receive}/p$

Ans: \_\_\_\_\_ (a/b/either)

21> In above expression, alpha is typically in the range of 2 to 5 (2/3/4/5)

22> The power advantage of an N-hop transmission versus a single hop transmission over the same distance  $Nr$  is

- a:  $nrf = N^{(\alpha-1)}$
- b:  $nrf = N^{(\alpha+1)}$

Ans: \_\_\_\_\_ (a/b/both)

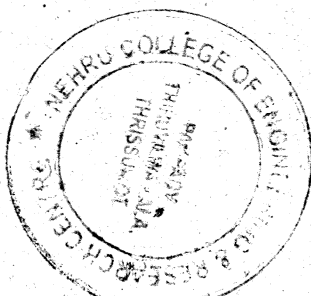

*[Signature]*

**PRINCIPAL**  
Nehru College of  
Engineering and Research Centre  
Panipady, Thiruvilwamala, Thiruvananthapuram Dt  
Pin - 680 597, Kerala

23> In above expression, \_\_\_\_\_ N gives a larger power saving due to the consideration of RF energy alone (smaller/larger)

24> Using more nodes increases

a: the cost

b: the power consumption of components

Ans: \_\_\_\_\_ (a/b/both)

25> Each sensor has a finite sensing range, determined by the \_\_\_\_\_ floor of the sensor (ground/noise)

26> Denser sensor field improves the odds of detecting a signal source within the range (true/false).

27> Once a signal source is inside the sensing range of a sensor, further increasing the sensor density \_\_\_\_\_ the average distance from a sensor to the signal source, hence improving the SNR (decreases/increases)

28> Wrt the acoustic sensing case in a two-dimensional plane, the acoustic power received at a distance r is given by

a:  $P_{send} \times P_{receive}/r^2$

b:  $P_{receive} \times P_{source}/r^2$

Ans: \_\_\_\_\_ (a/b/either)

29> Wrt acoustic sensing case in a two-dimensional plane, the SNR is given by

a:  $SNR = 10 \log P_{source} + 10 \log P_{noise} + 20 \log r$

b:  $SNR = 10 \log P_{source} - 10 \log P_{noise} - 20 \log r$

Ans: \_\_\_\_\_ (a/b/either)

30> The SNR advantage of the denser sensor network is given by

a:  $nsnr = 20 \log k$

b:  $nsnr = 10 \log k$

Ans: \_\_\_\_\_ (a/b/either)

31> An increase in sensor density by a factor of k improves the SNR at a sensor by \_\_\_\_\_ db (10 log k / 20 log k)

32> A sensor network is designed to perform a set of high level information processing tasks

a: detection

b: tracking

c: classification

Ans: \_\_\_\_\_ (a/b/c/all)

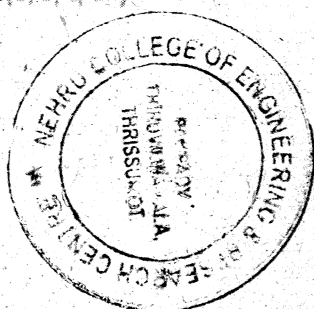

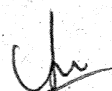
  
PRINCIPAL  
Nehru College of  
Engineering and Research Centre  
Pampady, Thiruvithamala, Thrissur Dt.  
Pin 686-597, Kerala

33> Following are sample commercial and military applications include

- a: environmental monitoring
- b: industrial sensing and diagnostics
- c: infrastructure protection
- d: battlefield awareness
- e: context aware computing

Ans: \_\_\_\_\_ (a/b/c/d/e/all)

1-e 2-d 3-c 4-b 5-a

34> Match the following

- environmental monitoring : intelligent home, responsive environment
- Industrial sensing and diagnostics : multi-target tracking
- Infrastructure protection : power grids, water distribution
- Battlefield awareness : traffic, habitat, security
- Context aware computing : appliances, factory, supply chains

35> If every sensor has some data that it needs to send to another node in a network, the total network throughput scales as \_\_\_\_\_ ( $\sqrt{N}$  or  $1/\sqrt{N}$ )

36> As the number of nodes \_\_\_\_\_, every node spends almost all of its time forwarding packets of other nodes (decreases/increases)

37> CSIP stands for \_\_\_\_\_

38> CSIP refers to signal and information processing problems dominated by the issue of selecting embedded sensors to participate in an information processing task (CSIP/CCIP)

39> \_\_\_\_\_ is an interdisciplinary research area that draws on computer science, signal processing, networking and protocols, databases and information management, distributed algorithms, and embedded systems and architecture (wireless networks/sensor networks)

40> Match the following 1-d 2-e 3-f 4-b 5-a 6-c

sensor:	routing of data based on geographical attributes such as locations or regions
sensor node:	the process of determining a network path from a packet source node to its destination
network topology:	approaches that name, route or access a piece of data via properties that are external to a communication network
routing:	a transducer that converts a physical phenomenon that may be further manipulated by other apparatus
data centric:	a basic unit with on-board sensors, processor, memory, wireless modem and power supply
geographic routing:	a connectivity graph where nodes are sensor nodes and edges are communication links

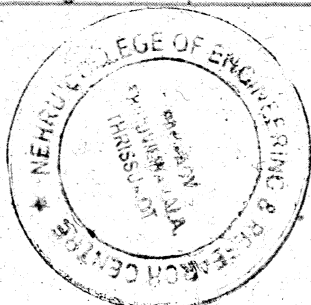

*Uho*

PRINCIPAL  
Nehru College of Engineering and Research Centre  
Panpady, Thiruvananthapuram, Thiruvananthapuram Dt  
Kerala

41) Match the following 1-f 2-e 3-d 4-c 5-b 6-a

In-network:	the process of discovering the existence of a physical phenomenon
Collaborative processing:	either high-level system tasks which may include sensing, communication, processing and resource allocation or application tasks which may include detection, classification, localization or tracking
State:	a condition of the information caused by noise in sensor measurements or lack of knowledge in models
Uncertainty:	a snapshot about a physical environment or a snapshot of the system itself
Task:	sensors cooperatively processing data from multiple sources in order to serve a high level task
Detection:	a style of processing in which the data is processed and compared near where the data is generated

42) Match the following 1-f 2-d 3-e 4-a 5-c 6-b

Classification:	the assignment of sensors to a particular task and the control of sensor state for accomplishing the task
Localization & tracking:	services such as time synchronization and node localization that enable applications to discover properties of a node and the nodes to organize themselves into a useful network
Value of information:	resources include sensors, communication links, processors, on-board memory and node energy reserves
Sensor tasking:	the estimation of the state of a physical entity such as a physical phenomenon or a sensor node from a set of measurements
Resource:	a mapping of data to a scalar number in the context of the overall system task and knowledge
Node services:	the assignment of class labels to a set of physical phenomena being observed

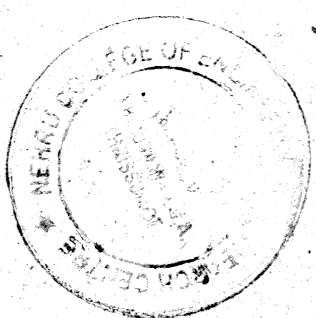

*U*  
**PRINCIPAL**  
 NERU College of  
 Engineering and Research Centre  
 Panpady, Thiruvananthapuram, Thiruvananthapuram Dt.  
 Pin - 686 597 Kerala

43> Match the following

1-c 2-d 3-a 4-b

Data storage:	the abstract characterization of system properties.
Embedded OS:	a measurable quantity that describes how well the system is performing on some absolute scale
System performance goal:	sensor information is stored, indexed and accessed by applications
Evaluation metric:	the run-time system support for sensor network applications

44> Ad hoc wireless networks can be very useful in establishing \_\_\_\_\_ among a group of soldiers for tactical operations. ( )

- (a) Communication (b) Information (c) Network channel (d) DCN

45> MANET does not face the challenge of ( )

- (a) Security (b) Node cooperation (c) QoS (d) Quick network setup

46> This mode of wireless network allows devices to communicate directly with each other.

- (a) Ad-hoc (b) Digital (c) Physical (d) Infrastructure

47> A \_\_\_\_\_ is self-created when roaming wireless devices are connected over a wireless link.

- (a) MANET (b) WPAN (c) DARPA (d) NTDR

48> RTS/CTS period is called ( )

- (a) Waiting period (b) Contention period (c) Running period (d) none of these

49> Existing MAC protocols cannot be used in MANETs because of ( )

- (a) Resource constrained nodes (b) Limited bandwidth (c) Lack of centralized control (d) All of the above

50> MARCH exploits the properties of \_\_\_\_\_ antennas and overhearing properties of MANETs. ( )

- (a) Single directional (b) Bi-directional (c) Omnidirectional (d) None of these

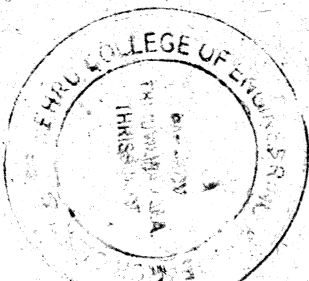

  
PRINCIPAL  
Nehru College of  
Engineering and Research Centre  
Panipady Thiruvilwamala, Thrissur Dt  
Pin - 680 597 Kerala

14  
100



NEHRU COLLEGE OF ENGINEERING AND RESEARCH CENTRE  
(NAAC Accredited)  
(Approved by AICTE, Affiliated to APJ Abdul Kalam Technological University, Kerala)  
CERTIFICATION COURSE QUESTION PAPER



### WIRELESS SENSOR NETWORKS

1> MEMS stands for MICRO ELECTRO MECHANICAL SYSTEM

2> A sensor network is subject to a unique set of resource constraints such as

- a: finite on-board battery power
- b: limited network communication bandwidth

Ans: (a/b/both)

3> In a typical sensor network, each sensor node operates unethereed and has a microprocessor and a small amount of memory for signal processing and task scheduling (true/false) X

4> Each node is equipped with one or more sensing devices such as acoustic microphone arrays, video or still cameras, infrared, seismic or magnetic sensors (true/false) X

5> Information collected by and transmitted on a sensor network describes conditions of physical environments and requires advanced query interfaces and search engines to effectively support user-level functions (true/false) X

6> bridge/gateway routes user queries or commands to appropriate nodes in a sensor network (bridge/gateway) X

7> Communicating 1 bit over the wireless medium at short ranges consumes less/more energy than processing that bit (less/more) X

8> For the Sensoria sensors and Berkeley motes, the ratio of energy consumption for communication and computation is in the range of 100 to 1000 (100/1000/10000) X

9> A sensor network is designed to collect information from a logical/physical environment (logical/physical) X

10> Table 1.1 False X

11> It is more appropriate to address nodes in a sensor network by IP than by Physical (IP address/physical properties) X

12> Mobility and instability in wireless links prevent the use of many existing edge network gateway protocols for internetworking IP and sensor networks (true/false) X

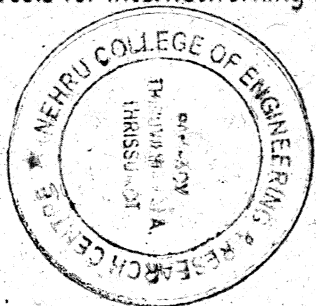

CAJ  
PRINCIPAL  
Nehru College of  
Engineering and Research Centre  
Pampady Thiruvilwamala Thiruvananthapuram Dt  
Pin - 680 597 Kerala

13> The challenges we face in designing sensor network systems and applications include

- a: limited hardware
- b: limited support for networking
- c: limited support for software development

Ans: \_\_\_\_\_ (a/b/c/all)

14> Match the following 1-c 2-b 3-a

Limited hardware:	the tasks are typically real-time and massively distributed, involve dynamic collaboration among nodes, and must handle multiple competing events
Limited support for networking:	each node has limited processing, storage and communication capabilities, and limited energy supply and bandwidth
Limited support for software development:	the network is peer-to-peer, with a mesh topology and dynamic, mobile and unreliable connectivity

15> Following are advantages of sensor network

- a: energy advantage
- b: detection advantage

Ans: \_\_\_\_\_ (a/b/both)

16> Dense networks of distributed communicating sensors can improve SNR by reducing average distances from sensor to source of signal or target (true/false) \_\_\_\_\_

17> The greatest advantage of networked sensing are in improved \_\_\_\_\_ (robustness/scalability/both)

18> A \_\_\_\_\_ sensing system is inherently more robust against individual sensor node or link failures, because of redundancy in the network (centralized/decentralized)

19> Because of the unique attenuation characteristics of RF signals, \_\_\_\_\_ network provides a significant energy saving over \_\_\_\_\_ network for the same distance (single hop/multi hop)

20> The RF attenuation model near the ground is given by

a:  $P_{receive} \propto P_{send}/r$

b:  $P_{send} \propto P_{receive}/p^r$

Ans: \_\_\_\_\_ (a/b/either)

21> In above expression, alpha is typically in the range of 4 to 5 (2/3/4/5)

22> The power advantage of an N-hop transmission versus a single hop transmission over the same distance  $Nr$  is

a:  $nrf = N^{(\alpha-1)}$

b:  $nrf = N^{(\alpha+1)}$

Ans: \_\_\_\_\_ (a/b/both)

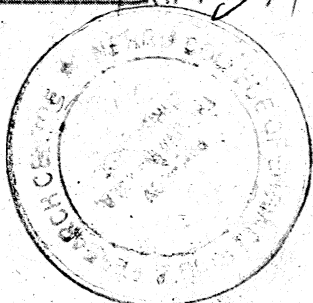

PRINCIPAL  
N. S. S. Pillai  
Engineering and Research Centre  
Pappady, Thrissur Dt, Kerala  
Pin - 686 597, Kerala

23> In above expression, \_\_\_\_\_,  $N$  gives a larger power saving due to the consideration of RF energy alone (smaller/larger) X

24> Using more nodes increases

a: the cost

b: the power consumption of components

Ans: \_\_\_\_\_ (a/b/both) X

25> Each sensor has a finite sensing range determined by the \_\_\_\_\_ (ground/noise) X

26> Denser sensor field improves the odds of detecting a signal source within the range (true/false) X

27> Once a signal source is inside the sensing range of a sensor, further increasing the sensor density \_\_\_\_\_ the average distance from a sensor to the signal source, hence improving the SNR (decreases/increases) X

28> wrt the acoustic sensing case in a two-dimensional plane, the acoustic power received at a distance  $r$  is given by

a:  $P_{send} \times P_{receive}/r^2$

b:  $P_{receive} \times P_{source}/r^2$  X

Ans: \_\_\_\_\_ (a/b/either)

29> Wrt acoustic sensing case in a two-dimensional plane, the SNR is given by

a:  $SNR = 10 \log P_{source} + 10 \log P_{noise} + 20 \log r$

b:  $SNR = 10 \log P_{source} - 10 \log P_{noise} - 20 \log r$  X

Ans: \_\_\_\_\_ (a/b/either)

30> The SNR advantage of the denser sensor network is given by

a:  $nsnr = 20 \log k$

b:  $nsnr = 10 \log k$  X

Ans: \_\_\_\_\_ (a/b/either)

31> An increase in sensor density by a factor of  $k$  improves the SNR at a sensor by \_\_\_\_\_ db (10 log k / 20 log k) X

32> A sensor network is designed to perform a set of high level information processing tasks such as

a: detection

b: tracking

c: classification

Ans: \_\_\_\_\_ (a/b/c/all) X

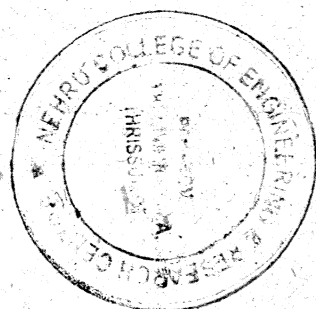

**PRINCIPAL**  
Nehru College of  
Engineering and Research Centre  
Panipady Thiruvilwamala, Thiruvananthapuram Dt.  
Pin 680 597 Kerala

33> Following are sample commercial and military applications include

- a: environmental monitoring
- b: industrial sensing and diagnostics
- c: infrastructure protection
- d: battlefield awareness
- e: context aware computing

Ans: \_\_\_\_\_ (a/b/c/d/e/all) X

34> Match the following

1-e 2-d 3-b 4-c 5-a

environmental monitoring	: intelligent home, responsive environment
Industrial sensing and diagnostics	: multi-target tracking
Infrastructure protection	: power grids, water distribution
Battlefield awareness	: traffic, habitat, security
Context aware computing	: appliances, factory, supply chains X

35> If every sensor has some data that it needs to send to another node in a network then the network throughput scales as \_\_\_\_\_ ( $\sqrt{N}$  or  $1/\sqrt{N}$ ) X

36> As the number of nodes \_\_\_\_\_, every node spends almost all of its time forwarding packets of other nodes (decreases/increases) X

37> CSIP stands for COLLABORATIVE SIGNAL AND INFORMATION PROCESSING

38> \_\_\_\_\_ refers to signal and information processing problems dominated by the issue of selecting embedded sensors to participate in an information processing task CSIP/CSIP

39> \_\_\_\_\_ is an interdisciplinary research area that draws on contributions from signal processing, networking and protocols, databases and information management, distributed algorithms, and embedded systems and architecture (wireless networks/sensor networks)

40> Match the following 1-e 2-d 3-b 4-f 5-a 6-c

sensor:	routing of data based on geographical attributes such as locations or regions
sensor node:	the process of determining a network path from a packet source node to its destination
network topology:	approaches that name, route or access a piece of data; properties that are external to a communication network
routing:	a transducer that converts a physical phenomenon that may be further manipulated by other apparatus
data centric:	a basic unit with on-board sensors, processor, memory, wireless modem and power supply
geographic routing:	a connectivity graph where nodes are sensor nodes and edges are communication links

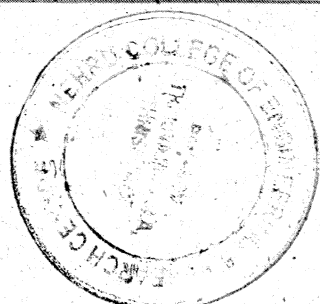

PRINCIPAL  
Nehru College of  
Engineering and Research Centre  
Pampady, Thrissur Dt, Kerala  
Pin 680 597 Kerala

41> Match the following : 1-e 2-f 3-c 4-d 5-a 6-b

In-network:	the process of discovering the existence of a physical phenomenon
Collaborative processing:	either high-level system tasks which may include sensing, communication, processing and resource allocation or application tasks which may include detection, classification, localization or tracking
State:	a condition of the information caused by noise in sensor measurements or lack of knowledge in models
Uncertainty:	a snapshot about a physical environment or a snapshot of the system itself
Task:	sensors cooperatively processing data from multiple sources in order to serve a high level task
Detection:	a style of processing in which the data is processed and combined near where the data is generated

42> Match the following : 1-f 2-e 3-c 4-d 5-b 6-a

Classification:	the assignment of sensors to a particular task and the control of sensor state for accomplishing the task
Localization & tracking:	services such as time synchronization and node localization that enable applications to discover properties of a node and the nodes to organize themselves into a useful network
Value of information:	resources include sensors, communication links, processors, on-board memory and node energy reserves
Sensor tasking:	the estimation of the state of a physical entity such as a physical phenomenon or a sensor node from a set of measurements
Resource:	a mapping of data to a scalar number, in the context of the overall system task and knowledge
Node services:	the assignment of class labels to a set of physical phenomena being observed

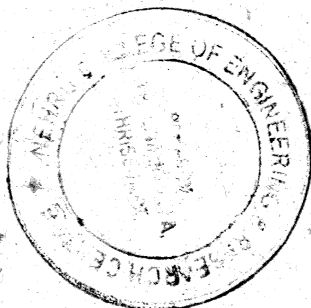

  
**PRINCIPAL**  
 Nehru College of  
 Engineering and Research Centre  
 Panipady Thiruvilwamala, Thiruvananthapuram Dt.  
 Pin 680 597 Kerala

43> Match the following

1 - d 2 - c 3 - b 4 - a

Data storage:	the abstract characterization of system properties
Embedded OS:	a measurable quantity that describes how well the system is performing on some absolute scale
System performance goal:	sensor information is stored, indexed and accessed by applications
Evaluation metric:	the run-time system support for sensor network applications

44> Ad hoc wireless networks can be very useful in establishing \_\_\_\_\_ among a group of soldiers for tactical operations. ( )

- (a) Communication (b) Information (c) Network channel (d) DCN

45> MANET does not face the challenge of ( )

- (a) Security (b) Node cooperation (c) QoS (d) Quick network setup

46> This mode of wireless network allows devices to communicate directly with each other

- (a) Ad-hoc (b) Digital (c) Physical (d) Infrastructure

47> A \_\_\_\_\_ is self-created when roaming wireless devices are connected over a wireless link.

- (a) MANET (b) WPAN (c) DARPA (d) NTDR

48> RTS/CTS period is called ( )

- (a) Waiting period (b) Contention period (c) Running period (d) none of these

49> Existing MAC protocols cannot be used in MANETs because of ( )

- (a) Resource constrained nodes (b) Limited bandwidth (c) Lack of centralized control (d) All of the above

50> MARCH exploits the properties of \_\_\_\_\_ antennas and overhearing properties of MANETs. ( )

- (a) Single directional (b) Bi-directional (c) Omnidirectional (d) None of these

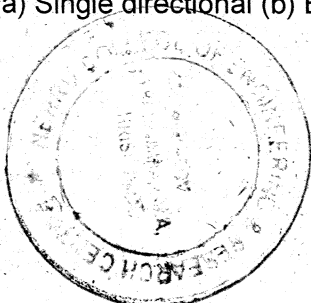

PRINCIPAL  
Nehru College of  
Engineering and Research Centre  
Pampady Thiruvilwamala, Thrissur Dt.  
Pin 680 597 Kerala



**NEHRU COLLEGE OF ENGINEERING AND RESEARCH CENTRE**  
(NAAC Accredited)  
(Approved by AICTE, Affiliated to APJAKTU & Calicut University, Kerala)  
ACADAMIC YEAR (2015-16)



**DEPARTMENT OF MECHATRONICS ENGINEERING**  
**OFFERING CERTIFIED COURSE ON**  
**WIRELESS SENSOR NETWORKS**

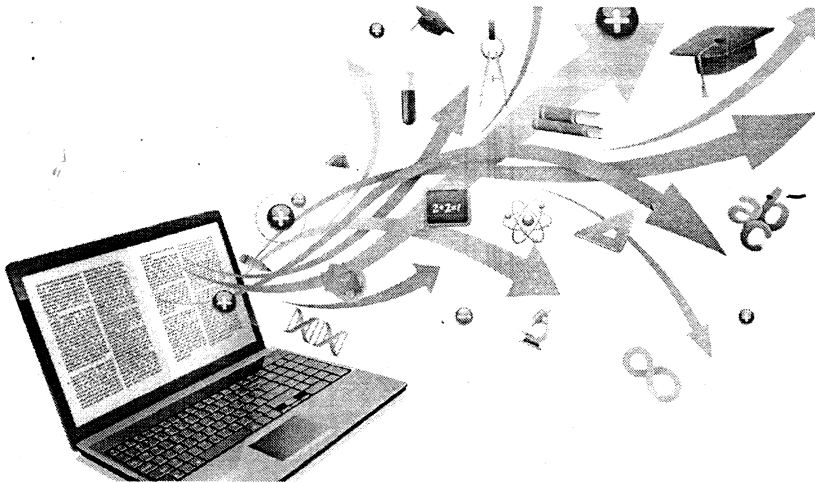

**COURSE POINTS**

- ✓ AD HOC NETWORKS
- ✓ SENSOR NETWORKS
- ✓ SENSOR NETWORK SECURITY
- ✓ SENSOR NETWORK PLATFORMS AND TOOLS

**FACULTY**

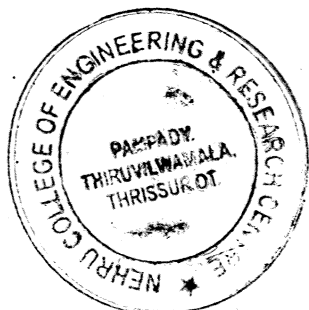

  
**PRINCIPAL**  
Nehru College of  
Engineering and Research Centre  
Pampady Thiruvilwamala Thrissur Dt  
Pin 680 597 Kerala



# Certificate OF COMPLETION

..... AKARSH S (NCA NEMT 003) ..... had successfully completed  
the Certified course "WIRELESS SENSOR NETWORKS" during 2015-16 conducted by the  
Department of Mechatronics Engineering, Nehru College of Engineering and  
Research Centre, Pampady, Thrissur.

PROGRAM CO-ORDINATOR

HEAD OF DEPARTMENT

PRINCIPAL

Nehru College of  
Engineering and Research Centre  
Pampady, Thrissur

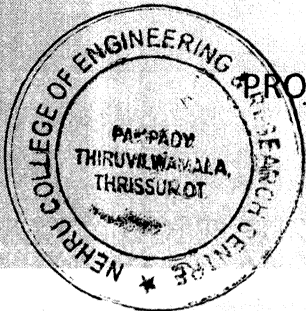



# Certificate OF COMPLETION

.....AKSHAY R (NCAOEMTOIO).....had successfully completed  
the Certified course "WIRELESS SENSOR NETWORKS" during 2015-16 conducted by the  
Department of Mechatronics Engineering, Nehru College of Engineering and  
Research Centre, Pampady, Thrissur.

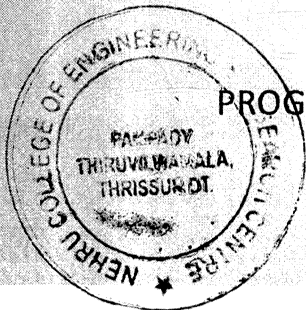

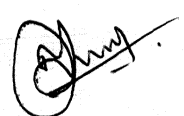
  
PROGRAM CO-ORDINATOR



  
HEAD OF DEPARTMENT

Principal  
Nehru College of  
Engineering and Research Centre  
Pampady, Thrissur  
980 597 Kerala



# Certificate OF COMPLETION

.....ALIND ROY (NCE15MCO10).....had successfully completed  
the Certified course "WIRELESS SENSOR NETWORKS" during 2015-16 conducted by the  
Department of Mechatronics Engineering, Nehru College of Engineering and  
Research Centre, Pampady, Thrissur.

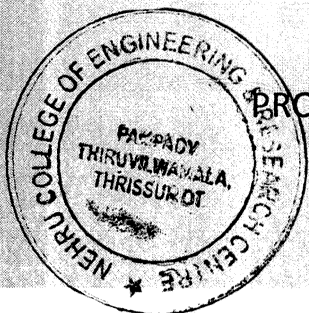

PROGRAM CO-ORDINATOR

HEAD OF DEPARTMENT

PRINCIPAL

Nehru College of  
Engineering and Research  
Pampady, Thrissur  
Pin - 680 097 Kerala



# Certificate OF COMPLETION

..... SHINIL NATH (NCAOEMT054)..... had successfully completed  
the Certified course "WIRELESS SENSOR NETWORKS" during 2015-16 conducted by the  
Department of Mechatronics Engineering, Nehru College of Engineering and  
Research Centre, Pampady, Thrissur.

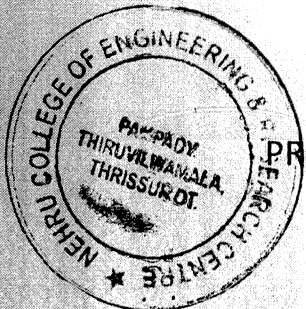

PROGRAM CO-ORDINATOR

HEAD OF DEPARTMENT PRINCIPAL

Nehru College  
Engineering and Research Centre  
Pampady, Thrissur  
680 597 Kerala



**NEHRU COLLEGE OF ENGINEERING AND RESEARCH CENTRE  
(NAAC Accredited)**

(Approved by AICTE, Affiliated to APJ Abdul Kalam Technological University, Kerala)



# MBA



# Certificate OF COMPLETION

.....SRIRAM (NCAOEMT056).....had successfully completed  
the Certified course "WIRELESS SENSOR NETWORKS" during 2015-16 conducted by the  
Department of Mechatronics Engineering, Nehru College of Engineering and  
Research Centre, Pampady, Thrissur.

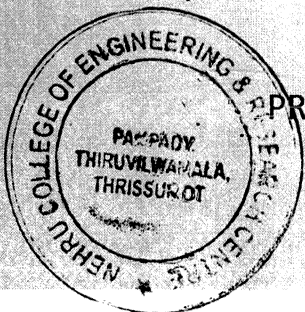

PROGRAM CO-ORDINATOR

HEAD OF DEPARTMENT

PRINCIPAL  
Nehru College of  
Engineering and Research Centre  
Pampady, Thiruvilwamala, Thrissur  
Pin 686 565 Kerala



NEHRU COLLEGE OF ENGINEERING AND RESEARCH CENTRE  
NEHRU SCHOOL OF MANAGEMENT  
NILA GARDENS, PAMPADY



NSM/Academic/2016/15

06/01/2016

**CIRCULAR**

This is to inform all the students that Nehru School of Management is organizing a certificate program in MS Office for the management students at Kapila on the 9<sup>th</sup>, 16<sup>th</sup>, 23<sup>rd</sup> and 30<sup>th</sup> January 2016. All are invited to participate.

Director,

Nehru School of Management

CC:

The Principal, NCERC  
Campus Manager, NCERC  
Academic Office, NCERC

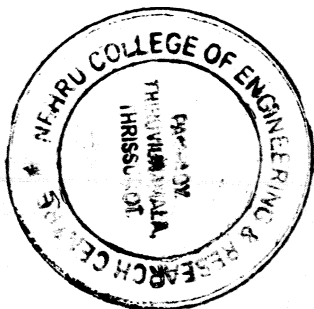

**PRINCIPAL**

Nehru College of  
Engineering and Research Centre  
Pampady Thiruvilwamala, Thiruvananthapuram  
Pin 680 597 Kerala



NEHRU COLLEGE OF ENGINEERING AND RESEARCH CENTRE  
NEHRU SCHOOL OF MANAGEMENT  
NILA GARDENS, PAMPADY



NSM/Academic/2015/23

7<sup>th</sup> May 2015

Yearly Academic Meeting

Minutes

Point Discussed	Action taken	Responsibility
Academics quality	To create clear academic calendar and audit	Ms. Chandrakala
Academic Time table	<ul style="list-style-type: none"><li>To prepare timetable and to be circulated.</li><li>All the documents to be filed.</li></ul>	Ms Chandrakala
Admission Work	To be done as per need	Dr. Raj
Certificate Program	To organize a certificate program on MS office	Director Mr. Alex
Refresher Course	To organize a refresher course in strategic Management	Ms. Chandrakala
Training Program	To organize a training and development in Research problem and area identification in social science	Mr. Dinesh

Members

Director NSM:

Dr. KVS Raj

Ms. Chandrakala:

Academic Coordinator

Nehru School of Management

CC:

The Principal, NCERC

Campus Manager, NCERC

Academic Office, NCERC

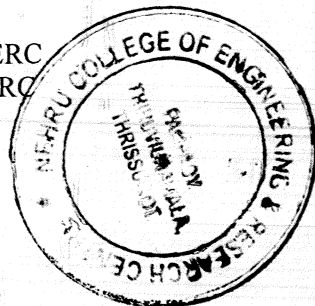

Director,

Nehru School of Management

**PRINCIPAL**

Nehru College of

Engineering and Research Cent:

Pampady Thiruvilwamala, Thrissur Dt

Pin 680 597 Kerala



NEHRU COLLEGE OF ENGINEERING AND RESEARCH CENTRE  
NEHRU SCHOOL OF MANAGEMENT  
NILA GARDENS, PAMPADY



NSM/Academic/2016/45

4<sup>th</sup> Jan 2016

To,

The Principal,  
NCERC, Pampady

Dear Madam,

**Sub: Request to conduct Certificate course in MS office**

We are planning to organize a certificate course in MS office for the students of MBA on January 9<sup>th</sup>, 16<sup>th</sup>, 23<sup>rd</sup> and 30<sup>th</sup>. We kindly request you to approve it. The resource person is Dr. Sudheer Marar.

Thanking You,

*Approved*  
*Ashwin*

Director,

Nehru School of Management

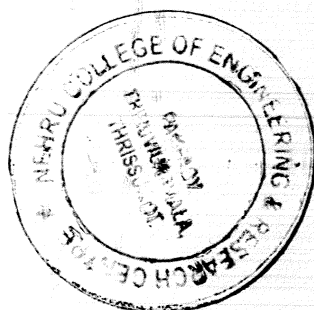

**PRINCIPAL**  
Nehru College of  
Engineering and Research Centre  
Pampady Thiruvilwamala Thirissur Dt  
Pin 680 597 Kerala



NEHRU COLLEGE OF ENGINEERING AND RESEARCH CENTRE  
NEHRU SCHOOL OF MANAGEMENT  
NILA GARDENS, PAMPADY



Certificate Course: MS Office

Syllabus

MS Word

- Creating, editing, saving and printing text documents
- Font and paragraph formatting
- Simple character formatting
- Inserting tables, smart art, page breaks
- Using lists and styles

Ms. Excel

- Spreadsheet basics
- Creating, editing, saving and printing spreadsheets
- working with functions & formulas
- Modifying worksheets with color & autoformats
- Speeding data entry: Using Data Forms

Ms. Power Point

- Opening, viewing, creating, and printing slides
- Applying auto layouts
- Adding custom animation
- Using slide transitions

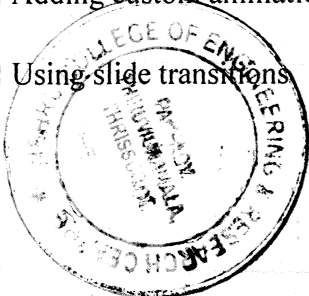

11

**PRINCIPAL**  
Nehru College of  
Engineering and Research Centre  
Pampady, Thiruvilwamala Thiruvananthapuram  
Pin: 680 597 Kerala

Nehru College of Engineering and research Centre

Department MBA

Program MS Office

Student list

SI No	Name of the student
1	ABDUL SALEEM.K
2	ABHINAV ANAND
3	ADHYA K S
4	ADITHYA RAJ M
5	AJITH THAMBI
6	AKHIL CHANDRAN
7	ALBINOSHIOUS TJ
8	AMRITHA.C.J
9	ANASWARA P R
10	ANISHA P RAVI
11	ANITHA S
12	ANJANA K
13	ATHIRA REJI
14	BOSCO.B.PALLAN
15	DEEPA.A
16	DEEPAK K DILEEP
17	DEEPTI SREENIVAS
18	DELMA JOHN
19	DEVIKA.P
20	DHANYAMOL.D
21	GEETHANJALI RADHAKRISHNAN
22	GEEVARGHESE.M.A
23	GOKUL A.G
24	GOVIND V P
25	GREESHMA P A
26	GREESHMA.VJ
27	IRFAN.M
28	IRIN RAJ
29	JAICY K J
30	JAISE K JOSEPH
31	JAYAN.K
32	JISHNU.M
33	KAILAS K
34	KAPIL K

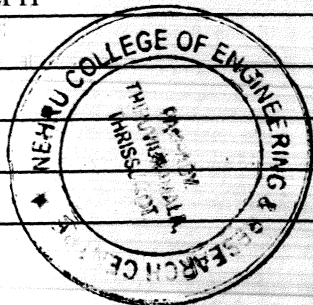

*M*  
*cd*

**PRINCIPAL**  
Nehru College of  
Engineering and Research Centre  
Pampady Thiruvilwamala Thiruvananthapuram  
Pin 680 501 Kerala

35	KARTHIK T
36	KAVITHA S KUMAR
37	KRISHNADAS.P
38	KRISHNA PRADEEP P V
39	KRISHNENDU AJI
40	KUNCHIMOIDEENSHA M.P
41	LIJIN JAMES
42	LIRIN BABY
43	MANJU ADAVAKKAT
44	MANOJ S
45	MAYA M
46	MIDHYA P M
47	MUBASHEER A
48	MUFEEDEHA.T.A
49	MUHAMED SHAJEEH KP
50	MUHAMMED SADIQUE V P
51	MUHAMMED SUHAIL V P
52	NEETHU.M.S
53	NICY DAVIS
54	NITHIN G K
55	NITHU.K.S
56	NITHYA MOHANKRISHNAN
57	NIVIN CHANDRAN
58	PRAMITHA K M
59	PRATHISH V P
60	PRIYA K
61	PRIYANKA K
62	RAJESH MK
63	RANJITH KUMAR M
64	RASMI S
65	RATHIN S
66	REJISH G
67	REKHA P KRISHNAN
68	RENJITHA BHASKARAN
69	RIJO JOHNY P
70	RIJO RAPHAEL C
71	RINI RAJ M R

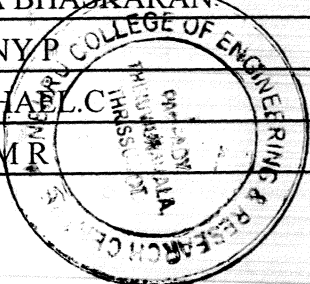

*[Handwritten Signature]*

**PRINCIPAL**  
Nehru College of  
Engineering and Research Cent.  
Pampady Thiruvilwamala Thiruvananthapuram  
Pin 680 597 Kerala

72	ROHINI A
73	ROHITH KRISHNAN
74	SABAREESH T
75	SAJITH K P
76	SANAL PN
77	SANEESH V M
78	SARATH S KUMAR
79	SARATH S MANAPPURATH
80	SARATH.V
81	SHAHABAS.N.S
82	SHAHANAS.K.I
83	SHAHANAS.V
84	SHALU V S
85	SHEMINA.E
86	SOUDHA K NAIR
87	SREEJA N
88	SREEJESH K S
89	SREELAKSHMI S
90	SRI LAKSHMI . K
91	SRUTHY K.V
92	STEENA P.J
93	SUDHA E V
94	SUKANYA .K
95	SUMI A
96	TEENU.T.WILSON
97	THASNEEM.M.A
98	THUSHARA A
99	VIJEEESHKUMAR. A.V
100	VINU SIMON
101	VISHNU AH
102	VISHNUDAS PK
103	VISHNU.KK
104	VISHNURAJ R
105	VISHNU RAVEENDRAN
106	VYSHAKH.V
107	ABHILASH K UNNI
108	ADARSH S KUMAR

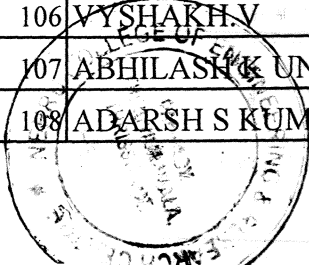

*cd*

**PRINCIPAL**  
Nehru College of  
Engineering and Research Centre  
Panipady Chiruvilwamala, Thrissur Dt  
Pin 680 597 Kerala

109	AISWARYA KRISHNADAS
110	AJAY KRISHNA S
111	AJITH A
112	AJMAL P P
113	AKHILA.K.M
114	AKSHAY R PILLAI
115	AMBILI.KC
116	ANEESHA RAJESH
117	ANITHA K SIVAKUMAR
118	ANJALI CHANDRAN
119	ANJALY C PRAKASH
120	ANOOP PS
121	ANU JOHN
122	ANUSREE.T.S
123	ARCHANA KR
124	ARJUN A
125	ARUN A G
126	ARUN V A
127	ASHIQ.V
128	ASWATHI.M
129	ASWATHI.PT
130	ASWIN T RAJU
131	BASIL WILSON
132	BLESSY FRANCIS
133	CHERIAN ABRAHAM
134	CHITHRA G
135	DEEPAK DAS T V
136	DEEPAK P S
137	DEEPTHI S
138	DIVYA S
139	FAHEEMA.P
140	GEO G KOOLA
141	HAREESH.H
142	HARITHA SARATH P
143	HASHIM T
144	JACQUELINE JOSE
145	JASIM M K

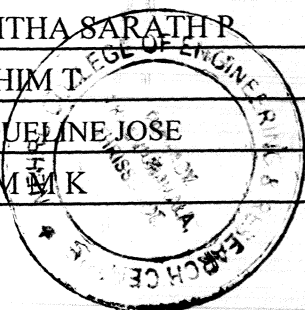

*Handwritten signature*

**PRINCIPAL**  
Nehru College of  
Engineering and Research Centre  
Pampady Thiruvilwamala Thiruvananthapuram Dt  
Pin 680 597 Kerala

146	JAYAKRISHNAN K
147	JEES GEORGE
148	JERESH JOSEPH
149	JOICE JOHNSON
150	JUSTIN M B
151	KARTHIK A
152	KRIPIL KRISHNA
153	KRISHNAPRIYA C
154	MARIYA SHOBY
155	MERIN KUNJUMON
156	MITHUN KRISHNA P
157	MOHAMMED ASHIQ V K
158	NEERAJA
159	NEETHU G
160	NEETHU KRISHNAN
161	N G PRADEEP
162	NILEENA MOHAN
163	NINYA C
164	NISHAD ABDUL AZEEZ T V
165	NISHAD B
166	NITISH.V.M
167	PARVATHY T
168	P R SREEKRISHNA
169	RAHUL GOPALAKRISHNAN NAIR
170	RAMDEV.K.S
171	RAMESH V
172	RAMSHAD K
173	REJI.P.J
174	RESHMA K
175	RESHMA.K
176	RESHMA MOHAN T
177	ROHINI.M.PANICKER
178	ROSANTO E A
179	ROSHNA RAHIM A
180	SACHIN SREEKUMAR
181	SHAFANA KHADEEJA
182	SHAIKTA S

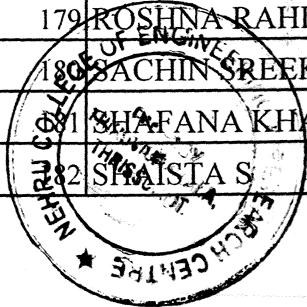

  
**PRINCIPAL**  
 Nehru College of  
 Engineering and Research Centre  
 Panipady Thiruvilwamala, Thiruvananthapuram Dt  
 Pin 686 557 Kerala

183	SHALOM PAUL
184	SHANIBA U K
185	SHEENA S
186	SHIBIN.K
187	SHRUTI MOHAN A
188	SIDHARTH V MENON
189	SIVANUNNI.P.S
190	SOORAJ.E

M

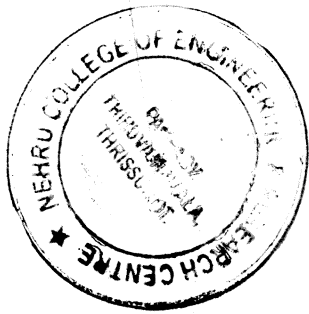

*[Handwritten signature]*

**PRINCIPAL**  
Nehru College of  
Engineering and Research Centre  
Panampady Thiruvilwamala, Thiruvananthapuram Dt  
Pin - 680 597 Kerala

**Nehru College of Engineering and Research centre**

Dept	MBA				
Program	Certificate course in MS Office				
Attendance					
Sl No	Name of the student	9th	16th	23rd	30th
1	ABDUL SALEEM.K	P	P	P	P
2	ABHINAV ANAND	P	P	P	P
3	ADHYA K S	P	P	P	P
4	ADITHYA RAJ M	P	P	P	P
5	AJITH THAMBI	P	P	P	P
6	AKHIL CHANDRAN	P	P	P	P
7	ALBINOSHIOUS TJ	P	P	P	P
8	AMRITHA.C.J	P	P	P	P
9	ANASWARA P R	P	P	P	P
10	ANISHA P RAVI	P	P	P	P
11	ANITHA.S	P	P	P	P
12	ANJANA K	P	P	P	P
13	ATHIRA REJI	P	P	P	P
14	BOSCO.B.PALLAN	P	P	P	P
15	DEEPA.A	P	P	P	P
16	DEEPAK K DILEEP	P	P	P	P
17	DEEPTI SREENIVAS	P	P	P	P
18	DELMA JOHN	P	P	P	P
19	DEVIKA.P	P	P	P	P
20	DHANYAMOL.D	P	P	P	P
21	GEETHANJALI RADHAKRISHNAN	P	P	P	P
22	GEEVARGHESE.M.A	P	P	P	P
23	GOKUL A.G	P	P	P	P
24	GOVIND V P	P	P	P	P
25	GREESHMA P A	P	P	P	P
26	GREESHMA.VJ	P	P	P	P
27	IRFAN.M	P	P	P	P
28	IRIN RAJ	P	P	P	P
29	JAICY K J	P	P	P	P
30	JAISE K JOSEPH	P	P	P	P
31	JAYAN.K	P	P	P	P
32	JISHNU.M	P	P	P	P
33	KAILAS K	P	P	P	P
34	KAPIL K	P	P	P	P
35	KARTHIK T	P	P	P	P
36	KAVITHA S KUMAR	P	P	P	P
37	KRISHNADAS.P	P	P	P	P
38	KRISHNA.PRADEEP P V	P	P	P	P
39	KRISHNENDU AJI	P	P	P	P
40	KUNCHIMOIDEENSHA M.P.	P	P	P	P
41	LIJIN JAMES	P	P	P	P

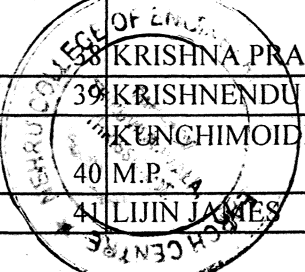

PRINCIPAL

Nehru College of  
Engineering and Research Centre  
Panampady, Thiruvilwamala, Thiruvananthapuram Dt

*[Handwritten signature]*

42	LIRIN BABY	P	P	P	/
43	MANJU ADAVAKKAT	P	P	P	/
44	MANOJ S	P	P	/	/
45	MAYA M	P	P	/	/
46	MIDHYA P M	P	P	/	/
47	MUBASHEER A	P	P	/	/
48	MUFEEHA.T.A	P	P	/	/
49	MUHAMED SHAJEEH KP	P	P	A	A
50	MUHAMMED SADIQUE V P	P	P	A	A
51	MUHAMMED SUHAIL V P	P	A	A	A
52	NEETHU.M.S	P	P	P	P
53	NICY DAVIS	P	P	A	P
54	NITHIN G K	P	P	P	P
55	NITHU.K.S	P	P	P	P
56	NITHYA MOHANKRISHNAN	P	P	A	P
57	NIVIN CHANDRAN	P	P	P	P
58	PRAMITHA K M	P	P	P	P
59	PRATHISH V P	P	P	P	P
60	PRIYA K	P	P	P	P
61	PRIYANKA K	P	P	P	P
62	RAJESH MK	P	P	P	P
63	RANJITH KUMAR M	P	P	P	P
64	RASMI S	P	P	P	P
65	RATHIN S	P	P	P	P
66	REJISH G	P	P	P	P
67	REKHA P KRISHNAN	P	P	P	A
68	RENJITHA BHASKARAN	P	P	P	P
69	RIJO JOHNY P	P	P	P	P
70	RIJO RAPHAEL.C	P	P	P	P
71	RINI RAJ M R	P	P	P	P
72	ROHINI A	P	P	P	P
73	ROHITH KRISHNAN	P	P	P	P
74	SABAREESH T	P	P	P	P
75	SAJITH K P	P	P	P	P
76	SANAL PN	P	P	P	P
77	SANEESH V M	P	P	P	P
78	SARATH S KUMAR	P	P	A	P
79	SARATH S MANAPPURATH	P	P	P	A
80	SARATH V	P	P	P	P
81	SHAHABAS.N.S	P	P	P	P

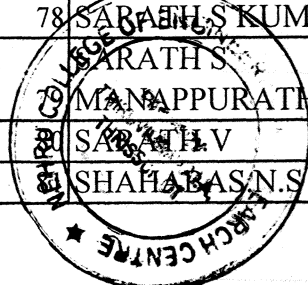

PRINCIPAL  
Nehru College of  
Engineering and Research Centre  
Panipady Thiruvilwamala, Thiruvananthapuram

Handwritten signature

82	SHAHANAS.K.I	P	X	P	P
83	SHAHANAS.V	P	X	P	P
84	SHALU V S	P	P	P	P
85	SHEMINA.E	P	P	P	P
86	SODHA K NAIR	P	P	P	P
87	SREEJA N	P	P	P	P
88	SREEJESH K S	P	P	P	P
89	SREELAKSHMI S	P	P	P	P
90	SRI LAKSHMI . K	P	P	P	P
91	SRUTHY K.V	P	P	P	P
92	STEENA P.J	P	P	P	P
93	SUDHA E V	P	P	P	P
94	SUKANYA .K	P	P	P	P
95	SUMI A	P	P	P	P
96	TEENU.T.WILSON	P	P	P	P
97	THASNEEM.M.A	P	P	P	P
98	THUSHARA A	P	P	P	P
99	VIJEESHKUMAR. A.V	P	P	P	P
100	VINU SIMON	P	P	P	P
101	VISHNU AH	P	P	P	P
102	VISHNUDAS PK	P	P	P	P
103	VISHNU.KK	P	P	P	P
104	VISHNURAJ R	P	P	P	P
105	VISHNU RAVEENDRAN	P	P	P	P
106	VYSHAKH.V	P	P	P	P
107	ABHILASH K UNNI	P	P	P	P
108	ADARSH S KUMAR	P	P	P	P
109	AISWARYA KRISHNADAS	P	P	P	P
110	AJAY KRISHNA S	P	P	P	P
111	AJITH A	P	P	P	P
112	AJMAL P P	P	P	P	P
113	AKHILA.K.M	P	P	P	P
114	AKSHAY R PILLAI	P	P	P	P
115	AMBILI.KC	P	P	P	P
116	ANEESHA RAJESH	P	P	P	P
117	ANITHA K SIVAKUMAR	P	P	P	P
118	ANJALI CHANDRAN	P	P	P	P
119	ANJALY C PRAKASH	P	P	P	P
120	ANOOP PS	P	P	P	P
121	ANU JOHN	P	P	P	P
122	ANUSREE.T.S	P	P	P	P
123	ARJUNA KR	P	P	P	P
124	ARJUN A	P	P	P	P
125	ARJUN A G	P	P	P	P

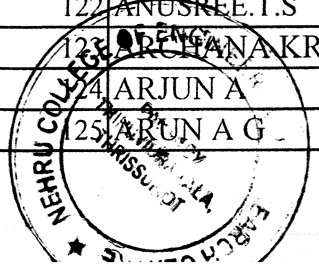

PRINCIPAL  
Nehru College of  
Engineering and Research Center  
Panpady Thiruvilwamala, Thiruvananthapuram

*[Handwritten signature]*

126	ARUN V A	P	P	P	P
127	ASHIQ.V	P	P	P	P
128	ASWATHI.M	P	P	P	P
129	ASWATHI.PT	P	P	P	P
130	ASWIN T RAJU	P	P	P	P
131	BASIL WILSON	P	P	P	P
132	BLESSY FRANCIS	P	P	P	P
133	CHERIAN ABRAHAM	P	P	P	P
134	CHITHRA G	P	P	P	P
135	DEEPAK DAS T V	P	P	P	P
136	DEEPAK P S	P	P	P	P
137	DEEPTHI S	P	P	P	P
138	DIVYA S	P	P	P	P
139	FAHEEMA.P	P	P	P	P
140	GEO G KOOLA	P	P	P	P
141	HAREESH.H	P	P	P	P
142	HARITHA SARATH P	P	P	P	P
143	HASHIM T	P	P	P	P
144	JACQUELINE JOSE	P	P	P	P
145	JASIM M K	P	P	P	P
146	JAYAKRISHNAN K	P	P	P	P
147	JEES GEORGE	P	P	P	P
148	JERESH JOSEPH	P	P	P	P
149	JOICE JOHNSON	P	P	P	P
150	JUSTIN M B	P	P	P	P
151	KARTHIK A	P	P	P	P
152	KRIPIL KRISHNA	P	P	P	P
153	KRISHNAPRIYA C	P	P	P	P
154	MARIYA SHOBY	P	P	P	P
155	MERIN KUNJUMON	P	P	P	P
156	MITHUN KRISHNA P	P	P	P	P
157	MOHAMMED ASHIQ V K	P	P	P	P
158	NEERAJA	P	P	P	P
159	NEETHU G	P	P	P	P
160	NEETHU KRISHNAN	P	P	P	P
161	N G PRADEEP	P	P	P	P
162	NILEENA MOHAN	P	P	P	P
163	NINYA C	P	P	P	P
164	NISHAD ABDUL AZEEZ T V	P	P	P	P
165	NISHAD B	P	P	P	P
166	NISHITH.V.M	P	P	P	P
167	PARVATHY T	P	P	P	P
168	P R SREEKRISHNA	P	P	P	P

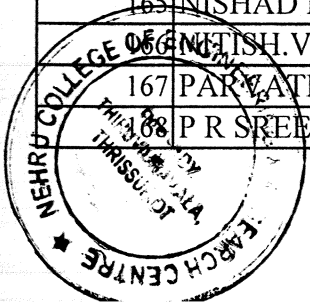

PRINCIPAL  
Nehru College of  
Engineering and Research Centre  
Panipady Thiruvilwamala Thiruvananthapuram Dt  
Pin 680 597 Kerala

169	RAHUL GOPALAKRISHNAN NAIR	P	A	A	A
170	RAMDEV.K.S	P	P	P	P
171	RAMESH V	P	P	P	P
172	RAMSHAD K	P	P	P	P
173	REJI.P.J	P	P	P	P
174	RESHMA K	P	P	P	P
175	RESHMA.K	P	P	P	P
176	RESHMA MOHAN T	P	P	P	P
177	ROHINI.M.PANICKER	P	P	P	P
178	ROSANTO E A	P	P	P	P
179	ROSHNA RAHIM A	P	P	P	P
180	SACHIN SREEKUMAR	P	P	P	P
181	SHAFANA KHADEEJA	P	P	P	P
182	SHAISTA S	P	P	P	P
183	SHALOM PAUL	P	P	P	P
184	SHANIBA U K	P	P	P	P
185	SHEENA S	P	P	P	P
186	SHIBIN.K	P	P	P	P
187	SHRUTI MOHAN A	P	P	P	P
188	SIDHARTH V MENON	P	P	P	P
189	SIVANUNNI.P.S	P	P	P	P
190	SOORAJ.E	P	P	P	P

11

*Che*

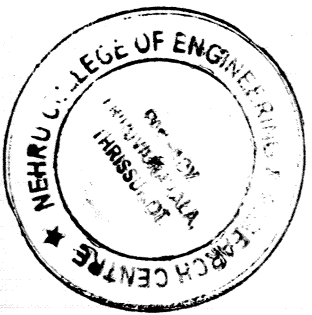

**PRINCIPAL**  
Nehru College of  
Engineering and Research Centre  
Pampady Thiruvilwamala, Thiruvananthapuram  
Pin 680 597 Kerala



NEHRU COLLEGE OF ENGINEERING AND RESEARCH CENTRE  
NEHRU SCHOOL OF MANAGEMENT  
NILA GARDENS, PAMPADY



Nehru School of Management

MS Office Question Paper

Section-A(10 marks)

- Files newly created in MS-Office are stored in the \_\_\_\_\_ until we use File, Save command to store on a disk  
a) RAM b) Clipboard c) Temporary files d) Cache memory.
- What button do you click to quickly down application?  
a) The control button b) The minimize button c) The close button d) Theshut down button.
- We can copy selected text by holding \_\_\_\_\_ key and dragging the text to the location.  
a) Alt b) Shift c) Ctrl d) Tab.
- We must choose \_\_\_\_\_ option to allow to wrap around the picture.  
a) Contour wrap b) Wrapping c) Text Replacement d) Position.

Fill in the blanks:

(10 Marks)

- The first row of the window is called the \_\_\_\_\_
- A \_\_\_\_\_ is a device that is used to manipulate objects in window.
- The \_\_\_\_\_ window contains information about your computer drives.
- A \_\_\_\_\_ is a collection of buttons that represents commands.
- A group of computers connected together for the purpose of sharing resources is called \_\_\_\_\_
- GUI = \_\_\_\_\_

Say True or False

(10 Marks)

- Pressing Ctrl+Alt+Del to restart the system.
- Clipboard is a tool provided by windows that holds any cut or copied text temporarily in memory.
- Scrollbars are used to display contents.
- Windows explorer enables you to see all the files and folders on your computer.
- My Computer does not provide a simpler view of the folders on your computer.

Multiple Choice questions

(20 Marks)

1) The spelling and grammar tool

A. Indicates grammatical errors

B. Corrects spelling errors as you type

C. Identifies words with capitalization problems

D. All of above

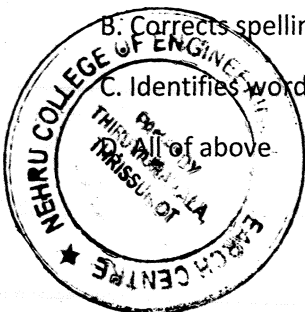

  
**PRINCIPAL**  
Nehru College of  
Engineering and Research Centre  
Pampady Thiruvilwamala, Thiruvilwamala, Thiruvilwamala, Thiruvilwamala  
Pin 680 597 Kerala



NEHRU COLLEGE OF ENGINEERING AND RESEARCH CENTRE  
NEHRU SCHOOL OF MANAGEMENT  
NILA GARDENS, PAMPADY



2) You can replace the text

- A. Ctrl+H
- B. Ctrl+R
- C. Replace from Edit menu
- D. Both a & b

3) The insertion point

- A. Provides features for changing margins, tabs, and indentations
- B. Indicated the location where text line when necessary
- C. Is located under the standard toolbar and has shortcut buttons
- D. Is located under the standard toolbar and shortcut buttons

4) When you want to view different parts of a document without moving the insertion point.

- A. Use the previous page or next page buttons
- B. Use the keyboard
- C. Use the vertical and horizontal scroll bars
- D. Use the zoom button

5) Hyperlinks can be created between a Word document and

- A. Another word document
- B. A web page on the www
- C. A web page on a company Internet
- D. All of above

6) You can insert the clip art from

- A. From Insert choose Pictures then Clip Art
- B. Choose Clip Art icon from Drawing toolbar
- C. All of above
- D. None of above

7) Which of the following cannot be done with document version?

- A. Modifying a version
- B. Deleting a version

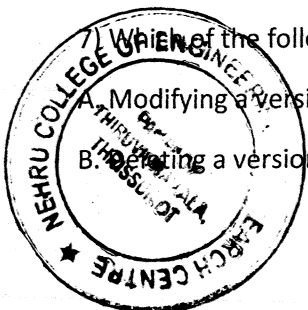

**PRINCIPAL**  
Nehru College of  
Engineering and Research Centre  
Pampady Thiruvilwamala, Thrissur Dt  
Pin - 680 597 Kerala



NEHRU COLLEGE OF ENGINEERING AND RESEARCH CENTRE  
NEHRU SCHOOL OF MANAGEMENT  
NILA GARDENS, PAMPADY



C. Opening a version

D. None of above

8) When you drag selected text you can

A. Delete text

B. Link text

C. Copy text

D. Move text

9) You can search in a word document for

A. Formatting

B. Special characters

C. Phrases

D. All of the above

10) You can add a date to a document by

A. Inserting a text date

B. Inserting a date field that will update automatically

C. Typing the date manually

D. All of the above

11) Right clicking on something in word

A. Delete the object

B. Nothing the right mouse button is there for left handed people

C. Opens the short-cut list

D. Insert the picture

12) We can create the new shortcut key from

A. Options from Tools menu

B. Customize from Tools menu

C. Properties from File menu

D. Options from Toolbars menu

13) The autocorrect tool

A. Provides statistics about your document

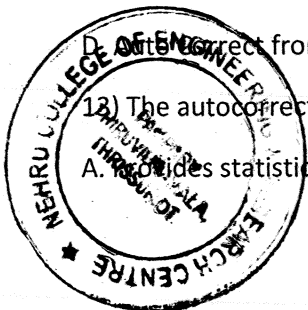

**PRINCIPAL**  
Nehru College of  
Engineering and Research Centre  
Pampady Thiruvilwamala, Thiruvananthapuram Dt  
Pin - 680 597 Kerala



NEHRU COLLEGE OF ENGINEERING AND RESEARCH CENTRE  
NEHRU SCHOOL OF MANAGEMENT  
NILA GARDENS, PAMPADY



- B. Displays words with the same or similar meaning
- C. Checks the grammar in the document
- D. Checks for misspelled words as you type and correct them as defined
- 14) Which key or key combination will move the insertion point to the bottom of your document?
- A. Ctrl+End
- B. PageDown
- C. Ctrl+Home
- D. End
- 15) To display hyperlink fields in a Word document, you can press the
- A. Ctrl+Shift+F9 key
- B. Shift + F9
- C. Ctrl+Alt key
- D. None of above
- 16) When you have completely finished working with a document you should
- A. Close it
- B. Save it
- C. Type it
- D. Edit it
- 17) To cut or copy text you must first
- A. Click the remove/duplicate button
- B. First highlight the text and click the Copy or Cut command from edit menu
- C. Click on File menu
- D. None of above
- 18) How many items can you copy to the Office Clipboard
- A. 24
- B. 20

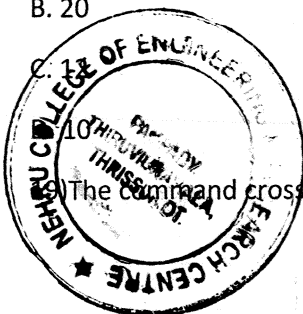

The command cross reference is available in

**PRINCIPAL**  
Nehru College of  
Engineering and Research Centre  
Pampady, Thiruvilwamala, Thirissur Dist  
Pin 680 597 Kerala



NEHRU COLLEGE OF ENGINEERING AND RESEARCH CENTRE  
NEHRU SCHOOL OF MANAGEMENT  
NILA GARDENS, PAMPADY



- A. View menu
- B. Format menu
- C. Insert menu
- D. Tools menu

20) We can send the word documents to

- A. Microsoft PowerPoint
- B. Microsoft Excel
- C. Microsoft Access
- D. All of above

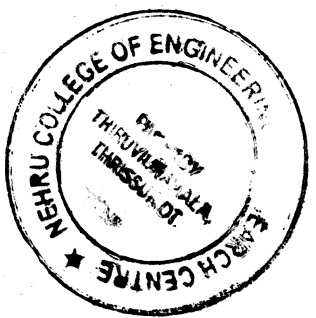

*M*

*[Handwritten Signature]*

**PRINCIPAL**  
Nehru College of  
Engineering and Research Centre  
Pampady, Thiruvilwamala, Thiruvananthapuram  
Pin 680 597 Kerala



NEHRU COLLEGE OF ENGINEERING AND RESEARCH CENTRE  
NEHRU SCHOOL OF MANAGEMENT  
NILA GARDENS, PAMPADY



**Nehru School of Management**

**MS Office Answer Key**

**Section-A(10 marks)**

1. c

2. b

3. b

4. b

Fill in the blanks:

1. Title bar
2. mouse
3. network
4. keyboard
5. Network
6. Graphical user interface

Say True or False

1. False
2. True
3. False
4. True
5. False.

Multiple Choice questions

(20 Marks)

1) D

2) D

3) A

4) B

5) D

6) C

7) A

8) D

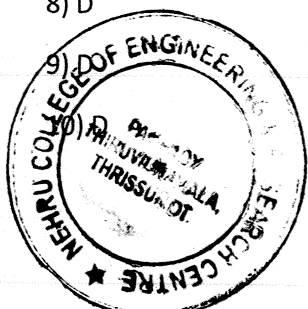

**-PRINCIPAL**  
Nehru College of  
Engineering and Research Centre  
Pampady Thiruvilwamala, Thiruvananthapuram  
Dist. 686 597 Kerala



NEHRU COLLEGE OF ENGINEERING AND RESEARCH CENTRE  
NEHRU SCHOOL OF MANAGEMENT  
NILA GARDENS, PAMPADY



- 11) C
- 12) A
- 13) D
- 14) B
- 15) D
- 16) B
- 17) B
- 18) A
- 19) C
- 20) D

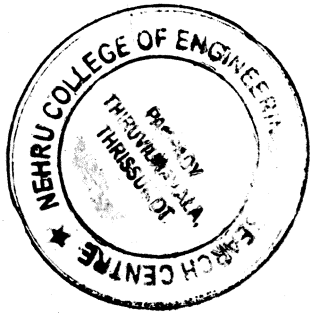

M

A handwritten signature in black ink is located in the bottom right area of the page.

**PRINCIPAL**  
Nehru College of  
Engineering and Research Centre  
Pampady Thiruvilwamala, Thirissur Dt  
Pin 680 597 Kerala



NEHRU COLLEGE OF ENGINEERING AND RESEARCH CENTRE  
NEHRU SCHOOL OF MANAGEMENT  
NILA GARDENS, PAMPADY



Certificate Course

Subject Name: *Ms. office*

Student Name: *Ajith. T*

- 1 A
- 2 C
- 3 B
- 4 A
- 5 Title bar
- 6 Mouse
- 7 Network
- 8 Keyboard
- 9 Network
- 10 Graphical interface
- 11 True
- 12 True
- 13 False
- 14 True
- 15 True

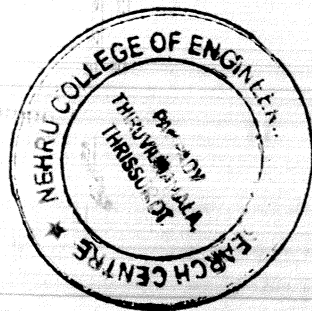

*[Signature]*

**PRINCIPAL**  
Nehru College of  
Engineering and Research Centre  
Pampady Thiruvilwamala, Thrissur Dt  
Pin. 680 597 Kerala

16 B

17 A

18 C

19 B

20 C

21 C

22 B

23 A

24 A

25 A

26 B

27 C

28 B

29 C

30 B

31 A

32 B

33 B

34 C

35 A

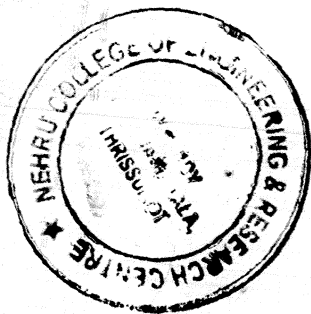

**PRINCIPAL**

Nehru College of

Engineering and Research Centre

Panpady, Thiruvilwamala, Thiruvananthapuram

Pin 680 597 Kerala



NEHRU COLLEGE OF ENGINEERING AND RESEARCH CENTRE  
NEHRU SCHOOL OF MANAGEMENT  
NILA GARDENS, PAMPADY



Certificate Course

Subject Name: *MS office*

Student Name: *Abinav*

- 1 A
- 2 B-
- 3 c
- 4 B
- 5 Title bar
- 6 Mouse
- 7 Network
- 8 keyboard
- 9 Network
- 10 Graphical user interface
- 11 True
- 12 false
- 13 false
- 14 true
- 15 true

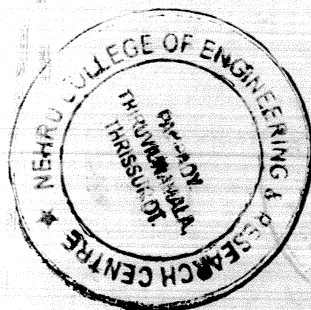

PRINCIPAL  
Nehru College of  
Engineering and Research Centre  
Pampady Thiruvilwamala, Thrissur Dist.  
Pin - 680 597 Kerala

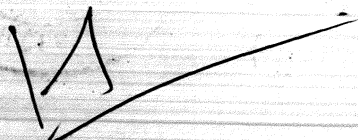

- 16 A
- 17 A
- 18 B
- 19 B
- 20 C
- 21 C
- 22 A
- 23 B
- 24 C
- 25 C
- 26 C
- 27 B
- 28 B
- 29 A
- 30 A
- 31 C
- 32 C
- 33 B
- 34 B
- 35 A

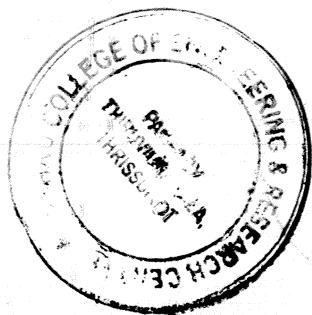

*Ch*

**PRINCIPAL**  
Nehru College of  
Engineering and Research Centre  
Pamipady Thiruvilwamala Thiruvananthapuram Dt  
Pin 680 597 Kerala



NEHRU COLLEGE OF ENGINEERING AND RESEARCH CENTRE  
NEHRU SCHOOL OF MANAGEMENT  
NILA GARDENS, PAMPADY



Certificate Course

Subject Name: MS office

Student Name: Anithas

A

1. c

2. b

3. b

4. b

B

1. Title bar

2. Mouse

3. Network

4. key board

5. Network

6.

C

1 True

2 True

false

True

false

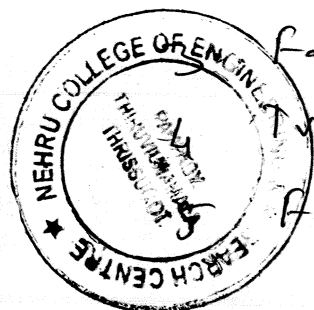

M

D

1 D

2 D

3 M

4 B

5 D

6 C

7 A

8 D

9 D

10 D

11 A

12 B

13 C

14 A

15 D

16 A

17 B

18 A

19 A

*(Signature)*

PRINCIPAL

Nehru College of  
Engineering and Research Centre  
Pampady Thiruvilwamala Thiruvananthapuram  
Pin 680 597 Kerala

20 A

Nehru College of Engineering and research Centre

Department MBA

Program MS Office

Mark list		Marks
Sl No	Name of the student	
1	ABDUL SALEEM.K	45
2	ABHINAV ANAND	44
3	ADHYA K S	43
4	ADITHYA RAJ M	42
5	AJITH THAMBI	35
6	AKHIL CHANDRAN	37
7	ALBINOSHIOUS TJ	34
8	AMRITHA.C.J	35
9	ANASWARA P R	43
10	ANISHA P RAVI	43
11	ANITHA S	42
12	ANJANA K	36
13	ATHIRA REJI	43
14	BOSCO.B.PALLAN	41
15	DEEPA.A	44
16	DEEPAK K DILEEP	34
17	DEEPTI SREENIVAS	35
18	DELMA JOHN	36
19	DEVIKA.P	37
20	DHANYAMOL.D	45
21	GEETHANJALI RADHAKRISHNAN	44
22	GEEVARGHESE.M.A	43
23	GOKUL A.G	42
24	GOVIND V P	35
25	GREESHMA P A	37
26	GREESHMA.VJ	34
27	IRFAN.M	35
28	IRIN RAJ	43
29	JAICY K J	43
30	JAISE K JOSEPH	42
31	JAYAN K	36
32	JISHNUM	43
33	KAILAS.K	41
34	KAPIL K	44

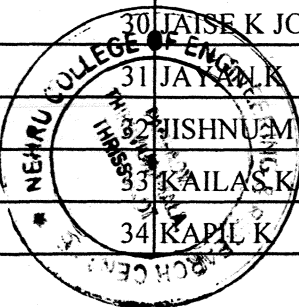

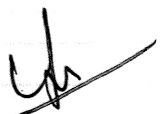
  
**PRINCIPAL**  
 Nehru College of  
 Engineering and Research Centre  
 Panampady Thiruvilwamala Thirissur Dt  
 Pin 680 597 Kerala



35	KARTHIK T	34
36	KAVITHA S KUMAR	35
37	KRISHNADAS.P	36
38	KRISHNA PRADEEP P V	37
39	KRISHNENDU AJI	45
40	KUNCHIMOIDEENSHA M.P	44
41	LIJIN JAMES	43
42	LIRIN BABY	42
43	MANJU ADAVAKKAT	35
44	MANOJ S	37
45	MAYA M	34
46	MIDHYA P M	35
47	MUBASHEER A	43
48	MUFEEDHA.T.A	43
49	MUHAMED SHAJEEH KP	42
50	MUHAMMED SADIQUE V P	36
51	MUHAMMED SUHAİL V P	43
52	NEETHU.M.S	41
53	NICY DAVIS	44
54	NITHIN G K	34
55	NITHU.K.S	35
56	NITHYA MOHANKRISHNAN	36
57	NIVIN CHANDRAN	37
58	PRAMITHA K M	45
59	PRATHISH V P	44
60	PRIYA K	43
61	PRIYANKA K	42
62	RAJESH MK	35
63	RANJITH KUMAR M	37
64	RASMI S	34
65	RATHIN S	35
66	REJISH G	43
67	REKHA P KRISHNAN	43
68	RENJITHA BHASKARAN	42
69	RIMO JOHNY P	36
70	RIMO RAPHAEL.C	43
71	RINI RAJ M R	41

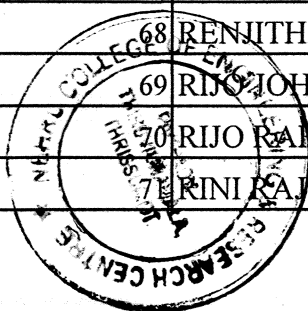

*[Handwritten Signature]*

PRINCIPAL  
Nehru College of  
Engineering and Research Cent.  
Pampady, Thiruvilwamala, Thiruvananthapuram  
Pin 680 597 Kerala

72	ROHINI A	44
73	ROHITH KRISHNAN	34
74	SABAREESH T	35
75	SAJITH K P	36
76	SANAL PN	37
77	SANEESH V M	45
78	SARATH S KUMAR	44
79	SARATH S MANAPPURATH	43
80	SARATH.V	42
81	SHAHABAS.N.S	35
82	SHAHANAS.K.I	37
83	SHAHANAS.V	34
84	SHALU V S	35
85	SHEMINA.E	43
86	SOUDHA K NAIR	43
87	SREEJA N	42
88	SREEJESH K S	36
89	SREELAKSHMI S	43
90	SRI LAKSHMI . K	41
91	SRUTHY K.V	44
92	STEENA P.J	34
93	SUDHA E V	35
94	SUKANYA .K	36
95	SUMI A	37
96	TEENU.T.WILSON	45
97	THASNEEM.M.A	44
98	THUSHARA A	43
99	VIJEESHKUMAR. A.V	42
100	VINU SIMON	35
101	VISHNU AH	37
102	VISHNUDAS PK	34
103	VISHNU.KK	35
104	VISHNURAJ R	43
105	VISHNU RAVEENDRAN	43
106	VYSK.K.H.V	42
107	ABHILASH K UNNI	36
108	ADARSH S KUMAR	43

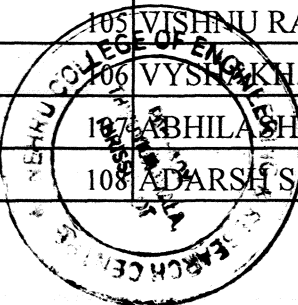

PRINCIPAL  
Nehru College of  
Engineering and Research Centre  
Pampady Thiruvilwamala, Thiruvananthapuram  
Pin 680 597 Kerala

109	AISWARYA KRISHNADAS	41
110	AJAY KRISHNA S	44
111	AJITH A	34
112	AJMAL P P	35
113	AKHILA.K.M	36
114	AKSHAY R PILLAI	37
115	AMBILI.KC	45
116	ANEESHA RAJESH	44
117	ANITHA K SIVAKUMAR	43
118	ANJALI CHANDRAN	42
119	ANJALY C PRAKASH	35
120	ANOOP PS	37
121	ANU JOHN	34
122	ANUSREE.T.S	35
123	ARCHANA KR	43
124	ARJUN A	43
125	ARUN A G	42
126	ARUN V A	36
127	ASHIQ.V	43
128	ASWATHI.M	41
129	ASWATHI.PT	44
130	ASWIN T RAJU	34
131	BASIL WILSON	35
132	BLESSY FRANCIS	36
133	CHERIAN ABRAHAM	37
134	CHITHRA G	45
135	DEEPAK DAS T V	44
136	DEEPAK P S	43
137	DEEPTHI S	42
138	DIVYA S	35
139	FAHEEMA.P	37
140	GEO G KOOLA	34
141	HAREESH.H	35
142	HARITHA SARATH P	43
143	HASHIM T	43
144	JACQUELINE JOSE	42
145	JASIM M K	36

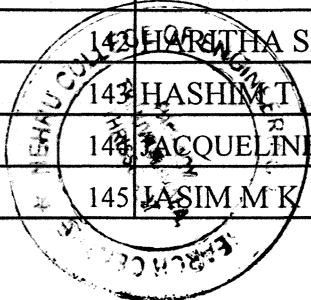

*Handwritten signature*

PRINCIPAL  
Nehru College of  
Engineering and Research Centre  
Pampady Thiruvilwamala, Thiruvananthapuram Dt  
Pin 680 597 Kerala

146	JAYAKRISHNAN K	43
147	JEES GEORGE	41
148	JERESH JOSEPH	44
149	JOICE JOHNSON	34
150	JUSTIN M B	35
151	KARTHIK A	36
152	KRIPIL KRISHNA	37
153	KRISHNAPRIYA C	45
154	MARIYA SHOBY	44
155	MERIN KUNJUMON	43
156	MITHUN KRISHNA P	42
157	MOHAMMED ASHIQ V K	35
158	NEERAJA	37
159	NEETHU G	34
160	NEETHU KRISHNAN	35
161	N G PRADEEP	43
162	NILEENA MOHAN	43
163	NINYA C	42
164	NISHAD ABDUL AZEEZ T V	36
165	NISHAD B	43
166	NITISH.V.M	41
167	PARVATHY T	44
168	P R SREEKRISHNA	34
169	RAHUL GOPALAKRISHNAN NAIR	35
170	RAMDEV.K.S	36
171	RAMESH V	37
172	RAMSHAD K	45
173	REJI.P.J	44
174	RESHMA K	43
175	RESHMA.K	42
176	RESHMA MOHAN T	35
177	ROHINI.M.PANICKER	37
178	ROSANTO E A	34
179	ROSHNA RAHIM A	35
180	SACHIN SREEKUMAR	43
181	SHAFANA KHADEEJA	43
182	SHAISTACS	42

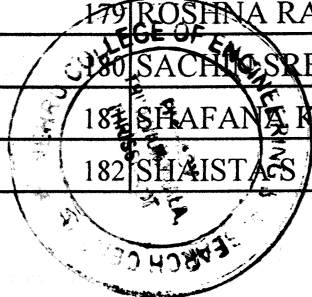

*Handwritten signature*

PRINCIPAL  
Nehru College of  
Engineering and Research Centre  
Parappady Thiruvilwamala, Thirissur District,  
Kerala  
Pin 680 597

183	SHALOM PAUL	36
184	SHANIBA U K	43
185	SHEENA S	41
186	SHIBIN.K	44
187	SHRUTI MOHAN A	34
188	SIDHARTH V MENON	35
189	SIVANUNNI.P.S	36
190	SOORAJ.E	37

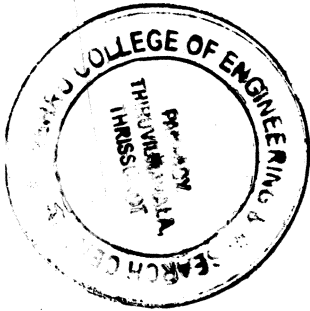

M

PRINCIPAL  
Nehru College of  
Engineering and Research Centre  
Pampady Thiruvilwamala, Thirissur District  
Pin 680 597 Kerala

Nehru College of Engineering and Research Centre  
Management Department

**Cordially invite all Management students to a certificate  
course on  
"MS Office"  
By  
Dr. Sudheer Marar**

**Program Coordinator: Dr. KVS Raj**

14



**PRINCIPAL**  
Nehru College of  
Engineering and Research Centre  
Panipady, Thiruvilwamala, Thrissur Dt  
Pin 680 597 Kerala

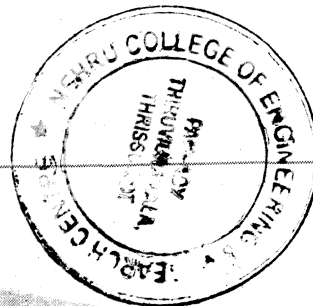

**Dates: 9<sup>th</sup>, 16<sup>th</sup>, 23<sup>th</sup> and 30<sup>th</sup> January 2016**

## **Program Chart**

### **Day 1**

**9.00 AM Director MBA address**

**9.15 AM Introduction of Resource Person by Coordinator**

**9.30 to 11.00 Session 1**

**11.15 to 12.30 Session 2**

**1.00 to 2.00 Session 3**

**2.15 to 4.00 Session 4**

### **Day 2,3 and 4**

**9.00 to 11.00 Session**

**11.15 to 12.30 Session**

**Lunch**

**1.00 to 2.30 Session**

**2.45 to 4.00 Session**

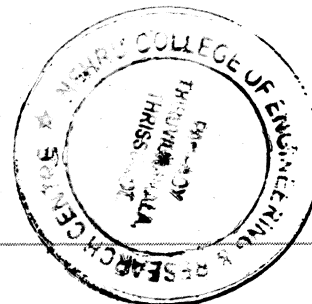

A handwritten signature in black ink, appearing to be "Ch".

**PRINCIPAL**  
Nehru College of  
Engineering and Research Centre  
Pampady Thiruvilwamala, Thiruvananthapuram  
Pin 680 597, Kerala



# NEHRU COLLEGE OF ENGINEERING & RESEARCH CENTRE



Accredited by NAAC  
An ISO 9001-2015 certified Institution, Approved by AICTE, New Delhi  
Affiliated to APJ Abdul Kalam Technological University  
PAMPADY, THIRUVILWAMALA, THRISSUR (Dist)

# Certificate

*This certificate is proudly presented to*

*Mr./Ms.....SOORAJ... E..... of*

*Nehru College of Engineering and Research Centre,*

*for successfully completing the course*

*in....M.S.office....*

*and for passing the final exam.*

PROGRAM CO-ORDINATOR  
NSM

Director  
NSM

PRINCIPAL  
NCERC

PRINCIPAL  
Nehru College of  
Engineering and Research Centre  
Pampady, Thiruvilwamala, Thrissur  
Pin - 680 507 Kerala

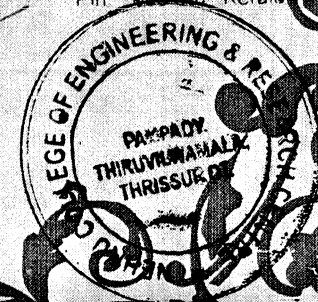



# NEHRU COLLEGE OF ENGINEERING & RESEARCH CENTRE



Accredited by NAAC  
An ISO 9001-2015 certified Institution, Approved by AICTE, New Delhi  
Affiliated to APJ Abdul Kalam Technological University  
PAMPADY, THIRUVILWAMALA, THRISSUR (Dist)

# Certificate

*This certificate is proudly presented to*

*Mr./Ms....ROJANTO..... of*

*Nehru College of Engineering and Research Centre,*

*for successfully completing the course*

*in...MS...office....*

*and for passing the final exam.*

  
PROGRAM CO-ORDINATOR  
NSM

  
Director  
NSM

  
PRINCIPAL  
NCERC

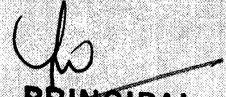
  
PRINCIPAL  
Nehru College of  
Engineering and Research  
Pampady, Thiruvilwamala, Th

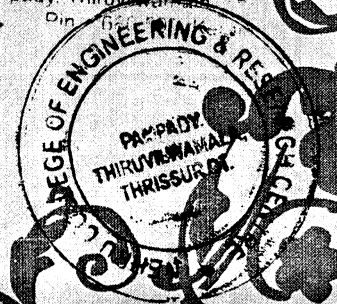



**NEHRU COLLEGE OF ENGINEERING AND RESEARCH CENTRE**  
**(NAAC Accredited)**

(Approved by AICTE, Affiliated to APJ Abdul Kalam Technological University, Kerala)



# **Electronics and Communication Engineering**



# NEHRU COLLEGE OF ENGINEERING & RESEARCH CENTRE



Accredited by NAAC  
An ISO 9001-2015 certified Institution, Approved by AICTE, New Delhi  
Affiliated to APJ Abdul Kalam Technological University  
PAMPADY, THIRUVILWAMALA, THRISSUR (Dist)

# Certificate

*This certificate is proudly presented to*

*Mr./Ms..... R. E. J. P. S. .... of*

*Nehru College of Engineering and Research Centre,*

*for successfully completing the course*

*in... M.S. o/b... ..*

*and for passing the final exam.*

PROGRAM CO-ORDINATOR  
NSM

Director  
NSM

PRINCIPAL  
NCERC

*[Signature]*  
PRINCIPAL  
Nehru College of  
Engineering and Research Centre  
Pampady Thiruvilwamala, Thri  
Dist. 686 507 Kerala

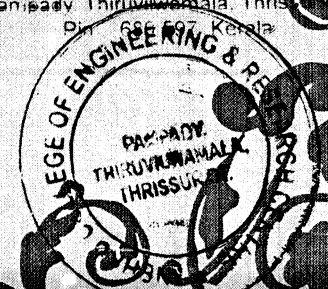



**NEHRU COLLEGE OF ENGINEERING AND RESEARCH CENTRE  
(NAAC Accredited)**

(Approved by AICTE, Affiliated to APJ Abdul Kalam Technological University,  
Kerala)



**ELECTRONICS AND COMMUNICATION DEPARTMENT**

**NOTICE**

**30.07.2015**

Department has decided to conduct a certificate course on "HIGH SPEED DIGITAL SYSTEM DESIGN " on second and fourth Saturdays during this academic year 2014-15. The duration of the course will be for a period of 34 hours. The objective of the course is to impart knowledge on signal propagation analysis. This course will act as a key for enhancing know how of students on area of wave propagation and principles

The 2013-17 batch admission(UG) of ECE department are eligible for this course. All concerned students should attend the entire course without fail. Attendance is compulsory.

Copy:

- 1.Department Notice Board
- 2.Staff advisors(For Information to students)
- 3.Office file



**HoD  
PRINCIPAL**

Nehru College of  
Engineering and Research Centre  
Pampady, Thiruvilwamala, Thirissur Dt.  
Pin - 680 597, Kerala



NEHRU COLLEGE OF ENGINEERING AND RESEARCH CENTRE  
(NAAC Accredited)



(Approved by AICTE, Affiliated to APJ Abdul Kalam Technological University, Kerala)

FROM,

P RAJKUMAR

ASSOCIATE PROFESSOR,

ECE DEPARTMENT, NCERC, PAMPADY.

TO,

THE PRINCIPAL,

NCERC, PAMPADY.

Through HOD

Respected Sir/Madam,

SUBJECT:-Request for conducting a certificate Course Reg.

Department of Electronics & communication Engineering, NCERC, is planning to conduct an Add-On Course on "HIGH SPEED DIGITAL SYSTEM DESIGN" from 4-8-15. The course is scheduled as a 30 hour program. The main objective of this course is to provide students an understanding of digital electronics. Kindly request you to grant the permission for conducting the sessions.

All UG/ Students of ECE Dept,are eligible for this course.

Thanking you for your consideration. I look forward to your response soon.

Yours sincerely,

Place:

*14/8/15 Pampady*

Date:

*14/8/15*

*[Signature]*  
HOD

*[Signature]*

*permitted*



PRINCIPAL  
Nehru College of  
Engineering and Research Centre  
Pampady Thiruvilwamala Thiruvananthapuram Dt  
Pin 680 597 Kerala



NEHRU COLLEGE OF ENGINEERING AND RESEARCH CENTRE  
(NAAC Accredited)

(Approved by AICTE, Affiliated to APJ Abdul Kalam Technological University, Kerala)



NEHRU COLLEGE OF ENGINEERING AND RESEARCH CENTRE  
(ACCREDITED BY NAAC)  
PAMPADY, THIRUVILWAMALA, THRISSUR DIST.

MINUTES OF DEPARTMENT ADVISORY COMMITTEE MEETING HELD ON 01/08/2015

A meeting of the Department Advisory Committee (DAC) was held on 24<sup>th</sup> July 2015 at 1:00 PM in the chamber of HoD, ECE department.

The following members were present:

1. Dr S Rajkumar-HoD, ECE Dept.
2. Mr. Raghu M C-Assistant Professor, ECE Dept.
3. Mr. Vishnu Prabha N Kaimal-Assistant Professor, ECE Dept.
4. Mrs. Sajitha A S-Assistant Professor, ECE Dept.
5. Mrs. Lisa C-Assistant Professor, ECE Dept.

The following decisions were taken:

1. It was decided to conduct a certificate course on "HIGH SPEED DIGITAL SYSTEM DESIGN" during the second and fourth Saturdays of the academic year 2015-16 for a period of 30 hours.
2. The course will update the technical knowledge of students in the latest developments related to the field of electromagnetic theory principles
3. It was decided to provide the course for all UG students.
4. Also, it was decided to ensure compulsory attendance and staff advisors should monitor the same.

The meeting came to an end at 1:45 PM.



HoD

PRINCIPAL  
Nehru College of  
Engineering and Research Centre  
Pampady, Thiruvilwamala, Thrissur Dt  
Pin 680 597-Kerala



NEHRU COLLEGE OF ENGINEERING AND RESEARCH CENTRE  
(NAAC Accredited)



(Approved by AICTE, Affiliated to APJ Abdul Kalam Technological University, Kerala)

HSDD

Course Goals

1. To learn how to design digital systems, from specification and simulation to construction and debugging.
2. To learn techniques and tools for programmable logic design
3. To learn how to use modern laboratory test equipment, including logic analyzers and oscilloscopes
4. To understand the limitations and difficulties in modern digital design, including wiring constraints, high-speed, etc.
5. To design, construct, test, and debug a moderate-scale digital circuit.

Course Syllabus

1. Review of basic digital-logic design
  - Combinational logic
  - Structured logic implementation
  - Sequential logic
  - Finite-state machines
2. Overview of digital technology
  - Logic families
  - Reading and understanding data books
  - Interfacing
  - Fixed-function devices
    - TTL/CMOS
    - glue logic
    - RAM/ROM
  - Programmable devices
    - PROMs
    - PALs and PLDs
    - FPGAs
  - Integrated circuits
3. Electrical realities
  - Resistance, capacitance and inductance
  - Time constants
  - Decoupling and ground
  - Power dissipation and drops
  - Wire delays
  - Fanout and loading
  - Ringing, reflections, and terminations
  - Clock
4. Computer-aided design
  - Hardware description languages (HDLs, esp. Verilog)
  - Logic compilation
  - Two-level and multi-level logic synthesis
  - Technology-independent optimization
  - Technology mapping
  - Sequential-logic synthesis
  - Tools for mapping to PLDs and FPGAs
5. Laboratory realities
  - Logic analyzer and oscilloscope basics
  - Repetitive versus single-shot triggering
  - Timing, state, capture, bandwidth
  - Glitches and transient events
  - Wire, coax, probing
  - System-level components

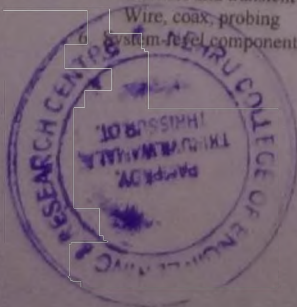

PRINCIPAL  
Nehru College of  
Engineering and Research Centre  
Pattanam, Thiruvananthapuram



NEHRU COLLEGE OF ENGINEERING AND RESEARCH CENTRE  
(NAAC Accredited)

(Approved by AICTE, Affiliated to APJ Abdul Kalam Technological University, Kerala)



COURSE NAME:-HIGH SPEED DIGITAL SYSTEM DESIGN (2014-15)

STUDENTS ENROLLMENT LIST

Reg No	Name
NCANEEC001	Adarsh T.s
NCANEEC002	Aiswarya Arun
NCANEEC003	Aiswarya.u
NCANEEC004	Ajaykrishnan K.b
NCANEEC005	Akshay Dev T V
NCANEEC006	Aljo Laurance
NCANEEC007	Almasfathima M
NCANEEC009	Anakha Jayaraj
NCANEEC010	Anjali P
NCANEEC011	Anjana M G
NCANEEC012	Anjana P
NCANEEC013	Anjitha B
NCANEEC014	Anjitha Rajan
NCANEEC015	Anju V Anil Kumar
NCANEEC016	Anuja P
NCANEEC017	Anusha V
NCANEEC018	Aravind M
NCANEEC019	Arif V M
NCANEEC020	Arjun A C
NCANEEC021	Arjun Babu E P
NCANEEC021	Arjun P
NCANEEC022	Arya S Nair
NCANEEC023	Asish T K



*[Handwritten signature]*

PRINCIPAL  
Nehru College of  
Engineering and Research C  
Parippady, Thiruvithamala, Thr

NCANEEC024	Athira Ms
NCANEEC025	Athira T S
NCANEEC026	Athulya D
NCANEEC027	Athulya Krishna
NCANEEC028	Celestine P Sebastian
NCANEEC029	Divya Benny
NCANEEC030	Divya Mohan M
NCANEEC031	Divya P Nair
NCANEEC032	Divya V
NCANEEC033	Gawtham Krishna Jayan
NCANEEC034	Gokul P
NCANEEC035	Gopika K
NCANEEC036	Greeshma M
NCANEEC037	Greeshma P M
NCANEEC038	Greeta Joy
NCANEEC039	Harikrishnan K S
NCANEEC040	Haritha Menon K P
NCANEEC041	Hisha P.h
NCANEEC046	J Sivasdas
NCANEEC042	Jithin Valiyaveedu
NCANEEC043	Joice C.j
NCANEEC045	Jothish J
NCANEEC047	Keerthana T
NCANEEC048	Keerthi K
NCANEEC049	Keerthy R
NCANEEC050	Lakshmi Priya Nellavarambath
NCANEEC051	Lija Jose
NCANEEC052	Maneesh N
NCANEEC053	Manju M
NCANEEC054	Megha Janardhanan
NCANEEC055	Namitha N
NCANEEC053	Neethu S
NCANEEC053	Sonu B

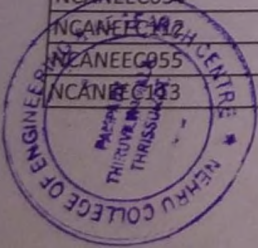

PRINCIPAL  
Nehru College  
Engineering and Technology  
Pampady Thiruvilwamala  
Pin 680 507

NCANEEC110	Aiswarya A
NCANEEC064	Arun Arjun
NCANEEC056	Nibha Baburaj
NCANEEC057	Nikhil P
NCANEEC059	Nisha Siddharthan
NCANEEC060	Nithin Kumar M
NCANEEC061	Nithinsai P.s
NCANEEC062	Nrithya Mihira
NCANEEC063	Pallavi Sethu
NCANEEC065	Parvathy V.p
NCANEEC066	Pavithra Subash
NCANEEC067	Pranav P
NCANEEC068	Pravitha Velayudhan
NCANEEC069	Rahul P R
NCANEEC070	Rahul R
NCANEEC071	Ranjith C
NCANEEC072	Remya Radhakrishnan
NCANEEC073	Reshma C R
NCANEEC075	Reshma R
NCANEEC074	Reshma Ramesan
NCANEEC076	Rishikesh Krishna S
NCANEEC077	Sachin Kumar M
NCANEEC078	Sailesh D
NCANEEC079	Saivishnu S
NCANEEC080	Sana K.a
NCANEEC081	Sangeetha K
NCANEEC082	Sarath K S
NCANEEC083	Shabnam A S
NCANEEC084	Shahma Ks
NCANEEC093	Shilpa S
NCANEEC085	Silpa Arjun
NCANEEC086	Soubarnika S
NCANEEC087	Sradha P.t



*[Handwritten signature]*

**PRINCIPAL**  
Nehru College of  
Engineering and Research Centre  
Pampady, Thiruvananthapuram

NCANEEC088	Sreeja P M
NCANEEC089	Sreejith E.r
NCANEEC090	Sreenath N
NCANEEC114	Srijith C Kumar
NCANEEC091	Sruthi Ravindran
NCANEEC092	Sruthy Mol V
NCANEEC094	Stannars Jose
NCANEEC095	Stephy Joshy
NCANEEC096	Subash James
NCANEEC097	Sudhisagar T G
NCANEEC098	Surjith S
NCANEEC099	Thasni
NCANEEC100	Vandhana N
NCANEEC101	Varsha Jayanand
NCANEEC102	Varsha Muralidharan
NCANEEC103	Vishnu G
NCANEEC104	Vishnu Prasad B
NCANEEC105	Vishnu Radhakrishnan
NCANEEC107	Vishnu S Nair
NCANEEC106	Vishnu Saiesh P
NCANEEC108	Vismaya M Kumar
NCANEEC115	Vysakh P
NCANEEC109	Vyshak K

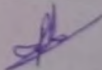
 HOD



  
**PRINCIPAL**  
 Nehru College of  
 Engineering and Research  
 Paripady, Thrippunithura, Thr  
 Pin: 580 547 Kerala

# NEHRU COLLEGE OF ENGINEERING & RESEARCH CENTRE

(Accredited by NAAC)

Pampady, Thiruvilwamala, Thrissur Dt.

Attendance Sheet for Certificate Course "HIGH SPEED DIGITAL SYSTEM DESIGN "

Electronics & Communication Engineering(UG) - (2015-16)Batch



		9/15	10/15	11/15	12/15	1/16	2/16	3/16	4/16	5/16	6/16	7/16	8/16	9/16	10/16	11/16	12/16	1/17	
NCANEEC001	Adarsh T.s	/	/	/	/	/	/	/	/	/	/	/	/	/	/	/	/	/	/
NCANEEC002	Aiswarya Arun	/	/	/	/	/	/	/	/	/	/	/	/	/	/	/	/	/	/
NCANEEC003	Aiswarya.u	/	/	/	/	/	/	/	/	/	/	/	/	/	/	/	/	/	/
NCANEEC004	Ajaykrishnan K.b	/	/	/	/	/	/	/	/	/	/	/	/	/	/	/	/	/	/
NCANEEC005	Akshay Dev T V	/	/	/	/	/	/	/	/	/	/	/	/	/	/	/	/	/	/
NCANEEC006	Aljo Laurance	/	/	/	/	/	/	/	/	/	/	/	/	/	/	/	/	/	/
NCANEEC007	Almasfathima M	/	/	/	/	/	/	/	/	/	/	/	/	/	/	/	/	/	/
NCANEEC009	Anakha Jayaraj	/	/	/	/	/	/	/	/	/	/	/	/	/	/	/	/	/	/
NCANEEC010	Anjali P	/	/	/	/	/	/	/	/	/	/	/	/	/	/	/	/	/	/
NCANEEC011	Anjana M G	/	/	/	/	/	/	/	/	/	/	/	/	/	/	/	/	/	/
NCANEEC012	Anjana P	/	/	/	/	/	/	/	/	/	/	/	/	/	/	/	/	/	/
NCANEEC013	Anjitha B	/	/	/	/	/	/	/	/	/	/	/	/	/	/	/	/	/	/
NCANEEC014	Anjitha Rajan	/	/	/	/	/	/	/	/	/	/	/	/	/	/	/	/	/	/
NCANEEC015	Anju V Anil Kumar	/	/	/	/	/	/	/	/	/	/	/	/	/	/	/	/	/	/
NCANEEC016	Anuja P	/	/	/	/	/	/	/	/	/	/	/	/	/	/	/	/	/	/
NCANEEC017	Anusha V	/	/	/	/	/	/	/	/	/	/	/	/	/	/	/	/	/	/
NCANEEC018	Aravind M	/	/	/	/	/	/	/	/	/	/	/	/	/	/	/	/	/	/
NCANEEC019	Arif V M	/	/	/	/	/	/	/	/	/	/	/	/	/	/	/	/	/	/
NCANEEC020	Arjun A C	/	/	/	/	/	/	/	/	/	/	/	/	/	/	/	/	/	/
NCANEEC021	Arjun Babu E P	/	/	/	/	/	/	/	/	/	/	/	/	/	/	/	/	/	/
NCANEEC111	Arjun P	/	/	/	/	/	/	/	/	/	/	/	/	/	/	/	/	/	/
NCANEEC022	Arya S Nair	/	/	/	/	/	/	/	/	/	/	/	/	/	/	/	/	/	/
NCANEEC023	Asish T K	/	/	/	/	/	/	/	/	/	/	/	/	/	/	/	/	/	/
NCANEEC024	Athira Ms	/	/	/	/	/	/	/	/	/	/	/	/	/	/	/	/	/	/
NCANEEC025	Athira T S	/	/	/	/	/	/	/	/	/	/	/	/	/	/	/	/	/	/
NCANEEC026	Athulya D	/	/	/	/	/	/	/	/	/	/	/	/	/	/	/	/	/	/

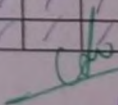

  
**PRINCIPAL**  
 Nehru College of  
 Engineering and Research Centre  
 Pampady, Thiruvilwamala, Thrissur Dt.





NEHRU COLLEGE OF ENGINEERING AND RESEARCH CENTRE  
(NAAC Accredited)

(Approved by AICTE, Affiliated to APJ Abdul Kalam Technological University, Kerala)



COURSE NAME:-HIGH SPEED DIGITAL DESIGN (2015-16)

TOTAL MARKS(30)

1. What is the clock frequency of 8087? a) 10 MHz b) 5 MHz c) 6 MHz d) 4 MHz
2. How are negative numbers stored in a coprocessor? a) 1's complement b) 2's complement c) decimal d) gray
3. How many bits are used for storing signed integers? a) 2 b) 4 c) 8
4. Which of the processor has an internal coprocessor? a) 8087 b) 80287 c) 80387.
5. What are the two major sections in a coprocessor? a) control unit and numeric control unit b) integer unit and control unit c) floating point unit and coprocessor unit d) coprocessor unit and numeric control unit
6. What is 80/20 rule? a) 80% instruction is generated and 20% instruction is executed b) 80% instruction is executed and 20% instruction is generated c) 80% instruction is executed and 20% instruction is not executed d) 80% instruction is generated and 20% instructions are not generated
7. Which of the architecture is more complex?  
a) SPARC b) MC68030 c) MC68030 d) 8086
8. Which is the first company who defined RISC architecture? a) Intel b) IBM c) Motorola d) MIPS
9. Which of the following processors execute its instruction in a single cycle? a) 8086 b) 8088 c) 8087 d) MIPS R2000
10. How is memory accessed in RISC architecture? a) load and store instruction b) opcode instruction c) memory
11. A combinational logic circuit which is used to send data coming from a single source to two or more separate destinations is called  
(a) decoder (b) encoder (c) multiplexer (d) demultiplexer
12. A flip-flop has two outputs which are  
(a) always zero (b) always one  
(c) always complementary (d) all of the above



*cdh*

PRINCIPAL  
Nehru College of  
Engineering and Research Centre  
Thiruvithkumala, Thrissur  
Pin - 686 581



NEHRU COLLEGE OF ENGINEERING AND RESEARCH CENTRE  
(NAAC Accredited)

(Approved by AICTE, Affiliated to APJ Abdul Kalam Technological University, Kerala)



13. A flip-flop can be made using

- (a) basic gates such as AND, OR and NOT
- (b) NAND gates
- (c) NOR gates
- (d) any of above

14. A flip-flop can store

- (a) one bit of data
- (b) two bits of data
- (c) three bits of data
- (d) any number of bits of data

15. A sequential logic circuit consists of

- (a) only flip-flops
- (b) only gates
- (c) flip-flops and combination logic circuits
- (d) only combinational logic circuits

16.  $A+B=B+A$ ;  $AB=BA$  represent which laws

- (a) Commutative
- (b) Associative
- (c) Distributive
- (d) Idempotence

17. The output of a logic gate is 1 when all its inputs are at logic 1, the gate is either

- (a) A NAND or a NOR
- (b) An AND or an OR
- (c) An OR or an X-OR
- (d) An AND or a NOR

18. The output of a logic gate is 1 when all its inputs are at logic 0. The gate is either

- (a) A NAND or a NOR
- (b) An AND or an X-OR
- (c) An OR or a NAND
- (d) An X-OR or an X-NOR

19. Thermocouples are ..... transducers.

- (a) active
- (b) passive
- (c) adhesive
- (d) both (a) and (c)

20. A resistance thermometer is basically a/an

- (a) active transducer
- (b) passive transducer
- (c) potentiometer
- (d) none of these



*Handwritten signature*

PRINCIPAL  
Nehru College of  
Engineering and Research Centre  
Pamady Thiruvamala, Thrissur  
Pin - 680 597 Kerala



**NEHRU COLLEGE OF ENGINEERING AND RESEARCH CENTRE**  
(NAAC Accredited)

(Approved by AICTE, Affiliated to APJ Abdul Kalam Technological University, Kerala)



21. Platinum resistance thermometer can be used up to  
(a) 200°C (b) 850°C (c) 1200°C (d) 1500°C
22. Bourdon tubes have the advantages of  
(a) high accuracy and good dynamic response  
(b) **high sensitivity and good repeatability**  
(c) not being prone to shock vibrations  
(d) not being susceptible to hysteresis
23. A transducer is basically a device which converts  
(a) mechanical energy into electrical  
(b) **energy or information from one form to another**  
(c) mechanical displacement into electrical  
(d) none of these
24. The gauge factor of a strain gauge is given as  
(a)  $G = \Delta R/R / \Delta l/l$  (b)  $G = \Delta l/l / \Delta R/R$   
(c)  $G = \Delta R/R / \Delta D/D$  (d) none of these
25. Thermocouples are generally used for accurate temperature measurement up to  
(a) 350°C (b) 550°C (c) 1400°C (d) 3500°C
26. The principle of operation of LVDT is based on variation of  
(a) self inductance (b) **mutual inductance**  
(c) reluctance (d) permeance
27. Self generating transducers are ..... transducers.  
(a) active (b) passive (c) secondary (d) inverse
28. The transducer that converts the input signal into the output signal, which is a continuous function of time, is known as ..... transducer.  
(a) active (b) **analog** (c) passive (d) digital
29. In semiconductor strain gauges, the change in resistance on application of strain is mainly on account of change in  
(a) length of wire (b) diameter of wire  
(c) **resistivity** (d) both (a) and (b)



**PRINCIPAL**  
Nehru College of  
Engineering and Research Centre  
Muvattupuzha, Thrissur  
No. 488/19/11/2018



**NEHRU COLLEGE OF ENGINEERING AND RESEARCH CENTRE**  
**(NAAC Accredited)**

(Approved by AICTE, Affiliated to APJ Abdul Kalam Technological University, Kerala)



30. The drawback of semiconductor strain gauges are

- (a) low fatigue life (b) poor linearity
- (c) that they are expensive and brittle (d) none of these

HOD

PRINCIPAL

PRINCIPAL

Nehru College of  
Engineering and Research Centre  
Thiruvananthapuram, Kerala  
20/08/2020





**NEHRU COLLEGE OF ENGINEERING AND RESEARCH CENTRE**  
**(NAAC Accredited)**  
(Approved by AICTE, Affiliated to APJ Abdul Kalam Technological University, Kerala)



ANSWER KEY:-HIGH SPEED DIGITAL SYSTEM DESIGN(2015-16)

1)b 2)a 3)b 4)c 5)c 6)c 7)a 8)d 9)b 10)c

11)c 12)a 13)a 14)a 15)b 16)c 17)b 18)a 19)b 20)b

21)c 22)a 23)b 24)a 25)b 26)b 27)a 28)a 29)b 30)a

HOD 

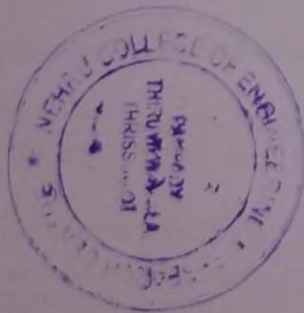

PRINCIPAL

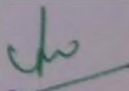
**PRINCIPAL**   
Nehru College of  
Engineering and Research Centre  
Pamppady Thiruvilwamala, Thrissur District  
Kerala  
Pin - 686 597

NCEISE CO25  
A/WIN 12



NEHRU COLLEGE OF ENGINEERING AND RESEARCH CENTRE  
(NAAC Accredited)  
(Approved by AICTE, Affiliated to APJ Abdul Kalam Technological University, Kerala).



26/90

COURSE NAME:-HIGH SPEED DIGITAL DESIGN (2015-16)

TOTAL MARKS(30)

1. What is the clock frequency of 8087? a) 10 MHz b) 5 MHz c) 6 MHz d) 4 MHz
2. How are negative numbers stored in a coprocessor? a) 1's complement b) 2's complement c) decimal d) gray
3. How many bits are used for storing signed integers? a) 2 b) 4 c) 8
4. Which of the processor has an internal coprocessor? a) 8087 b) 80287 c) 80387.
5. What are the two major sections in a coprocessor? a) control unit and numeric control unit b) integer unit and control unit c) floating point unit and coprocessor unit d) coprocessor unit and numeric control unit
6. What is 80/20 rule? a) 80% instruction is generated and 20% instruction is executed b) 80% instruction is executed and 20% instruction is generated c) 80% instruction is executed and 20% instruction is not executed d) 80% instruction is generated and 20% instructions are not generated
7. Which of the architecture is more complex?  
a) SPARC b) MC68030 c) MC68030 d) 8086
8. Which is the first company who defined RISC architecture? a) Intel b) IBM c) Motorola d) MIPS
9. Which of the following processors execute its instruction in a single cycle? a) 8086 b) 8088 c) 8087 d) MIPS R2000
10. How is memory accessed in RISC architecture? a) load and store instruction b) opcode instruction c) memory
11. A combinational logic circuit which is used to send data coming from a single source to two or more separate destinations is called  
(a) decoder (b) encoder (c) multiplexer (d) demultiplexer
12. A flip-flop has two outputs which are  
(a) always zero (b) always one  
(c) always complementary (d) all of the above

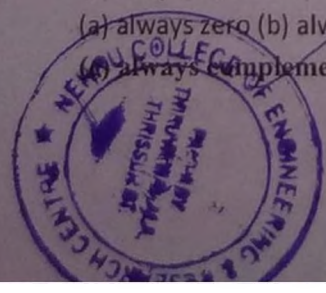

PRINCIPAL  
Nehru College of  
Engineering and  
Research Centre

4



21. Platinum resistance thermometer can be used up to  
(a) 200°C (b) 850°C (c) 1200°C (d) 1500°C
22. Bourdon tubes have the advantages of  
(a) high accuracy and good dynamic response  
(b) high sensitivity and good repeatability  
(c) not being prone to shock vibrations  
(d) not being susceptible to hysteresis
23. A transducer is basically a device which converts  
(a) mechanical energy into electrical  
(b) energy or information from one form to another  
(c) mechanical displacement into electrical  
(d) none of these
24. The gauge factor of a strain gauge is given as  
(a)  $G = \Delta R/R / \Delta l/l$  (b)  $G = \Delta l/l / \Delta R/R$   
(c)  $G = \Delta R/R / \Delta D/D$  (d) none of these
25. Thermocouples are generally used for accurate temperature measurement up to  
(a) 350°C (b) 550°C (c) 1400°C (d) 3500°C
26. The principle of operation of LVDT is based on variation of  
(a) self inductance (b) mutual inductance  
(c) reluctance (d) permeance
27. Self generating transducers are ..... transducers.  
(a) active (b) passive (c) secondary (d) inverse
28. The transducer that converts the input signal into the output signal, which is a continuous function of time, is known as ..... transducer.  
(a) active (b) analog (c) passive (d) digital
29. In semiconductor strain gauges, the change in resistance on application of strain is mainly on account of change in  
(a) length of wire (b) diameter of wire  
(c) resistivity (d) both (a) and (b)

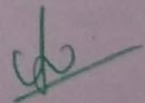

  
PRINCIPAL  
Nehru College of  
Engineering and Research Centre  
Panikayy Thiruvilwamala, Thiruvur  
Pin: 686 587 Kerala



**NEHRU COLLEGE OF ENGINEERING AND RESEARCH CENTRE**  
(NAAC Accredited)  
(Approved by AICTE, Affiliated to APJ Abdul Kalam Technological University, Kerala)



30. The drawback of semiconductor strain gauges are
- (a) low fatigue life
  - (b) poor linearity
  - (c) that they are expensive and brittle
  - (d) none of these

HOB



PRINCIPAL

PRINCIPAL  
Nehru College of  
Engineering and Research Centre  
Panampady Thiruvilwamala, Thiruvananthapuram  
Pin 686 597 Kerala

NCE15EC028

ATHIRA K



NEHRU COLLEGE OF ENGINEERING AND RESEARCH CENTRE

(NAAC Accredited)

(Approved by AICTE, Affiliated to APJ Abdul Kalam Technological University, Kerala)



COURSE NAME:-HIGH SPEED DIGITAL DESIGN (2015-16)

TOTAL MARKS(30)

25/30

1. What is the clock frequency of 8087? a) 10 MHz b) 5 MHz c) 6 MHz d) 4 MHz
2. How are negative numbers stored in a coprocessor? a) 1's complement b) 2's complement c) decimal d) gray
3. How many bits are used for storing signed integers? a) 2 b) 4 c) 8
4. Which of the processor has an internal coprocessor? a) 8087 b) 80287 c) 80387.
5. What are the two major sections in a coprocessor? a) control unit and numeric control unit b) integer unit and control unit c) floating point unit and coprocessor unit d) coprocessor unit and numeric control unit
6. What is 80/20 rule? a) 80% instruction is generated and 20% instruction is executed b) 80% instruction is executed and 20% instruction is generated c) 80% instruction is executed and 20% instruction is not executed d) 80% instruction is generated and 20% instructions are not generated
7. Which of the architecture is more complex?  
a) SPARC b) MC68030 c) MC68030 d) 8086
8. Which is the first company who defined RISC architecture? a) Intel b) IBM c) Motorola d) MIPS
9. Which of the following processors execute its instruction in a single cycle? a) 8086 b) 8088 c) 8087 d) MIPS R2000
10. How is memory accessed in RISC architectures? a) load and store instruction b) opcode instruction c) memory
11. A combinational logic circuit which is used to send data coming from a single source to two or more separate destinations is called  
(a) decoder (b) encoder (c) multiplexer (d) demultiplexer
12. A flip-flop has two outputs which are  
(a) always zero (b) always one  
(c) always complementary (d) all of the above



*Handwritten signature*

PRINCIPAL

Neeru College of  
Engineering and Research Centre  
Mangalapuram, Thiruvananthapuram  
Pin - 695 027 Kerala



NEHRU COLLEGE OF ENGINEERING AND RESEARCH CENTRE  
(NAAC Accredited)  
(Approved by AICTE, Affiliated to APJ Abdul Kalam Technological University, Kerala)



13. A flip-flop can be made using

- (a) basic gates such as AND, OR and NOT
- (b) NAND gates
- (c) NOR gates
- (d) any of above

14. A flip-flop can store

- (a) one bit of data (b) two bits of data
- (c) three bits of data (d) any number of bits of data

15. A sequential logic circuit consists of

- (a) only flip-flops
- (b) only gates
- (c) flip-flops and combination logic circuits
- (d) only combinational logic circuits

16.  $A+B=B+A$ ;  $AB=BA$  represent which laws

- (a) Commutative
- (b) Associative
- (c) Distributive
- (d) Idempotence

17. The output of a logic gate is 1 when all its inputs are at logic 1, the gate is either

- (a) A NAND or a NOR
- (b) An AND or an OR
- (c) An OR or an X-OR
- (d) An AND or a NOR

18. The output of a logic gate is 1 when all its inputs are at logic 0. The gate is either

- (a) A NAND or a NOR
- (b) An AND or an X-OR
- (c) An OR or a NAND
- (d) An X-OR or an X-NOR

19. Thermocouples are ..... transducers.

- (a) active (b) passive (c) adhesive (d) both (a) and (c)

20. A resistance thermometer is basically a/an

- (a) active transducer (b) passive transducer
- (c) potentiometer (d) none of these

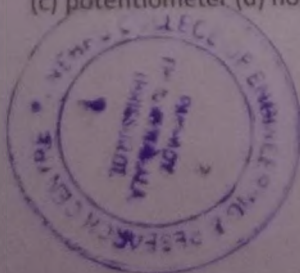

*Handwritten signature*

PRINCIPAL  
Nehru College of  
Engineering and Research Centre  
Pandalay, Thrissur, Kerala  
2018-19



21. Platinum resistance thermometer can be used up to  
(a) 200°C (b) 850°C (c) 1200°C (d) 1500°C
22. Bourdon tubes have the advantages of  
(a) high accuracy and good dynamic response  
(b) high sensitivity and good repeatability  
(c) not being prone to shock vibrations  
(d) not being susceptible to hysteresis
23. A transducer is basically a device which converts  
(a) mechanical energy into electrical  
(b) energy or information from one form to another  
(c) mechanical displacement into electrical  
(d) none of these
24. The gauge factor of a strain gauge is given as  
(a)  $G = \Delta R/R / \Delta l/l$  (b)  $G = \Delta l/l / \Delta R/R$   
(c)  $G = \Delta R/R / \Delta D/D$  (d) none of these
25. Thermocouples are generally used for accurate temperature measurement up to  
(a) 350°C (b) 550°C (c) 1400°C (d) 3500°C
26. The principle of operation of LVDT is based on variation of  
(a) self inductance (b) mutual inductance  
(c) reluctance (d) permeance
27. Self generating transducers are .....transducers.  
(a) active (b) passive (c) secondary (d) inverse
28. The transducer that converts the input signal into the output signal, which is a continuous function of time, is known as .....transducer.  
(a) active (b) analog (c) passive (d) digital
29. In semiconductor strain gauges, the change in resistance on application of strain is mainly on account of change in  
(a) length of wire (b) diameter of wire  
(c) resistivity (d) both (a) and (b)



  
PRINCIPAL  
Nehru College of  
Engineering and Research Centre  
Manjeri, Thiruvananthapuram, Kerala  
Pin - 689 587 Kerala



NEHRU COLLEGE OF ENGINEERING AND RESEARCH CENTRE  
(NAAC Accredited)  
(Approved by AICTE, Affiliated to APJ Abdul Kalam Technological University, Kerala)



30. The drawback of semiconductor strain gauges are
- (a) low fatigue life (b) poor linearity
  - (c) that they are expensive and brittle (d) none of these

HOD

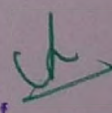

PRINCIPAL

PRINCIPAL   
Nehru College of  
Engineering and Research Centre  
Pariyady Thiruvilwamala, Thiruvananthapuram  
Pin - 686 507 Kerala



NEHRU COLLEGE OF ENGINEERING AND RESEARCH CENTRE  
(NAAC Accredited)  
(Approved by AICTE, Affiliated to APJ Abdul Kalam Technological University, Kerala)



NCEI/SECO/03  
Adesa/Ida/11

COURSE NAME:-HIGH SPEED DIGITAL DESIGN (2015-16)

TOTAL MARKS(30)

27/30

1. What is the clock frequency of 8087? a) 10 MHz b) 5 MHz c) 6 MHz d) 4 MHz
2. How are negative numbers stored in a coprocessor? a) 1's complement b) 2's complement c) decimal d) gray
3. How many bits are used for storing signed integers? a) 2 b) 4 c) 8
4. Which of the processor has an internal coprocessor? a) 8087 b) 80287 c) 80387.
5. What are the two major sections in a coprocessor? a) control unit and numeric control unit b) integer unit and control unit c) floating point unit and coprocessor unit d) coprocessor unit and numeric control unit
6. What is 80/20 rule? a) 80% instruction is generated and 20% instruction is executed b) 80% instruction is executed and 20% instruction is generated c) 80% instruction is executed and 20% instruction is not executed d) 80% instruction is generated and 20% instructions are not generated
7. Which of the architecture is more complex?  
a) SPARC b) MC68030 c) MC68030 d) 8086
8. Which is the first company who defined RISC architecture? a) Intel b) IBM c) Motorola d) MIPS
9. Which of the following processors execute its instruction in a single cycle? a) 8086 b) 8088 c) 8087 d) MIPS R2000
10. How is memory accessed in RISC architecture? a) load and store instruction b) opcode instruction c) memory
11. A combinational logic circuit which is used to send data coming from a single source to two or more separate destinations is called  
(a) decoder (b) encoder (c) multiplexer (d) demultiplexer
12. A flip-flop has two outputs which are  
(a) always zero (b) always one  
(c) always complementary (d) all of the above



Ad

PRINCIPAL  
Nehru College of  
Engineering and Research Centre  
Panasey, Thiruvithamala, Thrissur  
Pin - 686 587 Kerala



13. A flip-flop can be made using

- (a) basic gates such as AND, OR and NOT
- (b) NAND gates
- (c) NOR gates
- (d) any of above

14. A flip-flop can store

- (a) one bit of data
- (b) two bits of data
- (c) three bits of data
- (d) any number of bits of data

15. A sequential logic circuit consists of

- (a) only flip-flops
- (b) only gates
- (c) flip-flops and combination logic circuits
- (d) only combinational logic circuits

16.  $A+B=B+A$ ;  $AB=BA$  represent which laws

- (a) Commutative
- (b) Associative
- (c) Distributive
- (d) Idempotence

17. The output of a logic gate is 1 when all its inputs are at logic 1, the gate is either

- (a) A NAND or a NOR
- (b) An AND or an OR
- (c) An OR or an X-OR
- (d) An AND or a NOR

18. The output of a logic gate is 1 when all its inputs are at logic 0. The gate is either

- (a) A NAND or a NOR
- (b) An AND or an X-OR
- (c) An OR or a NAND
- (d) An X-OR or an X-NOR

19. Thermocouples are \_\_\_\_\_ transducers.

- (a) active
- (b) passive
- (c) adhesive
- (d) both (a) and (c)

20. A resistance thermometer is basically a/an

- (a) active transducer
- (b) passive transducer
- (c) potentiometer
- (d) none of these

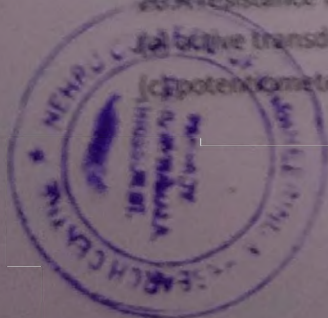

PRINCIPAL  
Nehru College of  
Engineering and Research Centre  
Kandiyathuruvilamala Thiruvananthapuram  
Pin: 695 012



21. Platinum resistance thermometer can be used up to  
(a) 200°C (b) 850°C (c) 1200°C (d) 1500°C
22. Bourdon tubes have the advantages of  
(a) high accuracy and good dynamic response  
(b) high sensitivity and good repeatability  
(c) not being prone to shock vibrations  
(d) not being susceptible to hysteresis
23. A transducer is basically a device which converts  
(a) mechanical energy into electrical  
(b) energy or information from one form to another  
(c) mechanical displacement into electrical  
(d) none of these
24. The gauge factor of a strain gauge is given as  
(a)  $G = \Delta R/R / \Delta l/l$  (b)  $G = \Delta l/l / \Delta R/R$   
(c)  $G = \Delta R/R / \Delta D/D$  (d) none of these
25. Thermocouples are generally used for accurate temperature measurement up to  
(a) 350°C (b) 550°C (c) 1400°C (d) 3500°C
26. The principle of operation of LVDT is based on variation of  
(a) self inductance (b) mutual inductance  
(c) reluctance (d) permeance
27. Self generating transducers are ..... transducers.  
(a) active (b) passive (c) secondary (d) inverse
28. The transducer that converts the input signal into the output signal, which is a continuous function of time, is known as ..... transducer.  
(a) active (b) analog (c) passive (d) digital
29. In semiconductor strain gauges, the change in resistance on application of strain is mainly on account of change in  
(a) length of wire (b) diameter of wire  
(c) resistivity (d) both (a) and (b)

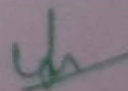

  
PRINCIPAL  
Nehru College of  
Engineering and Research Cent  
Pamsey, Thiruvananthapuram, Kerala  
Ph: 880 582 8444



**NEHRU COLLEGE OF ENGINEERING AND RESEARCH CENTRE**  
(NAAC Accredited)

(Approved by AICTE, Affiliated to APJ Abdul Kalam Technological University, Kerala)



30. The drawback of semiconductor strain gauges are
- (a) low fatigue life
  - (b) poor linearity
  - (c) that they are expensive and brittle
  - (d) none of these

HOD



PRINCIPAL

PRINCIPAL

Nehru College of

Engineering and Research Centre

Thiruvilwamala, Thiruvananthapuram

Pin: 688 597 Kerala







NEHRU COLLEGE OF ENGINEERING  
AND RESEARCH CENTRE



*Certificate of Recognition*

This certificate is awarded to

ASHUJ I K (NCANEEL023)

for completing Addon course on HIGH-SPEED DIGITAL DESIGN  
from 5/10/15 to 5/11/15 conducted by ECE  
Dept NCERC, Pampady

*[Signature]*

COURSE COORDINATOR

*[Signature]*

HOD

*[Signature]*

PRINCIPAL  
NCERC



*[Signature]*

PRINCIPAL  
Nehru College of  
Engineering and Research Centre  
Pampady, Thiruvilwamala, Thrissur Dt  
Pin: 686 597 Kerala



NEHRU COLLEGE OF ENGINEERING  
AND RESEARCH CENTRE



*Certificate of Recognition*

This certificate is awarded to

ASHIRA T.S (NCANEELODS)

for completing Addon course on HIGH SPEED DIGITAL DESIGN  
from 5/8/15 to 5/10/15 conducted by ECE  
Dept NCERC, Pampady

COURSE COODINATOR

HOD

PRINCIPAL  
NCERC



PRINCIPAL  
Nehru College of  
Engineering and Research Centre  
Pampady Thiruvilwamala, Thrissur Dt  
Pin: 586 597 Kerala



NEHRU COLLEGE OF ENGINEERING  
AND RESEARCH CENTRE



*Certificate of Recognition*

This certificate is awarded to

(NCAEECO21) ARJUN BABU EP

for completing Addon course on HIGH SPEED DIGITAL DESIGN  
from 5/8/15 to 5/10/15 conducted by ECE  
Dept NCERC, Pampady

COURSE COODINATOR

HOD

PRINCIPAL  
NCERC



PRINCIPAL  
Nehru College of  
Engineering and Research Centre  
Pampady, Thiruvilwamala, Thrissur Dt.  
Pin 680 597 Kerala



NEHRU COLLEGE OF ENGINEERING  
AND RESEARCH CENTRE



*Certificate of Recognition*

This certificate is awarded to

(MCA/EECOIT) ANITHA B

for completing Addon course on HIGH SPEED DIGITAL DESIGN  
from 5/8/15 to 5/14/15 conducted by ECT  
Dept NCEEC, Pampady

98

COURSE COORDINATOR

It

DOB

Anitha B

PRINCIPAL  
NCEEC

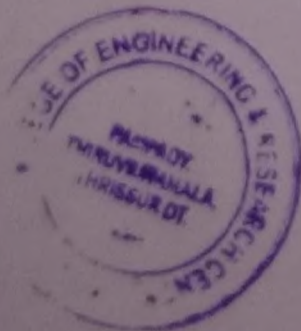

Ch

PRINCIPAL

Nehru College of  
Engineering and Research Centre  
Pampady Thiruvankulam, Thrissur Dt  
Pin 680 557 Kerala



NEHRU COLLEGE OF ENGINEERING  
AND RESEARCH CENTRE



*Certificate of Recognition*

This certificate is awarded to

MCEEDSB (JAYARAJANAN, N.K)

for completing Addon course on HIGH SPEED DIGITAL SYSTEMS  
from 5/8/15 to 5/10/15 conducted by ECE  
Dept NCERC, Pampady

*[Signature]*

COURSE COORDINATOR

*[Signature]*

Head

*[Signature]*

PRINCIPAL  
NCERC



PRINCIPAL *[Signature]*  
Nehru College of  
Engineering and Research Centre  
Pampady, Thrissur  
Ph: 02-44-4444



**NEHRU COLLEGE OF ENGINEERING AND RESEARCH CENTRE**  
(NAAC Accredited)  
(Approved by AICTE, Affiliated to APJ Abdul Kalam Technological University, Kerala)



**NEHRU COLLEGE OF ENGINEERING AND RESEARCH CENTRE**  
(ACCREDITED BY NAAC)

**PAMPADY, THIRUVILWAMALA, THRISSUR DIST.**

**ADD ON/CERTIFICATE COURSE ON HIGH SPEED DIGITAL DESIGN**

DEPARTMENT OF ELECTRONICS AND COMMUNICATION is welcoming all students of ECE department to attend an ADD ON/CERTIFICATE Course on 'HIGH SPEED DIGITAL DESIGN' starting from 10-05-2015. All students of U.G admissions of ECE department are eligible to attend this course. The course will enhance the knowledge level of students in programming and understanding of digital circuits .

Course coordinator:-Mrs Sajitha A S(Asst Prof.ECE Dept,NCERC)

Starting date:-10-05-2015

Ending date:-07-07-2015

Duration:- 35 hours

An objective type exam will be conducted after the completion of classes

Students obtaining a minimum of 50 percent marks in the exam will be provided with the course certificate on behalf of NEHRU COLLEGE OF ENGINEERING AND RESEARCH CENTRE PAMPADY, THRISSUR.

Exam Date:-12-07-2015

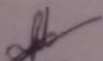
  
HOD

PRINCIPAL

**PRINCIPAL**   
Nehru College of  
Engineering and Research Centre  
Pampady, Thiruvilwamala, Thrissur  
Pin - 686 567 Kerala





NEHRU COLLEGE OF ENGINEERING AND RESEARCH CENTRE



(NAAC Accredited)

(Approved by AICTE, Affiliated to APJ Abdul Kalam Technological University, Kerala)

ELECTRONICS AND COMMUNICATION DEPARTMENT

NOTICE

30.07.2015

Department has decided to conduct a certificate course on "PCB FABRICATION " on second and fourth Saturdays during this academic year 2015-16. The duration of the course will be for a period of 32 hours. The objective of the course is to impart knowledge on principles of PCB fabrication. This course will act as a key for enhancing know how of students to design and implement the electronic circuits

The 2013-17 and 2014-18 batch admissions (UG) of ECE department are eligible for this course. All concerned students should attend the entire course without fail. Attendance is compulsory.

Copy:

1. Department Notice Board
2. Staff advisors (For Information to students)
3. Office file

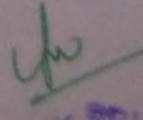

  
HoD  
  
PRINCIPAL  
Neeru College of  
Engineering and Research  
Pampady, Thiruvivaranjala,  
Thiruvananthapuram



NEHRU COLLEGE OF ENGINEERING AND RESEARCH CENTRE  
(NAAC Accredited)



Approved by AICTE, Affiliated to APJ Abdul Kalam Technological University, Kerala)

FROM,

SAJITHA A S,

ASSISTANT PROFESSOR,

ECE DEPARTMENT, NCERC, PAMPADY.

TO,

THE PRINCIPAL,

NCERC, PAMPADY.

Through HOD

Respected Sir/Madam

SUBJECT:-Request for conducting a certificate Course Reg.

Department of Electronics & communication Engineering, NCERC, is planning to conduct an Add-On Course on "PCB FABRICATION & DESIGNING" from 4-8-15. The course is scheduled as a 30hour program. The main objective of this course is to provide students an understanding of designing and fabrication of Printed Circuit Boards. Kindly request you to grant the permission for conducting the sessions.

All UG/ Students of ECE Dept,are eligible for this course.

Thanking you for your consideration. I look forward to your response soon.

Yours sincerely,

Place:

Date:

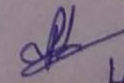
  
HOD

*Permitted*

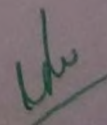



NEHRU COLLEGE OF ENGINEERING AND RESEARCH CENTRE  
(NAAC Accredited)  
(Approved by AICTE, Affiliated to APJ Abdul Kalam Technological University, Kerala)



NEHRU COLLEGE OF ENGINEERING AND RESEARCH CENTRE

(ACCREDITED BY NAAC)

PAMPADY, THIRUVILWAMALA, THRISSUR DIST.

MINUTES OF DEPARTMENT ADVISORY COMMITTEE MEETING HELD ON 07/04/2015

A meeting of the Department Advisory Committee (DAC) was held on 7<sup>th</sup> April 2015 at 11:00 AM in the chamber of HoD, ECE department.

The following members were present:

1. Dr S Rajkumar-HoD, ECE Dept.
2. Mr. Raghu M C-Assistant Professor, ECE Dept.
3. Mr. Vishnu Prabha N Kaimal- ECE Dept
4. Mr Rahul M Nair Assistant Professor, ECE Dept.
5. Mrs. Sajitha A S-Assistant Professor, ECE Dept.

The following decisions were taken:

1. It was decided to conduct a certificate course on "PCB FABRICATION PRINCIPLES" from 10/5/2015 for a period of 30 hours.
2. The course will enhance the knowledge level of students in designing and understanding the layouts of circuits.
3. It was decided to provide the course for 2012-16 batch UG students.
4. Also, it was decided to ensure compulsory attendance and staff advisors should monitor the same.

The meeting came to an end at 11:40 AM.

  
HoD

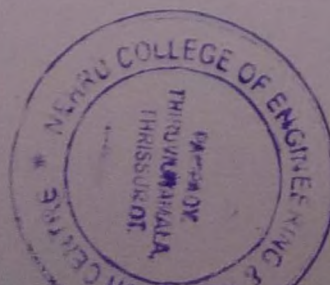

PRINCIPAL

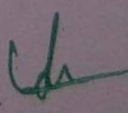
  
PRINCIPAL  
Nehru College of  
Engineering and Research Centre  
Pampady Thiruvilwamala, Thrissur Dist  
Pin 680 597 Kerala



NEHRU COLLEGE OF ENGINEERING AND RESEARCH CENTRE  
(NAAC Accredited)

(Approved by AICTE, Affiliated to APJ Abdul Kalam Technological University, Kerala)



## “Printed Circuit Board (PCB) Designing”

### Objective of the Course:

This is a basic course for designing of PCB using software. PCB (Printed Circuit Board) designing is an integral part of each electronics products and this program is designed to make students capable to design their own projects PCB up to industrial grade.

### Topics Covered:

1. Introduction to PCB designing concepts
2. Component introduction and their categories
3. Introduction to Development Tools
4. Detailed description and practical of PCB designing
5. Lab practice and designing concepts

### Detailed Syllabus of the Course

#### Section 1: Introduction to PCB designing concepts

##### Introduction & Brief History

- What is PCB
- Difference between PWB and PCB
- Types of PCBs: Single Sided (Single Layer), Multi-Layer (Double Layer)
- PCB Materials

##### Introduction to Electronic design Automation (EDA)

- Brief History of EDA
- Latest Trends in Market
- How it helps and Why it requires
- Different EDA tools
- Introduction to SPICE and PSPICE Environment
- Introduction and Working of PROTEUS

#### Section 2: Component introduction and their categories

##### Types of Components

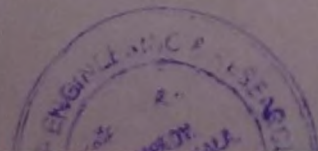

cb



VEHRU COLLEGE OF ENGINEERING AND RESEARCH CENTRE  
(NAAC Accredited)

(Approved by AICTE, Affiliated to APJ Abdul Kalam Technological University, Kerala)



COURSE NAME:-PCB FABRICATION (2015-16)

STUDENTS ENROLLMENT LIST

NCAOEEC001	Adarsh Gopalakrishnan
NCAOEEC002	Adharsh Haridas
NCAOEEC003	Aishwarya
NCAOEEC004	Aiswarya K
NCAOEEC005	Aiswarya S.k
NCAOEEC006	Aiswarya Unnikrishnan V
NCAOEEC007	Ajin C.u
NCAOEEC008	Akhila K G
NCAOEEC009	Akhila P P
NCAOEEC012	Akshay Balagopal
NCAOEEC013	Akshay K.p
NCAOEEC011	Akshaya J.r
NCAOEEC014	Albin Benny
NCAOEEC015	Amrutha M
NCAOEEC016	Anees P.t
NCAOEEC017	Anjali K.u
NCAOEEC018	Anjali Peradath
NCAOEEC019	Anjali Purushothaman
NCAOEEC020	Anjana Gopinath
NCAOEEC021	Anjana P
NCAOEEC022	Anusree K M
NCAOEEC023	Aparna P



Engr  
Pampa

NC ACH C 001	Agarwal S
NC ACH C 002	Agarwal C
NC ACH C 003	Agarwal Ashish S
NC ACH C 004	Agarwal V
NC ACH C 005	Agarwal S
NC ACH C 006	Agarwal Rishabh
NC ACH C 007	Agarwal Tanu S
NC ACH C 008	Agarwal N S
NC ACH C 009	Agarwal M
NC ACH C 010	Agarwal P
NC ACH C 011	Agarwal S
NC ACH C 012	Agarwal Das S
NC ACH C 013	Agarwal S
NC ACH C 014	Chakraborty G
NC ACH C 015	Chakraborty S
NC ACH C 016	Chakraborty K P
NC ACH C 017	Chakraborty M C
NC ACH C 018	Chakraborty D
NC ACH C 019	Chakraborty Parthasarathi
NC ACH C 020	Chakraborty M
NC ACH C 021	Chakraborty V
NC ACH C 022	Chakraborty P
NC ACH C 023	Chakraborty Das
NC ACH C 024	Chakraborty V
NC ACH C 025	Chakraborty Mariam Bajan
NC ACH C 026	Chakraborty S
NC ACH C 027	Chakraborty K
NC ACH C 028	Chakraborty K
NC ACH C 029	Chakraborty T
NC ACH C 030	Chakraborty C
NC ACH C 031	Chakraborty K S
NC ACH C 032	Chakraborty P
NC ACH C 033	Chakraborty P



*(Handwritten signature)*

**PRINCIPAL**  
 Vellore College of  
 Engineering and Research Center  
 Vellore, Tamil Nadu, India  
 Pin: 622 002

NCAOECC058	Malavika M.s
NCAOECC059	Manjunath V
NCAOECC060	Manu Km
NCAOECC062	Mubsira. A
NCAOECC063	Muthukumaran N.k
NCAOECC064	Nayana K
NCAOECC065	Nidhi S Nair
NCAOECC066	Nikhil Kizhiyapat
NCAOECC067	Nimisha P.n
NCAOECC068	Nithuna S
NCAOECC069	Nuaaman
NCAOECC070	Parvathi Dinesh
NCAOECC071	Radhika P.t
NCAOECC072	Rahana K.m
NCAOECC073	Rinza Fathima Z
NCAOECC074	Roshna V C
NCAOECC075	Sachinma M
NCAOECC076	Sanfiya S
NCAOECC077	Sangeetha S
NCAOECC078	Sanjiv K
NCAOECC079	Saranya C
NCAOECC080	Sethupriyan
NCAOECC081	Shahana A
NCAOECC082	Shahul Hameed
NCAOECC083	Sharon S
NCAOECC084	Shima A.m
NCAOECC085	Sneha K
NCAOECC103	Sneha Vs
NCAOECC086	Sona V.r
NCAOECC087	Sreejith P.m
NCAOECC088	Sreerexha K K
NCAOECC089	Sreevalsan.r.
NCAOECC090	Sruthy P



CAOEEC091	Sudhamsu S
CAOEEC092	Sujitha K
CAOEEC093	Sukanya C R
CAOEEC094	Sumaya K.s
CAOEEC095	Surya K.r
CAOEEC096	Thasfiya M K
CAOEEC097	Vaisakh Dinesh
CAOEEC098	Veena V
CAOEEC099	Vineeth Krishnan P
CAOEEC104	Vishal Kumar V
CAOEEC100	Vishnu C
CAOEEC101	Vishnu D.m
CAOEEC102	Vishnu Sathyan
CAOEEC105	Yadhukrishnan P

 HOD

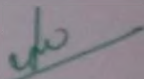
  
**PRINCIPAL**  
 Nehru College of  
 Engineering and Research Centre  
 Pampady, Thuvilwamala, Thrissur Dt.  
 Pin - 588 567 Kerala



# NEHRU COLLEGE OF ENGINEERING & RESEARCH CENTRE

(Accredited by NAAC)

Pampady, Thiruvilwamala, Th



Attendance Sheet for Certificate Course "PCB FABRICATION PRINCIPLES "

Electronics & Communication Engineering(UG) - (2015-16)Batch

		3/4/16	9/4/16	14/4	19/4	24/4	29/4	1/5	6/5	11/5	16/5	21/5	26/5	31/5	5/6	10/6	15/6	20/6	25/6	30/6	5/7	10/7
NCAMEEC001	Aathira R	/	/	/	/	/	/	/	/	/	/	/	/	/	/	/	/	/	/	/	/	/
NCAMEEC002	Abhijith K	/	/	/	/	/	/	/	/	/	/	/	/	/	/	/	/	/	/	/	/	/
NCAMEEC003	Adhrisya V	/	/	/	/	/	/	/	/	/	/	/	/	/	/	/	/	/	/	/	/	/
NCAMEEC004	Afna Mamu	/	/	/	A	/	/	/	/	/	/	/	/	/	/	/	/	/	/	/	/	/
NCAMEEC005	Aisha Chandhni	/	/	/	/	/	/	/	/	/	/	/	/	/	/	/	/	/	/	/	/	/
NCAMEEC006	Aiswarya M.s	/	/	/	/	/	/	/	/	/	/	/	/	/	/	/	/	/	/	/	/	/
NCAMEEC131	Aiswarya R	/	/	/	/	/	A	/	/	/	/	/	/	/	/	/	/	/	/	/	/	/
NCAMEEC007	Allen Emmanuel Joe	/	A	/	/	/	/	/	/	/	/	/	/	/	/	/	/	/	/	A	/	/
NCAMEEC008	Amal Deep S	/	/	/	/	/	/	/	/	/	/	/	/	/	/	/	/	/	/	/	/	/
NCAMEEC009	Ambili C	/	/	/	/	/	/	/	/	/	/	/	/	/	/	/	/	/	/	/	/	/
NCAMEEC010	Amritha P	/	/	/	/	/	/	/	/	/	/	/	/	/	/	/	/	/	/	/	/	/
NCAMEEC011	Amrutha J	/	/	/	/	/	/	/	/	/	/	/	/	/	/	/	/	/	/	/	/	/
NCAMEEC012	Amrutha V	/	/	/	/	/	/	/	/	/	/	/	/	/	/	/	/	/	/	/	/	/
NCAMEEC013	Anand Abraham	/	/	/	A	/	/	/	/	/	/	/	/	/	/	/	/	/	/	/	/	/
NCAMEEC014	Aneena B	/	/	/	/	/	/	/	/	/	/	/	/	/	/	/	/	/	/	/	/	/
NCAMEEC015	Aneesh A, S/o.anandhan A.r	/	/	/	/	/	/	/	/	A	/	/	/	/	/	/	/	/	/	A	A	/
NCAMEEC016	Anija K.p	/	/	/	/	/	/	/	/	/	/	/	/	/	/	/	/	/	/	/	/	/
NCAMEEC017	Anjali B	/	/	/	/	/	/	/	/	/	/	/	/	/	/	/	/	/	/	/	/	/
NCAMEEC018	Anjali Rajesh P.r	/	/	/	A	/	/	/	/	/	/	/	/	/	/	/	/	/	/	/	/	/
NCAMEEC019	Anjali.s	/	/	/	/	/	/	/	/	/	/	/	/	/	/	/	/	/	/	/	/	/
NCAMEEC132	Anju P	/	/	/	/	/	/	/	/	/	/	/	/	/	/	/	/	/	/	/	/	/
NCAMEEC020	Anu Lakshmi K.r	/	/	/	/	/	/	/	/	/	/	/	/	/	/	/	/	/	/	/	/	/
NCAMEEC021	Aparna A.p	/	/	/	/	/	/	/	/	/	/	/	/	/	/	/	/	/	/	/	/	/
NCAMEEC022	Arifa K	/	/	/	/	/	/	/	/	/	/	/	/	/	/	/	/	/	/	/	/	/
NCAMEEC023	Arya Das.r	/	/	/	/	/	/	/	/	/	/	/	/	/	/	/	/	/	/	/	/	/
NCAMEEC024	Arya J	/	/	/	/	/	/	/	/	/	/	/	/	/	/	/	/	/	/	/	/	/

THIRUVILWAMALA  
THRISSUR, OT

PRINCIP







COURSE NAME: PCB FABRICATION PRINCIPLES (2015-16)

TOTAL MARKS (30)

- Q.1. Electron-hole pairs are produced by  
(a) recombination (b) thermal energy (c) ionization (d) doping
- Q.2. Recombination is when  
(a) an electron falls into a hole  
(b) a positive and a negative ion bond together  
(c) a valence electron becomes a conduction electron  
(d) a crystal is formed
- Q.3. Each atom in a silicon crystal has  
(a) four valence electrons  
(b) four conduction electrons  
(c) eight valence electrons, four of its own and four shared  
(d) no valence electrons because all are shared with other atoms
- Q.4. The current in a semiconductor is produced by  
(a) electrons only (b) holes only (c) negative ions (d) both electrons and holes
- Q.5. The process of adding an impurity to an intrinsic semiconductor is called  
(a) doping (b) recombination (c) atomic modification (d) ionization
- Q.6. A trivalent impurity is added to silicon to create  
(a) germanium (b) a p-type semiconductor  
(c) an n-type semiconductor (d) a depletion region
- Q.7. The purpose of pentavalent impurity is to  
(a) reduce the conductivity (b) increase the number of holes  
(c) increase the number of free electrons (d) create minority carriers

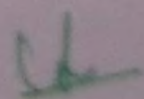

  
PRINCIPAL  
Nehru College of  
Engineering and Research Centre  
Thiruvananthapuram  
Kerala



**NEHRU COLLEGE OF ENGINEERING AND RESEARCH CENTRE**  
(NAAC Accredited)  
(Approved by AICTE, Affiliated to APJ Abdul Kalam Technological University, Kerala)



- Q.8. For a silicon diode, the value of the forward-bias voltage typically  
(a) must be greater than 0.3V (b) must be greater than 0.7V  
(c) depends on the width of depletion region (d) depends on the concentration of majority carriers
- Q.9. When forward biased, a diode  
(a) blocks current (b) conducts current  
(c) has a high resistance (d) drops a large voltage
- Q.10. When a voltmeter is placed across a forward-biased diode, it will read a voltage approximately equal to  
(a) the bias battery voltage (b) 0V  
(c) the diode barrier potential (d) the total circuit voltage
- Q.11. The term bias means  
(a) the ratio of majority carriers to minority carriers  
(b) the amount of current across a diode  
(c) a dc voltage is applied to control the operation of a device  
(d) none of the above
- Q.12. In a LED, the light is produced by a solid state process called as  
(a) light radiation (b) electroluminescence (c) light multiplication (d) phosphorescence
- Q.13. Efficiency of LED is given by  
(a) light to light conversion (b) light to electrical conversion  
(c) electrical power to visible light conversion (d) none of above
- Q.14. The wavelength of the light emitted and its color depends on the  
(a) forward voltage (b) forward current  
(c) band gap energy of the material forming P-N junction (d) none of the above
- Q.15. The material used for red LED is  
(a) GaP (b) GaAsP (c) AlGaAs (d) Above all
- Q.16. A silicon diode is in series with a 1.0 kΩ resistor and a 5V battery. If the anode is connected to the positive battery terminal, the cathode voltage with respect to the negative battery terminal is  
(a) 0.7V (b) 0.3V (c) 5.7V (d) 4.3V
- Q.17. Although current is blocked in reverse bias,  
(a) there is some current due to majority carrier  
(b) there is very small current due to minority carriers  
(c) there is an avalanche current  
(d) none of the above

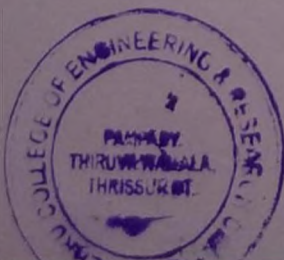

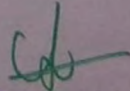
  
**PRINCIPAL**  
Nehru College of  
Engineering and Research Centre  
Thiruvilwamala, Thrissur Dist.  
Pin: 688 597 Kerala



- Q.18. The average value of a half wave rectified voltage with a peak value of 200V is  
(a) 63.7V (b) 127.3V (c) 141V (d) 0V
- Q.19. When a 60Hz sinusoidal voltage is applied to the input of a half-wave rectifier, the output frequency is  
(a) 120Hz (b) 30Hz (c) 60Hz (d) 0Hz
- Q.20. The peak value of the input to a half-wave rectifier is 10V. The approximate peak value of the output is  
(a) 10V (b) 3.18V (c) 10.7V (d) 9.3V
- Q.21. The average value of full-wave rectified voltage with a peak value of 75V is  
(a) 53V (b) 47.8V (c) 37.5V (d) 23.9V
- Q.22. When a 60Hz sinusoidal voltage is applied to the input of a full-wave rectifier, the output frequency is  
(a) 120Hz (b) 60Hz (c) 240Hz (d) 0Hz
- Q.23. The total secondary voltage in a center-tapped full-wave rectifier is 125Vrms. Neglecting the diode drop, the rms output voltage is  
(a) 125V (b) 177V (c) 100V (d) 62.5V
- Q.24. When the peak output voltage is 100V, the PIV for each diode in a center-tapped full-wave rectifier is (neglecting the diode drop)  
(a) 100V (b) 200V (c) 141V (d) 50V
- Q.25. The ideal dc output voltage of a capacitor-input filter is equal to  
(a) The peak value of the rectified voltage  
(b) The average value of the rectified voltage  
(c) The rms value of the rectified voltage  
(d) None of the above
- Q.26. If the load resistance of a capacitor-filtered full-wave rectifier is reduced, the ripple voltage  
(a) increases (b) decreases (c) is not affected (d) has a different frequency
- Q.27. If one of the diodes in a bridge full-wave rectifier opens, the output is approximately  
(a) 0V (b) one-fourth the amplitude of the input voltage  
(c) a half-wave rectified voltage (d) a 120Hz voltage
- Q.28. The cathode of zener diode in a voltage regulator is normally  
(a) more positive than the anode (b) more negative than the anode  
(c) at +0.7 V (d) grounded

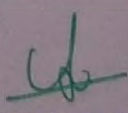

  
**PRINCIPAL**  
Nehru College of  
Engineering and Research Centre  
Panipady Thiruvilwamala, Thrissur Dt  
Pin: 680 597 Kerala



NEHRU COLLEGE OF ENGINEERING AND RESEARCH CENTRE  
(NAAC Accredited)

(Approved by AICTE, Affiliated to APJ Abdul Kalam Technological University, Kerala)



Q.29.If a certain zener diode has a zener voltage of 3.6V, it operates in

- (a) regulated breakdown (b) Zener breakdown  
(c) forward conduction (d) avalanche breakdown

Q.30.The data sheet for a particular zener gives  $V_Z=10V$  at  $I_{ZT}=500mA$ .  $Z_Z$  for these conditions is

- (a)  $50\Omega$  (b)  $20\Omega$  (c)  $10\Omega$  (d) unknown

HOD

PRINCIPAL

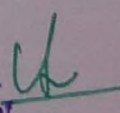

PRINCIPAL   
Nehru College of  
Engineering and Research Centre  
Thiruvilwamala, Thiruvananthapuram  
Pin - 680 507, Kerala



**NEHRU COLLEGE OF ENGINEERING AND RESEARCH CENTRE**  
(Approved by AICTE, Affiliated to APJ Abdul Kalam Technological University, Kerala)



ANSWER KEY:-PCB FABRICATION PRINCIPLES (2015-16)

1)b 2)c 3)a 4)b 5)a 6)b 7)c 8)d 9)b 10)a

11)c 12)a 13)b 14)d 15)a 16)b 17)c 18)b 19)c 20)a

21)b 22)c 23)d 24)a 25)b 26)c 27)a 28)b 29)b 30)c

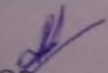
HOD 

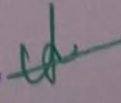

PRINCIPAL  
PRINCIPAL   
Nehru College of  
Engineering and Research Centre  
Pampady, Thiruvikramamala, Thrissur Dist.  
Pin - 680 597 Kerala



NEHRU COLLEGE OF ENGINEERING AND RESEARCH CENTRE  
(NAAC Accredited)  
(Approved by AICTE, Affiliated to APJ Abdul Kalam Technological University, Kerala)



NCA NEECO24  
ATHIRA M.S

25/30

COURSE NAME: PCB FABRICATION PRINCIPLES(2015-16)

TOTAL MARKS(30)

Q.1. Electron-hole pair are produced by  
(a) recombination (b) thermal energy (c) ionization (d) doping

Q.2. Recombination is when  
(a) an electron falls into a hole  
(b) a positive and a negative ion bond together  
(c) a valence electron becomes a conduction electron  
(d) a crystal is formed

Q.3. Each atom in a silicon crystal has  
(a) four valence electrons  
(b) four conduction electrons  
(c) eight valence electrons, four of its own and four shared  
(d) no valence electrons because all are shared with other atoms

Q.4. The current in a semiconductor is produced by  
(a) electrons only (b) holes only (c) negative ions (d) both electrons and holes

Q.5. The process of adding an impurity to an intrinsic semiconductor is called  
(a) doping (b) recombination (c) atomic modification (d) ionization

Q.6. A trivalent impurity is added to silicon to create  
(a) germanium (b) a p-type semiconductor  
(c) an n-type semiconductor (d) a depletion region

Q.7. The purpose of pentavalent impurity is to  
(a) reduce the conductivity (b) increase the number of holes  
(c) increase the number of free electrons (d) create minority carriers

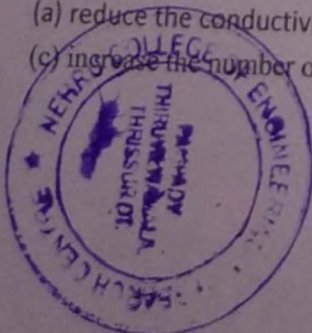

*Ch*

PRINCIPAL  
Nehru College of  
Engineering and Research Centre  
Pampady Thiruvilwamala, Thrissur @  
Pin 686 597 Kerala



**NEHRU COLLEGE OF ENGINEERING AND RESEARCH CENTRE**  
(NAAC Accredited)

(Approved by AICTE, Affiliated to APJ Abdul Kalam Technological University, Kerala)



- Q.8. For a silicon diode, the value of the forward-bias voltage typically  
(a) must be greater than 0.3V (b) must be greater than 0.7V  
(c) depends on the width of depletion region (d) depends on the concentration of majority carriers
- Q.9. When forward biased, a diode  
(a) blocks current (b) conducts current  
(c) has a high resistance (d) drops a large voltage
- Q.10. When a voltmeter is placed across a forward-biased diode, it will read a voltage approximately equal to  
(a) the bias battery voltage (b) 0V  
(c) the diode barrier potential (d) the total circuit voltage
- Q.11. The term bias means  
(a) the ratio of majority carriers to minority carriers  
(b) the amount of current across a diode  
(c) a dc voltage is applied to control the operation of a device  
(d) none of the above
- Q.12. In a LED, the light is produced by a solid state process called as  
(a) light radiation (b) electroluminescence (c) light multiplication (d) phospherence
- Q.13. Efficiency of LED is given by  
(a) light to light conversion (b) light to electrical conversion  
(c) electrical power to visible light conversion (d) none of above
- Q.14. The wavelength of the light emitted and its color depends on the  
(a) forward voltage (b) forward current  
(c) band gap energy of the material forming P-N junction (d) none of the above
- Q.15. The material used for red LED is  
(a) GaP (b) GaAsP (c) AlGaAs (d) Above all
- Q.16. A silicon diode is in series with a 1.0 k $\Omega$  resistor and a 5V battery. If the anode is connected to the positive battery terminal, the cathode voltage with respect to the negative battery terminal is  
(a) 0.7V (b) 0.3V (c) 5.7V (d) 4.3V
- Q.17. Although current is blocked in reverse bias,  
(a) there is some current due to majority carrier  
(b) there is very small current due to minority carriers  
(c) there is an avalanche current  
(d) none of the above



*Handwritten signature*

PRINCIPAL  
Nehru College of  
Engineering and Research Centre  
APJ Abdul Kalam Technological University, Kerala



NEHRU COLLEGE OF ENGINEERING AND RESEARCH CENTRE  
(NAAC Accredited)

(Approved by AICTE, Affiliated to APJ Abdul Kalam Technological University, Kerala)



- Q.18. The average value of a half wave rectified voltage with a peak value of 200V is  
(a) 63.7V (b) 127.3V (c) 141V (d) 0V
- Q.19. When a 60Hz sinusoidal voltage is applied to the input of a half-wave rectifier, the output frequency is  
(a) 120Hz (b) 30Hz (c) 60Hz (d) 0Hz
- Q.20. The peak value of the input to a half-wave rectifier is 10V. The approximate peak value of the output is  
(a) 10V (b) 3.18V (c) 10.7V (d) 9.3V
- Q.21. The average value of full-wave rectified voltage with a peak value of 75V is  
(a) 53V (b) 47.8V (c) 37.5V (d) 23.9V
- Q.22. When a 60Hz sinusoidal voltage is applied to the input of a full-wave rectifier, the output frequency is  
(a) 120Hz (b) 60Hz (c) 240Hz (d) 0Hz
- Q.23. The total secondary voltage in a center-tapped full-wave rectifier is 125Vrms. Neglecting the diode drop, the rms output voltage is  
(a) 125V (b) 177V (c) 100V (d) 62.5V
- Q.24. When the peak output voltage is 100V, the PIV for each diode in a center-tapped full-wave rectifier is (neglecting the diode drop)  
(a) 100V (b) 200V (c) 141V (d) 50V
- Q.25. The ideal dc output voltage of a capacitor-input filter is equal to  
(a) The peak value of the rectified voltage  
(b) The average value of the rectified voltage  
(c) The rms value of the rectified voltage  
(d) None of the above
- Q.26. If the load resistance of a capacitor-filtered full-wave rectifier is reduced, the ripple voltage  
(a) increases (b) decreases (c) is not affected (d) has a different frequency
- Q.27. If one of the diodes in a bridge full-wave rectifier opens, the output is approximately  
(a) 0V (b) one-fourth the amplitude of the input voltage  
(c) a half-wave rectified voltage (d) a 120Hz voltage
- Q.28. The cathode of zener diode in a voltage regulator is normally  
(a) more positive than the anode (b) more negative than the anode  
(c) at 0V (d) grounded

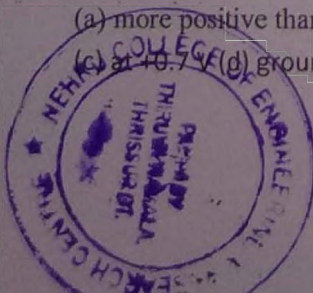

*cd*

PRINCIPAL  
Nehru College of  
Engineering and Research Centre  
Thiruvilwamala, Thiruvananthapuram

19  
VPM



**NEHRU COLLEGE OF ENGINEERING AND RESEARCH CENTRE**  
**(NAAC Accredited)**

(Approved by AICTE, Affiliated to APJ Abdul Kalam Technological University, Kerala)



Q.29. If a certain zener diode has a zener voltage of 3.6V, it operates in

- (a) regulated breakdown (b) Zener breakdown
- (c) forward conduction (d) avalanche breakdown

Q.30. The data sheet for a particular zener gives  $V_Z = 10V$  at  $I_{ZT} = 500mA$ .  $Z_Z$  for these conditions is

- (a) 50Ω (b) 20Ω (c) 10Ω (d) unknown

HOD

PRINCIPAL

PRINCIPAL

Nehru College of  
Engineering and Research Centre  
Kannur, Thiruvananthapuram, Kerala  
Pin: 689 087, Kerala





NCAN 0019  
ARIF VM

20/30

COURSE NAME: PCB FABRICATION PRINCIPLES(2015-16)

TOTAL MARKS(30)

Q.1. Electron-hole pair are produced by

- (a) recombination (b) thermal energy (c) ionization (d) doping

Q.2. Recombination is when

- (a) an electron falls into a hole  
(b) a positive and a negative ion bond together  
(c) a valence electron becomes a conduction electron  
(d) a crystal is formed

Q.3. Each atom in a silicon crystal has

- (a) four valence electrons  
(b) four conduction electrons  
(c) eight valence electrons, four of its own and four shared  
(d) no valence electrons because all are shared with other atoms

Q.4. The current in a semiconductor is produced by

- (a) electrons only (b) holes only (c) negative ions (d) both electrons and holes

Q.5. The process of adding an impurity to an intrinsic semiconductor is called

- (a) doping (b) recombination (c) atomic modification (d) ionization

Q.6. A trivalent impurity is added to silicon to create

- (a) germanium (b) a p-type semiconductor  
(c) an n-type semiconductor (d) a depletion region

Q.7. The purpose of pentavalent impurity is to

- (a) reduce the conductivity (b) increase the number of holes  
(c) increase the number of free electrons (d) create minority carriers

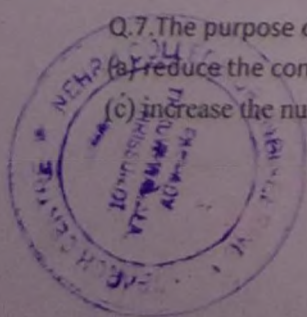

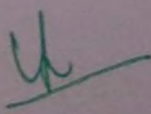
  
PRINCIPAL  
Nehru College of  
Engineering and Research Centre  
Manjeri, Thiruvilwamala, Thrissur  
Pin 680 502



NEHRU COLLEGE OF ENGINEERING AND RESEARCH CENTRE  
(NAAC Accredited)

(Approved by AICTE, Affiliated to APJ Abdul Kalam Technological University, Kerala)



- Q.8. For a silicon diode, the value of the forward-bias voltage typically  
(a) must be greater than 0.3V (b) must be greater than 0.7V  
(c) depends on the width of depletion region (d) depends on the concentration of majority carriers
- Q.9. When forward biased, a diode  
(a) blocks current (b) conducts current  
(c) has a high resistance (d) drops a large voltage
- Q.10. When a voltmeter is placed across a forward-biased diode, it will read a voltage approximately equal to  
(a) the bias battery voltage (b) 0V  
(c) the diode barrier potential (d) the total circuit voltage
- Q.11. The term bias means  
(a) the ration of majority carriers to minority carriers  
(b) the amount of current across a diode  
(c) a dc voltage is applied to control the operation of a device  
(d) none of the above
- Q.12. In a LED, the light is produced by a solid state process called as  
(a) light radiation (b) electroluminescence (c) light multiplication (d) phospherence
- Q.13. Efficiency of LED is given by  
(a) light to light conversion (b) light to electrical conversion  
(c) electrical power to visible light conversion (d) none of above
- Q.14. The wavelength of the light emitted and its color depends on the  
(a) forward voltage (b) forward current  
(c) band gap energy of the material forming P-N junction (d) none of the above
- Q.15. The material used for red LED is  
(a) GaP (b) GaAsP (c) AlGaAs (d) Above all
- Q.16. A silicon diode is in series with a 1.0 k $\Omega$  resistor and a 5V battery. If the anode is connected to the positive battery terminal, the cathode voltage with respect to the negative battery terminal is  
(a) 0.7V (b) 0.3V (c) 5.7V (d) 4.3V
- Q.17. Although current is blocked in reverse bias,  
(a) there is some current due to majority carrier  
(b) there is very small current due to minority carriers  
(c) there is an avalanche current  
(d) none of the above

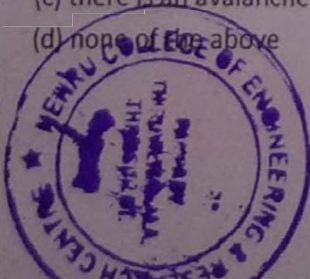

*Handwritten signature*

PRINCIPAL  
Nehru College of  
Engineering and Research Centre  
Panampilly Thiruvilwamala, Thrissur



**NEHRU COLLEGE OF ENGINEERING AND RESEARCH CENTRE**  
(NAAC Accredited)

(Approved by AICTE, Affiliated to APJ Abdul Kalam Technological University, Kerala)



- Q.18. The average value of a half wave rectified voltage with a peak value of 200V is  
(a) 63.7V (b) 127.3V (c) 141V (d) 0V
- Q.19. When a 60Hz sinusoidal voltage is applied to the input of a half-wave rectifier, the output frequency is  
(a) 120Hz (b) 30Hz (c) 60Hz (d) 0Hz
- Q.20. The peak value of the input to a half-wave rectifier is 10V. The approximate peak value of the output is  
(a) 10V (b) 3.18V (c) 10.7V (d) 9.3V
- Q.21. The average value of full-wave rectified voltage with a peak value of 75V is  
(a) 53V (b) 47.8V (c) 37.5V (d) 23.9V
- Q.22. When a 60Hz sinusoidal voltage is applied to the input of a full-wave rectifier, the output frequency is  
(a) 120Hz (b) 60Hz (c) 240Hz (d) 0Hz
- Q.23. The total secondary voltage in a center-tapped full-wave rectifier is 125Vrms. Neglecting the diode drop, the rms output voltage is  
(a) 125V (b) 177V (c) 100V (d) 62.5V
- Q.24. When the peak output voltage is 100V, the PIV for each diode in a center-tapped full-wave rectifier is (neglecting the diode drop)  
(a) 100V (b) 200V (c) 141V (d) 50V
- Q.25. The ideal dc output voltage of a capacitor-input filter is equal to  
(a) The peak value of the rectified voltage  
(b) The average value of the rectified voltage  
(c) The rms value of the rectified voltage  
(d) None of the above
- Q.26. If the load resistance of a capacitor-filtered full-wave rectifier is reduced, the ripple voltage  
(a) increases (b) decreases (c) is not affected (d) has a different frequency
- Q.27. If one of the diodes in a bridge full-wave rectifier opens, the output is approximately  
(a) 0V (b) one-fourth the amplitude of the input voltage  
(c) a half-wave rectified voltage (d) a 120Hz voltage
- Q.28. The cathode of zener diode in a voltage regulator is normally  
(a) more positive than the anode (b) more negative than the anode  
(c) at +0.7 V (d) grounded



*cd*  
PRINCIPAL  
Nehru College of  
Engineering and Research Centre  
Pampady Thiruvilwamala, Thiruvananthapuram  
Pin 680 597 Kerala



**NEHRU COLLEGE OF ENGINEERING AND RESEARCH CENTRE**  
**(NAAC Accredited)**

(Approved by AICTE, Affiliated to APJ Abdul Kalam Technological University, Kerala)



Q.29.If a certain zener diode has a zener voltage of 3.6V,it operates in

- (a) regulated breakdown (b) Zener breakdown  
(c) forward conduction (d) avalanche breakdown

Q.30.The data sheet for a particular zener gives  $V_Z=10V$  at  $I_{ZT}=500mA$ .  $Z_Z$  for these conditions is

- (a)  $50\Omega$  (b)  $20\Omega$  (c)  $10\Omega$  (d) unknown

HOD 

PRINCIPAL

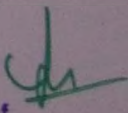
PRINCIPAL   
Nehru College of

Engineering and Research Centre  
Pambady Thiruvilwamala, Thrissur  
Pin 686 597 Kerala



NCA NEECB14

Amilha Rajon



NEHRU COLLEGE OF ENGINEERING AND RESEARCH CENTRE  
(NAAC Accredited)

(Approved by AICTE, Affiliated to APJ Abdul Kalam Technological University, Kerala)



2020

COURSE NAME: PCB FABRICATION PRINCIPLES(2015-16)

TOTAL MARKS(30)

Q.1. Electron-hole pair are produced by

- (a) recombination (b) thermal energy (c) ionization (d) doping

Q.2. Recombination is when

- (a) an electron falls into a hole  
(b) a positive and a negative ion bond together  
(c) a valence electron becomes a conduction electron  
(d) a crystal is formed

Q.3. Each atom in a silicon crystal has

- (a) four valence electrons  
(b) four conduction electrons  
(c) eight valence electrons, four of its own and four shared  
(d) no valence electrons because all are shared with other atoms

Q.4. The current in a semiconductor is produced by

- (a) electrons only (b) holes only (c) negative ions (d) both electrons and holes

Q.5. The process of adding an impurity to an intrinsic semiconductor is called

- (a) doping (b) recombination (c) atomic modification (d) ionization

Q.6. A trivalent impurity is added to silicon to create

- (a) germanium (b) a p-type semiconductor  
(c) an n-type semiconductor (d) a depletion region

Q.7. The purpose of pentavalent impurity is to

- (a) reduce the conductivity (b) increase the number of holes  
(c) increase the number of free electrons (d) create minority carriers



*Handwritten signature*

PRINCIPAL  
Nehru College of  
Engineering and Research Centre



NEHRU COLLEGE OF ENGINEERING AND RESEARCH CENTRE  
(NAAC Accredited)

(Approved by AICTE, Affiliated to APJ Abdul Kalam Technological University, Kerala)



Q.8. For a silicon diode, the value of the forward-bias voltage typically

- (a) must be greater than 0.3V
- (b) must be greater than 0.7V
- (c) depends on the width of depletion region
- (d) depends on the concentration of majority carriers

Q.9. When forward biased, a diode

- (a) blocks current
- (b) conducts current
- (c) has a high resistance
- (d) drops a large voltage

Q.10. When a voltmeter is placed across a forward-biased diode, it will read a voltage approximately equal to

- (a) the bias battery voltage
- (b) 0V
- (c) the diode barrier potential
- (d) the total circuit voltage

Q.11. The term bias means

- (a) the ratio of majority carriers to minority carriers
- (b) the amount of current across a diode
- (c) a dc voltage is applied to control the operation of a device
- (d) none of the above

Q.12. In a LED, the light is produced by a solid state process called as

- (a) light radiation
- (b) electroluminescence
- (c) light multiplication
- (d) phospherence

Q.13. Efficiency of LED is given by

- (a) light to light conversion
- (b) light to electrical conversion
- (c) electrical power to visible light conversion
- (d) none of above

Q.14. The wavelength of the light emitted and its color depends on the

- (a) forward voltage
- (b) forward current
- (c) band gap energy of the material forming P-N junction
- (d) none of the above

Q.15. The material used for red LED is

- (a) GaP
- (b) GaAsP
- (c) AlGaAs
- (d) Above all

Q.16. A silicon diode is in series with a 1.0 kΩ resistor and a 5V battery. If the anode is connected to the positive battery terminal, the cathode voltage with respect to the negative battery terminal is

- (a) 0.7V
- (b) 0.3V
- (c) 5.7V
- (d) 4.3V

Q.17. Although current is blocked in reverse bias,

- (a) there is some current due to majority carrier
- (b) there is very small current due to minority carriers
- (c) there is an avalanche current
- (d) none of the above

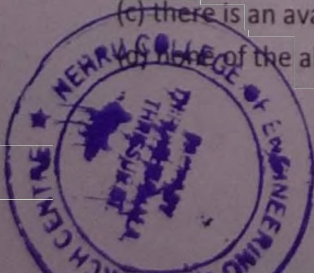

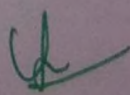
  
PRINCIPAL  
Nehru College of



**NEHRU COLLEGE OF ENGINEERING AND RESEARCH CENTRE**  
(NAAC Accredited)

(Approved by AICTE, Affiliated to APJ Abdul Kalam Technological University, Kerala)



- Q.18. The average value of a half wave rectified voltage with a peak value of 200V is  
(a) 63.7V (b) 127.3V (c) 141V (d) 0V
- Q.19. When a 60Hz sinusoidal voltage is applied to the input of a half-wave rectifier, the output frequency is  
(a) 120Hz (b) 30Hz (c) 60Hz (d) 0Hz
- Q.20. The peak value of the input to a half-wave rectifier is 10V. The approximate peak value of the output is  
(a) 10V (b) 3.18V (c) 10.7V (d) 9.3V
- Q.21. The average value of full-wave rectified voltage with a peak value of 75V is  
(a) 53V (b) 47.8V (c) 37.5V (d) 23.9V
- Q.22. When a 60Hz sinusoidal voltage is applied to the input of a full-wave rectifier, the output frequency is  
(a) 120Hz (b) 60Hz (c) 240Hz (d) 0Hz
- Q.23. The total secondary voltage in a center-tapped full-wave rectifier is 125Vrms. Neglecting the diode drop, the rms output voltage is  
(a) 125V (b) 177V (c) 100V (d) 62.5V
- Q.24. When the peak output voltage is 100V, the PIV for each diode in a center-tapped full-wave rectifier is (neglecting the diode drop)  
(a) 100V (b) 200V (c) 141V (d) 50V
- Q.25. The ideal dc output voltage of a capacitor-input filter is equal to  
(a) The peak value of the rectified voltage  
(b) The average value of the rectified voltage  
(c) The rms value of the rectified voltage  
(d) None of the above
- Q.26. If the load resistance of a capacitor-filtered full-wave rectifier is reduced, the ripple voltage  
(a) increases (b) decreases (c) is not affected (d) has a different frequency
- Q.27. If one of the diodes in a bridge full-wave rectifier opens, the output is approximately  
(a) 0V (b) one-fourth the amplitude of the input voltage  
(c) a half-wave rectified voltage (d) a 120Hz voltage
- Q.28. The cathode of zener diode in a voltage regulator is normally  
(a) more positive than the anode (b) more negative than the anode  
(c) at +0.7V (d) grounded

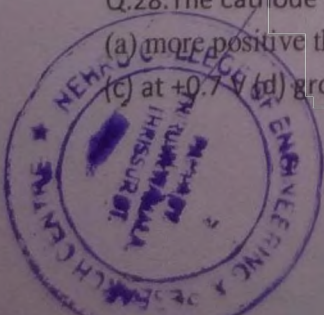

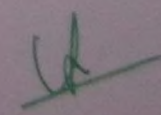
  
PRINCIPAL  
Nehru College of  
Engineering and Research Centre  
Pampady, Thiruvilwamala



NEHRU COLLEGE OF ENGINEERING AND RESEARCH CENTRE  
(NAAC Accredited)

(Approved by AICTE, Affiliated to APJ Abdul Kalam Technological University, Kerala)



Q.29.If a certain zener diode has a zener voltage of 3.6V,it operates in

- (a) regulated breakdown (b) Zener breakdown  
(c) forward conduction (d) avalanche breakdown

Q.30.The data sheet for a particular zener gives  $V_Z=10V$  at  $I_{ZT}=500mA$ .  $Z_Z$  for these conditions is

- (a)  $50\Omega$  (b)  $20\Omega$  (c)  $10\Omega$  (d) unknown

HOD

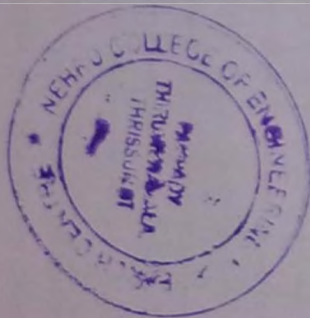

PRINCIPAL

PRINCIPAL   
Nehru College of  
Engineering and Research Centre  
Panambay Thiruvilwamala, Thiruvananthapuram  
Pin - 684 597 Kerala









NEHRU COLLEGE OF ENGINEERING  
AND RESEARCH CENTRE



*Certificate of Recognition*

This certificate is awarded to

NCEEC032 (CHARUTHA .C)

for completing Addon course on PCB FABRICATION  
from 4/8/17 to 4/14/17 conducted by ECE  
Dept NCERC, Pampady

*[Signature]*

COURSE COORDINATOR

*[Signature]*

HoD

*[Signature]*

PRINCIPAL  
NCERC

PRINCIPAL *[Signature]*  
Nehru College of  
Engineering and Research Centre  
Pampady Thiruvilwamala, Thrissur  
Pin 680 597 Kerala

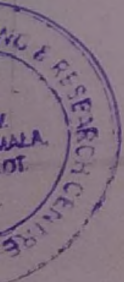



NEHRU COLLEGE OF ENGINEERING  
AND RESEARCH CENTRE



*Certificate of Recognition*

This certificate is awarded to

NCAMEECOLB (ANAND.A)

for completing Addon course on 'PCB FABRICATION'  
from 4/3/15 to 4/10/15 conducted by ECE  
Dept NCERC, Pampady

*[Signature]*

COURSE COODINATOR

*[Signature]*

HOD

*[Signature]*

PRINCIPAL  
NCERC



*[Signature]*

PRINCIPAL

Nehru College of  
Engineering and Research Centre  
Pampady Thiruvilwamala, Thrissur Dt  
Pin - 680 507 Kerala



NEHRU COLLEGE OF ENGINEERING  
AND RESEARCH CENTRE



*Certificate of Recognition*

This certificate is awarded to

AMRUTHA V (NCAHEEC012)

for completing Addon course on PCB FABRICATION  
from 4/9/15 to 4/10/15 conducted by ECE  
Dept NCERC, Pampady

*Abi*

COURSE COODINATOR

*[Signature]*

HOD

*[Signature]*

PRINCIPAL  
NCERC



*[Signature]*

PRINCIPAL  
Nehru College of  
Engineering and Research Centre  
Pampady, Thiruvilwamala, Thrissur Dt  
Pin: 680 597 Kerala



NEHRU COLLEGE OF ENGINEERING  
AND RESEARCH CENTRE



*Certificate of Recognition*

This certificate is awarded to

ARYA I (NCAMEE1024)

for completing Addon course on PCB FABRICATION  
from 4/8/15 to 4/10/15 conducted by ECE  
Dept NCERC, Pampady

COURSE COODINATOR

HOD

PRINCIPAL  
NCERC

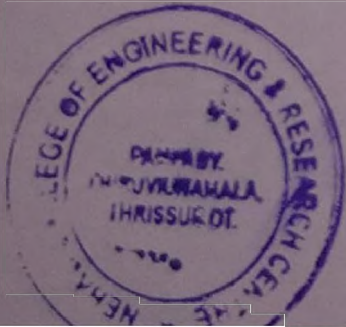

PRINCIPAL  
Nehru College of  
Engineering and Research Centre  
Pampady, Thiruvilwamala, Thirissur Dt  
Pin 680 597 Kerala



NEHRU COLLEGE OF ENGINEERING  
AND RESEARCH CENTRE



*Certificate of Recognition*

This certificate is awarded to

ANJALI B (NCAEE013)

for completing Addon course on PSS FABRICATION  
from 4/8/15 to 4/10/15 conducted by ECE  
Dept NCFRC, Pampady

COURSE COORDINATOR

HOD

PRINCIPAL

No. 436

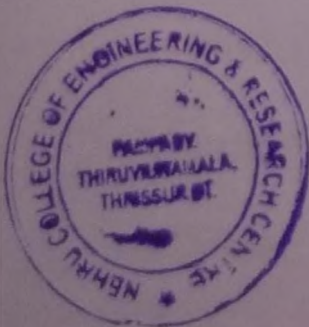

PRINCIPAL

Nehru College of  
Engineering and Research Centre  
Pampady Thiruvithamala, Thrissur Dt  
Pin 680 507 Kerala



**NEHRU COLLEGE OF ENGINEERING AND RESEARCH CENTRE  
(NAAC Accredited)**

(Approved by AICTE, Affiliated to APJ Abdul Kalam Technological University, Kerala)



# **Master of Computer Applications**



NEHRU COLLEGE OF ENGINEERING AND RESEARCH CENTRE  
(NAAC Accredited)  
(Approved by AICTE, Affiliated to APJ Abdul Kalam Technological University, Kerala)



NEHRU COLLEGE OF ENGINEERING AND RESEARCH CENTRE  
(ACCREDITED BY NAAC)

PAMPADY, THIRUVILWAMALA, THRISSUR DIST.

ADD ON/CERTIFICATE COURSE ON PCB FABRICATION

DEPARTMENT OF ELECTRONICS AND COMMUNICATION is welcoming all students of ECE department to attend an ADD ON/CERTIFICATE Course on 'PCB FABRICATION' starting from 10-05-2015. All students of U.G admissions of ECE department are eligible to attend this course. The course will enhance the knowledge level of students in programming and understanding of digital circuits .

Course coordinator:-Mr Vishnu Prabha N Kiaml(Asst Prof.ECE Dept,NCERC)

Starting date:-10-05-2015

Ending date:-07-07-2015

Duration:- 35 hours

An objective type exam will be conducted after the completion of classes

Students obtaining a minimum of 50 percent marks in the exam will be provided with the course certificate on behalf of NEHRU COLLEGE OF ENGINEERING AND RESEARCH CENTRE PAMPADY, THRISSUR.

Exam Date:-10-07-2015

  
HOD

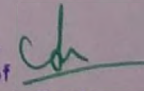

PRINCIPAL

PRINCIPAL   
Nehru College of  
Engineering and Research Centre  
Pampady Thiruvilwamala, Thrissur Dist  
Pin - 680 597 Kerala

# Nehru College Of Engineering & Research Centre, Pampady

Department of MCA

Circular

This is to inform you that the Department of MCA is conducting value added course on Web Designing from 16/11/15 to 27/11/15. Attendance is compulsory.

Pampady

03/11/15

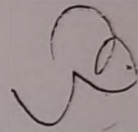

HOD MCA

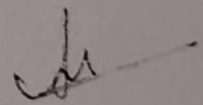
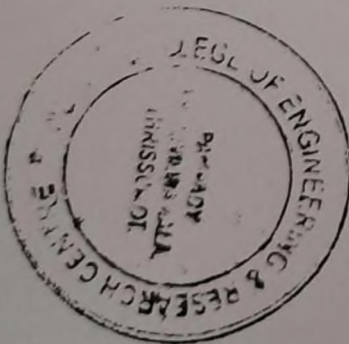

PRINCIPAL  
Nehru College of  
Engineering and Research Centre  
Pampady, Taluk, Ponnani, Malappuram  
Pin - 686 597 Kerala

NEHRU COLLEGE OF ENGINEERING AND RESEARCH CENTRE

DEPARTMENT OF MCA

Minutes of Meeting conducted on 10/11/2015

1. Principal's approval dt. 16<sup>th</sup> – 27<sup>th</sup> November 2015 for Value Added courses
2. Topic of VA Course is fixed as Web Designing
3. The syllabus may cover HTML, CSS, Client and Server Side Scripts and their applications
4. Class tutors must motivate the students to take the course seriously
5. Evaluation may be done through Quiz, Written Exams and Group activities
6. Certificates for successful students may be provided

Coordinator – VA Courses-MCA

Faculty Attendees

Dr.Sudheer.S.Marar 

Pramod K 

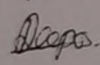
Deepa A 

Student Attendees

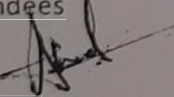
Abdul Basith 

Faida 

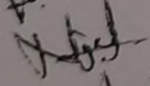
Nijeesh 

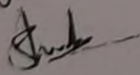
Sheeba Krishna 

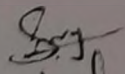
Sreejith 

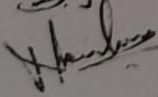
Neelima 

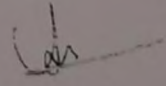

  
PRINCIPAL  
Nehru College of  
Engineering and Research Centre  
Pampady, Thiruvilwamala, Thrissur Dt  
Pin 680 597 Kerala

# Nehru College Of Engineering & Research Centre, Pampady

Department of MCA

Circular

This is to inform you that the Department of MCA is conducting value added course on Web Designing from 16/11/15 to 27/11/15. Attendance is compulsory.

Pampady

03/11/15

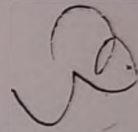

HOD MCA

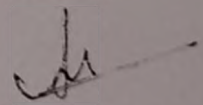
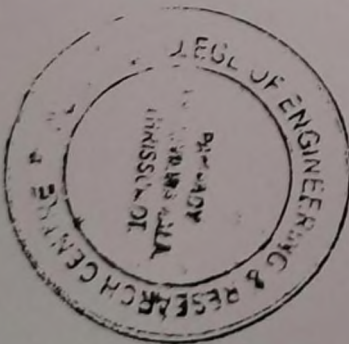

PRINCIPAL  
Nehru College of  
Engineering and Research Centre  
Pampady, Taluk, Ponnani, District  
Pin - 686 597 Kerala

# NEHRU COLLEGE OF ENGINEERING AND RESEARCH CENTRE

## DEPARTMENT OF MCA

### SYLLABUS FOR WEBDESIGNING

#### HTML

#### Introduction

- Introduction
- A Brief Overview

#### HTML Tags

- HTML Document Type Overview
- The Outer Structure of an HTML Document: Part
- The Outer Structure of an HTML Document: Part
- Creating and Using Templates
- HTML and Text
- Paragraphs
- Block and Inline Tags
- Controlling Line Breaks and Spaces
- Phrase Elements
- Font-Markup Elements
- Quotations and Quote Marks
- Pre-Formatted Text using the PRE Tag
- Aligning Paragraphs
- HTML Lists
- Selecting a Typeface using the FONT Tag
- Selecting a Type Size using the FONT Tag
- Introduction to Hyperlinks
- Absolute and Relative URLs
- Specifying a Different Base for Relative URLs
- Adding Titles to Your Links
- Fragments: Linking to a Segment of a Page

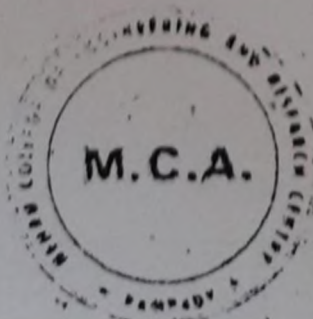

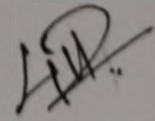
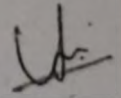
  
  
PRINCIPAL  
Nehru College of  
Engineering and Research Centre  
Panapady Thiruvilwamala, Thiruvananthapuram  
Pin: 686 597 Kerala

NEHRU COLLEGE OF ENGINEERING AND RESEARCH CENTRE

MCA DEPARTMENT 2015 – 2016

SCHEDULE WEB DESIGNING 16<sup>th</sup> – 27<sup>th</sup> Nov 2015

No	Date	Portions Covered
1	16	HTML Basics
2	17	TAGS
3	18	XML
4	19	FORMS
5	20	JAVASCRIPT
6	23	PHP BASICS
7	24	PHP OPERATORS
8	25	XAMPP
9	26	PHP & MYSQL
10	27	DATABASE CONNECTIVITY

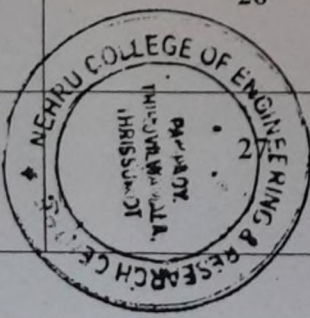

*ch*

PRINCIPAL  
Nehru College of  
Engineering and Research Centre  
Panipady Thiruvilwamala Thiruvananthapuram  
Pin 680 597 Kerala

*[Handwritten signature]*

NEHRU COLLEGE OF ENGINEERING AND RESEARCH CENTRE

MCA DEPARTMENT 2015 - 2016

NAME LIST OF STUDENTS

16<sup>th</sup> - 27<sup>th</sup> Nov 2015

No.	Name
1	ABDUL BASITH
2	AMBIKA P
3	AMRUTHA SANKARANARAYANAN
4	ANJU S
5	CHINJU SHAJI
6	DHEERAJ DAS
7	DIVYA P M
8	FAIDAH BEEVI A T
9	JJI KRISHNA P R
10	JOTHI I
11	MUHAMMED FIROZ
12	NAVANEETH KRISHNAN P
13	PAVITHRA K
14	RAMEEZ M
15	RESHMA M
16	SAJIN C P
17	SONY K.
18	SREENATH T M
19	SUNIL .V
20	VISHNU M
21	AISWARYA K
22	AISWARYA R
23	AMAL N P
24	ANJU K
25	ANJU S
26	ANNAPOORNI K G
27	ANUMOL ANTONY
28	ASWATHI.V.
29	DIVYA P
30	GANESH NARAYANAN
31	HIMA S
32	HONEY XAVIER
33	JISHA P J
34	JITHU POUL
35	KEERTHY A R
36	KRISHNA PRIYA. S.
37	KRISHNA SHARMA K
38	LAKSHMIDEVI M V
39	MANSOOR E
40	MANU KRISHNAN K
41	MEERADEVI M
42	NAIR ANISHA BALAKRISHNAN
43	NEERAJ KRISHNAN P
44	NEON K K

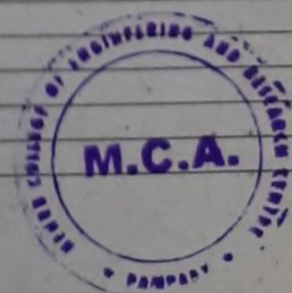

PRINCIPAL

Nehru College of  
Engineering and Research Centre,  
Pampady, Thiruvilwamala, Thrissur Dt.

*[Handwritten signature]*

*[Handwritten signature]*

45	NIJEESH P R
46	PREETHI K
47	PRIYANKA RAJ S
48	REVATHY T C
49	SHAMEEMA K P
50	SHEEBA A
51	SHILPA RAMESH P
52	SMINUMOL E S
53	SOMYA N
54	SONI K
55	SUDHISHMA T
56	VIBITHA C
57	VISHAL P V
58	AISWARYA K R
59	AJESH A J
60	ASHA JOHNY
61	ASHITHA B Y
62	ATHIRA O M
63	BINDHU BALACHANDRAN
64	DEVI KRISHNA P R
65	DIPIN K S
66	DIVYA K
67	FAYIS K T
68	JAYASREE P
69	JIBIN VARGHESE
70	MOHAMMED RAOFAL
71	NAMITHA P S
72	NANCY KOCHOUSEPH
73	NEELIMA M P
74	NIDHILA K
75	PRESSY MATHEW
76	RAIBY M BENNY
77	SHAMILA M I
78	SHOBICA KAILAS S
79	SNEHA MOHAN P
80	SREEJITH K
81	SUBAIR A S
82	SUMI M



**PRINCIPAL**

Nehru College of  
Engineering and Research Centre  
Pampady Thiruvilwamala Thiruvananthapuram  
Pin. 680 597 Kerala

NEHRU COLLEGE OF ENGINEERING AND RESEARCH CENTRE

MCA DEPARTMENT 2015 - 2016

ATTENDANCE TEAM A

16<sup>th</sup> - 27<sup>th</sup> Nov 2015

NO.	NAME	16	17	18	19	20	23	24	25	26	27
1	ABDUL BASITH	/	/	/	/	/	/	/	/	/	/
2	AMBIKA P	/	/	/	/	/	/	a	a	/	/
3	AMRUTHA SANKARANARAYANAN	/	/	a	/	/	/	/	/	/	/
4	ANJU S	/	/	/	/	a	/	/	/	/	/
5	CHINJU SHAJI	/	/	/	/	/	/	/	/	a	/
6	DHEERAJ DAS	/	a	/	/	/	/	/	/	/	/
7	DIVYA P M	/	/	/	/	/	/	/	/	/	/
8	FAIDAH BEEVI A T	/	/	/	/	/	/	/	/	/	/
9	JIJI KRISHNA P R	/	/	/	/	/	/	/	/	/	/
10	JOTHI I	/	/	/	/	/	/	/	/	/	/
11	MUHAMMED FIROZ	/	/	/	/	/	/	/	/	/	/
12	NAVANEETH KRISHNAN P	/	/	/	/	/	/	a	/	/	/
13	PAVITHRA K	/	/	/	/	/	/	/	a	/	/
14	RAMEEZ M	/	/	/	a	/	/	/	/	/	/
15	RESHMA M	/	/	/	/	/	/	/	/	/	/
16	SAJIN C P	/	/	/	/	/	/	/	/	a	/
17	SONY K.	/	/	/	/	/	/	/	/	/	/
18	SREENATH T M	/	/	/	/	/	a	/	/	/	/
19	SUNIL V	/	/	/	/	/	a	a	/	/	/
20	VISHNU M	/	/	/	/	/	/	/	/	/	/
21	AISWARYA K	/	/	/	/	/	/	/	/	/	/
22	AISWARYA R	/	/	/	/	a	/	/	/	a	/
23	AMAL N P	/	/	/	/	/	a	a	/	/	/
24	ANJU K	/	/	/	/	/	/	/	/	/	/
25	ANJU S	/	/	/	/	/	/	/	/	/	/
26	ANNAPOORNI K G	/	/	/	a	a	/	/	/	/	/
27	ANUMOL ANTONY	/	/	/	/	/	/	/	/	/	/
28	ANUWATHI.V.	/	/	/	/	a	/	/	/	/	/

PRINCIPAL  
Nehru College of  
Engineering and Research Centre  
Anapady Thiruvipamala Thiruvananthapuram  
Pin 686 597 Kerala

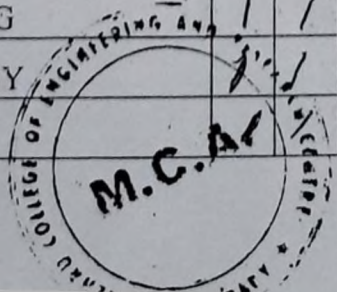
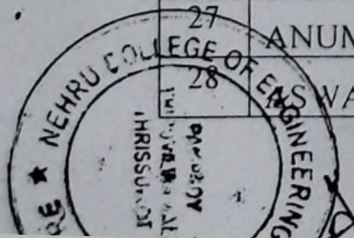

*Handwritten signature*

29	MOHAMMED RAOFAL	/	/	/	/	a	/	/	/	/	/
30	NAMITHA P S	/	/	/	/	a	/	/	/	/	/
31	NANCY KOCHOUSEPH	/	/	/	/	/	/	/	/	/	/
32	NEELIMA M P	/	/	/	/	/	/	/	/	/	/
33	NIDHILA K	/	/	/	/	/	/	/	/	/	/
34	PRESSY MATHEW	/	/	/	/	/	/	/	/	/	/
35	RAIBY M BENNY	/	/	/	/	/	/	/	/	/	/
36	SHAMILA M I	/	/	/	/	/	/	/	/	/	/
37	SHOBICA KAILAS S	/	/	/	/	/	/	/	/	/	/
38	SNEHA MOHAN P	/	/	/	/	/	/	/	/	/	/
39	SREEJITH K	/	/	/	/	/	/	/	/	/	/
40	SUBAIR A S	/	/	/	/	/	/	/	/	/	/
41	SUMI M	/	/	/	/	/	/	/	/	/	/

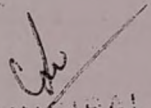

  
 PRINCIPAL  
 Nehru College of  
 Engineering and Research Centre  
 Panipady Thiruvilwamala, Thiruvananthapuram Dt  
 Pin - 680 597 Kerala

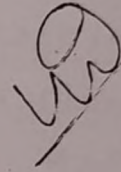

# NEHRU COLLEGE OF ENGINEERING AND RESEARCH CENTRE

MCA DEPARTMENT 2015 - 2016

## ATTENDANCE TEAM B

16<sup>th</sup> - 27<sup>th</sup> Nov 2015

NO.	NAME	16	17	18	19	20	23	24	25	26	27
1	NAIR ANISHA BALAKRISHNAN	/	/	/	/	/	/	/	/	/	/
2	NEERAJ KRISHNAN P	/	/	/	/	a	/	/	/	/	/
3	NEON K K	/	/	/	/	/	/	/	/	/	/
4	NIJEESH P R	/	/	a	/	/	/	/	/	/	/
5	PREETHI K	/	/	/	/	/	/	/	/	/	/
6	PRIYANKA RAJ S	/	/	/	/	a	/	/	/	/	/
7	REVATHY T C	/	/	/	/	/	/	/	/	/	/
8	SHAMEEMA K P	/	/	/	/	a	/	/	/	/	/
9	SHEEBA A	/	/	/	/	/	/	/	/	/	/
10	SHILPA RAMESH P	/	/	/	/	/	/	/	/	/	/
11	SMINUMOL E S	/	/	/	/	/	/	/	/	/	/
12	SOMYA N	/	/	/	/	/	/	a	/	/	/
13	SONI K	/	/	/	/	/	/	/	/	/	/
14	SUDHISHMA T	/	/	/	/	/	/	/	/	/	/
15	VIBITHA C	/	/	/	/	/	/	/	/	/	/
16	VISHAL P V	/	/	/	/	/	/	/	/	/	/
17	AISWARYA K R	/	/	/	/	/	/	/	/	/	/
18	AJESH A J	/	/	/	/	/	/	/	/	/	/
19	ASHA JOHNY	/	/	/	/	/	/	/	/	/	/
20	ASHITHA B Y	/	/	/	/	/	/	/	/	/	/
21	ATHIRA O M	/	/	/	/	/	/	/	/	/	/
22	BINDHU BALACHANDRAN	/	/	/	/	/	/	a	/	/	/
23	DEVI KRISHNA P R	/	/	/	/	/	/	/	/	/	/
24	DIPIN K S	/	/	/	/	/	/	/	/	/	/
25	DIVYA K	/	/	a	/	/	/	/	/	/	/
26	FAYIS K T	/	/	a	/	/	/	/	/	/	/
27	JAYASREE P	/	/	/	/	/	/	/	/	/	/
28	IBIN VARGHESE	/	/	/	/	/	/	/	/	/	/

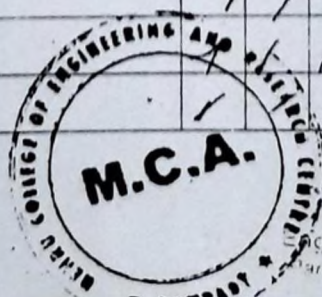
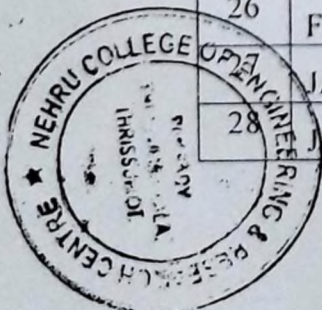

PRINCIPAL  
Nehru College of  
Engineering and Research Cent  
Thiruvananthapuram  
Pin - 695001

29	DIVYA P	/	/	/	/	/	/	/	/	/
30	GANESH NARAYANAN	/	/	a	/	/	/	/	/	/
31	HIMA S	/	a	/	a	/	/	/	/	/
32	HONEY XAVIER	/	a	/	/	/	/	/	/	/
33	JISHA P J	/	/	/	/	/	/	/	/	/
34	JITHU POUL	/	/	/	/	/	/	/	/	/
35	KEERTHY A R	/	/	/	/	/	/	/	/	/
36	KRISHNA PRIYA. S.	/	/	/	a	/	/	/	/	/
37	KRISHNA SHARMA K	/	/	/	/	/	/	/	/	/
38	LAKSHMIDEVI M V	/	/	/	/	/	/	/	/	/
39	MANSOOR E	/	/	/	/	/	/	/	/	/
40	MANU KRISHNAN K	/	/	/	/	/	/	/	/	/
41	MEERADEVI M	/	/	/	/	/	/	/	/	/

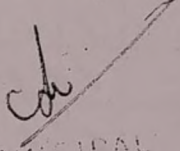

  
 PRINCIPAL  
 Nehru College of  
 Engineering and Research Centre  
 Pampady Thiruvithanur, Thiruvananthapuram Dt  
 Pin 680 597 Kerala



NEHRU COLLEGE OF ENGINEERING AND RESEARCH CENTRE

DEPARTMENT OF MCA

Web Designing Question Paper

Each question carries 1 mark

1. What does CSS stand for?
  - A. Creative Style Sheets
  - B. Colorful Style Sheets
  - C. Cascading Style Sheets
  - D. Computer Style Sheets
  
2. What is the correct HTML for referring to an external style sheet?
  - A. `<stylesheet>mystyle.css</stylesheet />`
  - B. `<style src="mystyle.css" />`
  - C. `<link rel="stylesheet" type="text/css" href="mystyle.css">`
  
3. Where in an HTML document is the correct place to refer to an external style sheet?
  - A. At the end of the document
  - B. In the <head> section
  - C. At the top of the document
  - D. In the <body> section
  
4. Which HTML tag is used to define an internal style sheet?
  - A. `<style>`
  - B. `<css>`
  - C. `<script>`
  
5. Which HTML attribute is used to define inline styles?
  - A. font
  - B. class
  - C. styles
  - D. style
  
6. Which is the correct CSS syntax?
  - A. `body {color: black}`
  - B. `{body;color:black}`
  - C. `{body:color=black(body)}`
  - D. `body;color=black`
  
7. How do you insert a comment in a CSS file?
  - A. `// this is a comment //`
  - B. `/* this is a comment */`
  - C. `' this is a comment`
  - D. `// this is a comment`
  
8. Which property is used to change the background color?
  - A. bgcolor:
  - B. background-color:
  - C. color:

Ans: background-color;

9. How do you add a background color for all <h1> elements?



**PRINCIPAL**  
Nehru College of  
Engineering and Research Centre  
Campady, Thiruvilwamala, Thiruvananthapuram  
Pin 680 597 Kerala

- A. `all.h1 {background-color:#FFFFFF}`  
B. `h1.all {background-color:#FFFFFF}`  
C. `h1 {background-color:#FFFFFF}`
10. How do you change the text color of an element?  
A. `text-color=`  
B. `fgcolor:`  
C. `color:`  
D. `text-color:`
11. Which CSS property controls the text size?  
A. `font-size`  
B. `font-style`  
C. `text-style`  
D. `text-size`
12. What is the correct CSS syntax for making all the <p> elements bold?  
A. `<p style="text-size:bold">`  
B. `p {font-weight:bold}`  
C. `p {text-size:bold}`  
D. `<p style="font-size:bold">`
13. How do you display hyperlinks without an underline?  
A. `a {text-decoration:no underline}`  
B. `a {decoration:no underline}`  
C. `a {text-decoration:none}`  
D. `a {underline:none}`
14. How do you make each word in a text start with a capital letter?  
A. `text-transform:capitalize`  
B. You can't do that with CSS  
C. `text-transform:uppercase`
15. How do you change the font of an element?  
A. `font-family:`  
B. `font=`  
C. `f:`
16. How do you make the text bold?  
A. `font:b`  
B. `font-weight:bold`  
C. `style:bold`
17. How do you display a border like this:  
The top border = 10 pixels  
The bottom border = 5 pixels  
The left border = 20 pixels  
The right border = 1pixel?  
A. `border-width:10px 20px 5px 1px`  
B. `border-width:10px 1px 5px 20px`  
C. `border-width:5px 20px 10px 1px`  
D. `border-width:10px 5px 20px 1px`

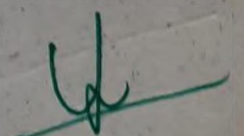

  
PRINCIPAL  
Nehru College of  
Research Cent

8. How do you change the left margin of an element?

- A. margin:
- B. indent:
- C. margin-left:
- D. text-indent:

Ans: C

19. To define the space between the element's border and content, you use the padding property, but are you allowed to use negative values?

- A. Yes
- B. No

20. How do you make a list that lists its items with squares?

- A. list-type: square
- B. type: square
- C. type: 2
- D. list-style-type: square

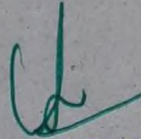
  
**PRINCIPAL**  
Nehru College of  
Engineering and Research Centre  
Pampady, Thiruvilwamala, Thrissur Dt  
Pin 680 597 Kerala



Web Designing

1. A webpage displays a picture. What tag was used to display that picture?

- a. picture
- b. image
- c. img
- d. src

2. <b> tag makes the enclosed text bold. What is other tag to make text bold?

- a. <strong>
- b. <dar>
- c. <black>
- d. <emp>

3. Tags and text that are not directly displayed on the page are written in \_\_\_\_\_ section.

- a. <html>
- b. <head>
- c. <title>
- d. <body>

4. Which tag inserts a line horizontally on your web page?

- a. <hr>
- b. <line>
- c. <line direction="horizontal">
- d. <tr>

5. What should be the first tag in any HTML document?

- a. <head>
- b. <title>
- c. <html>
- d. <document>

6. Which tag allows you to add a row in a table?

- a. <td> and </td>
- b. <cr> and </cr>
- c. <th> and </th>
- d. <tr> and </tr>

7. How can you make a bulleted list?

- a. <list>
- b. <nl>
- c. <ul>
- d. <ol>

8. How can you make a numbered list?

- a. <dl>

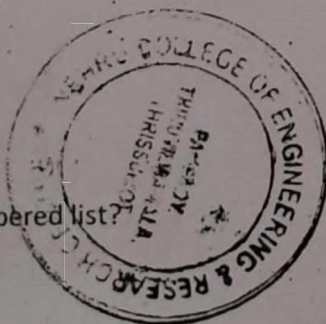

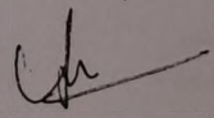
  
PRINCIPAL  
Nehru College of  
Engineering and Research Centre  
Panipady Thiruvikramala Thiruvananthapuram  
Pin 680 597 Kerala

<ol>  
<list>  
<ul>

How can you make an e-mail link?

- a. <a href="xxx@yyy ">
- b. <mail href="xxx@yyy ">
- c. <mail>xxx@yyy </mail>
- d. <a href="mailto:xxx@yyy ">

10. What is the correct HTML for making a hyperlink?

- a. <a href="http:// mcqsets.com">ICT Trends Quiz</a>
- b. <a name="https://mcqsets.com">ICT Trends Quiz</a>
- c. <https://mcqsets.com</a>
- d. url="https://mcqsets.com">ICT Trends Quiz

11. Choose the correct HTML tag to make a text italic

- a. <ii>
- b. <italics>
- c. <italic>
- d. <i>

12. Choose the correct HTML tag to make a text bold?

- a. <b>
- b. <bold>
- c. <bb>
- d. <bld>

13. What is the correct HTML for adding a background color?

- a. <body color="yellow">
- b. <body bgcolor="yellow">
- c. <background>yellow</background>
- d. <body background="yellow">

14. Choose the correct HTML tag for the smallest size heading?

- a. <heading>
- b. <h6>
- c. <h1>
- d. <head>

15. What is the correct HTML tag for inserting a line break?

- a. <br>
- b. <lb>
- c. <break>
- d. <newline>

16. What does vlink attribute mean?

- a. visited link
- b. virtual link

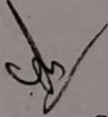

  
PRINCIPAL  
Nehru College of  
Engineering and Research Centre  
Pattipady Thiruvithamoor Palakkad Dt  
Pin 680 597 Kerala

- c. very good link
- d. active link

17. Which attribute is used to name an element uniquely?

- a. class
- b. id
- c. dot
- d. all of above

18. Which tag creates a check box for a form in HTML?

- a. <checkbox>
- b. <input type="checkbox">
- c. <input=checkbox>
- d. <input checkbox>

19. To create a combo box (drop down box) which tag will you use?

- a. <select>
- b. <list>
- c. <input type="dropdown">
- d. all of above

20. Which of the following is not a pair tag?

- a. <p>
- b. <u >
- c. <i>
- d. <img>

21. To create HTML document you require a

- a. web page editing software
- b. High powered computer
- c. Just a notepad can be used
- d. None of above

22. The special formatting codes in HTML document used to present content are

- a. tags
- b. attributes
- c. values
- d. None of above

23. HTML documents are saved in

- a. Special binary format
- b. Machine language codes
- c. ASCII text
- d. None of above

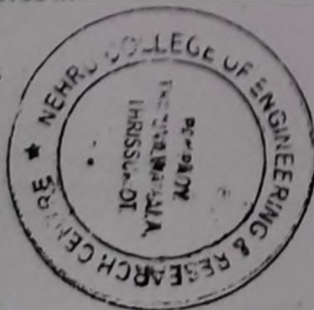

PRINCIPAL

Nehru College of  
Engineering and Research Centre  
Pampady Thiruvilwamala Thiruvananthapuram  
Pin 680 597 Kerala

24. Some tags enclose the text. Those tags are known as

- a. Couple tags
- b. Single tags
- c. Double tags
- d. Pair tags

25. The \_\_\_\_ character tells browsers to stop tagging the text

- a. ?
- b. /
- c. >
- d. %

Q. Can I download the MCQ banks in MCQSets.com?

- a. Yes, do a search in mcqsets.com site
- b. Yes, some files are offered to download free
- c. mcqsets.com has download sections
- d. The downloads are available as PDF files

26. In HTML document the tags

- a. Should be written in upper case
- b. should be written in lower case
- c. should be written in propercase
- d. can be written in both uppercase or lowercase

27. Marquee is a tag in HTML to

- a. mark the list of items to maintain in queue
- b. Mark the text so that it is hidden in browser
- c. Display text with scrolling effect
- d. None of above

28. There are \_\_\_\_ different of heading tags in HTML

- a. 4
- b. 5
- c. 6
- d. 7

29. To create a blank line in your web page

- a. press Enter two times
- b. press Shift + Enter
- c. insert <BR> tag
- d. insert <BLINE>

30. Which of the following is not a style tag?

- a. <b>
- b. <tt>
- c. <i>
- d. All of above are style tags

31. The way the browser displays the object can be modified by \_\_\_\_

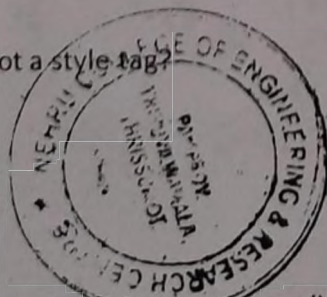

*Handwritten signature*

PRINCIPAL  
Nehru College of  
Engineering & Research Centre  
Pampady, Thiruvananthapuram Dt  
Pin - 680 597 Kerala

- a. attributes
- b. parameters
- c. modifiers
- d. None of above

32. Which of the following HTML code is valid?

- a. <font colour="red">
- b. <font color="red">
- c. <red><font>
- d. All of above are style tags

33. Which of the following is an attribute related to font tag?

- a. size
- b. face
- c. color
- d. All of above are style tags

34. HTML supports

- a. ordered lists
- b. unordered lists
- c. both type of lists
- d. does not support those types

35. What tag is used to list individual items of an ordered list?

- a. LI
- b. OL
- c. UL
- d. None of above

36. When should you use path along with file name of picture in IMG tag?

- a. path is optional and not necessary
- b. when the location of image file and html file are different
- c. when image file and html file both are on same location
- d. path is always necessary when inserting image

37. Which of the following is not a valid alignment attribute?

- a. Left
- b. Right
- c. Top
- d. All of above

38. Which attribute is used withing tag to display the text if image could not load in browser?

- a. description
- b. name
- c. alt
- d. id

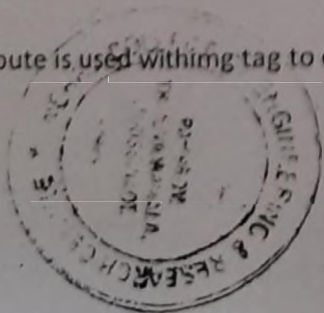

39. Which attribute can be used with BODY tag to set background color green?

- a. background="green"
- b. bgcolor="green"
- c. vlink="green"
- d. None of above

40. Which attribute you'll use with TD tag to merge two cells horizontally?

- a. merge=colspan2
- b. rowspan=2
- c. colspan=2
- d. merge=row2

41. A webpage displays a picture. What tag was used to display that picture?

- a. picture
- b. mage
- c. img
- d. src

42. <b> tag makes the enclosed text bold. What is other tag to make text bold?

- a. <strong>
- b. <dar>
- c. <black>
- d. <emp>

43. Tags and text that are not directly displayed on the page are written in \_\_\_\_\_ section.

- a. <html>
- b. <head>
- c. <title>
- d. <body>

44. Which tag inserts a line horizontally on your web page?

- a. <hr>
- b. <line>
- c. <line direction="horizontal">
- d. <tr>

45. What should be the first tag in any HTML document?

- a. <head>
- b. <title>
- c. <html>
- d. <document>

46. Which tag allows you to add a row in a table?

- a. <td> and </td>
- b. <tr> and </tr>
- c. <tbody> and </tbody>
- d. <table> and </table>

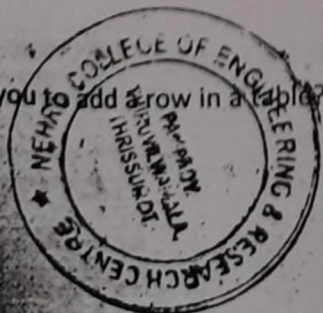

PRINCIPAL  
Nehru College of  
Engineering and Research Centre  
Panapady, Thiruvilwamala, Thr. Dt  
Pin 680 597 K

47. How can you make a bulleted list?

- a. <list>
- b. <nl>
- c. <ul>
- d. <ol>

48. How can you make a numbered list?

- a. <dl>
- b. <ol>
- c. <list>
- d. <ul>

49. How can you make an e-mail link?

- a. <a href="xxx@yyy ">
- b. <mail href="xxx@yyy ">
- c. <mail>xxx@yyy </mail>
- d. <a href="mailto:xxx@yyy ">

50. What is the correct HTML for making a hyperlink?

- a. <a href="http://mcqsets.com">MCQ Sets Quiz</a>
- b. <a name="http://mcqsets.com">MCQ Sets Quiz</a>
- c. <http://mcqsets.com</a>
- d. url="http://mcqsets.com">MCQ Sets Quiz

51. Choose the correct HTML tag to make a text italic

- a. <ii>
- b. <italics>
- c. <italic>
- d. <i>

Q. Can I download the MCQ banks in MCQSets.com?

- a. Yes, do a search in mcqsets.com site
- b. Yes, some files are offered to download free
- c. mcqsets.com has download sections
- d. The downloads are available as PDF files

52. Choose the correct HTML tag to make a text bold?

- a. <b>
- b. <bold>
- c. <bb>
- d. <bld>

53. What is the correct HTML for adding a background color?

- a. <body color="yellow">
- b. <body bgcolor="yellow">
- c. <background>yellow</background>



*Cal*

PRINCIPAL

Nehru College of  
Engineering and Research Center  
Panipady, Thiruvananthapuram, Kerala  
Pin - 695 027 Kerala

d. <body background="yellow">

54. Choose the correct HTML tag for the smallest size heading?

- a. <heading>
- b. <h6>
- c. <h1>
- d. <head>

Visit <https://mcqsets.com> for more MCQ Banks, answers to the subjective questions, online quiz and much more!

55. What is the correct HTML tag for inserting a line break?

- a. <br>
- b. <lb>
- c. <break>
- d. <newline>

56. What does vlink attribute mean?

- a. visited link
- b. virtual link
- c. very good link
- d. active link

57. Which attribute is used to name an element uniquely?

- a. class
- b. d
- c. dot
- d. all of above

58. Which tag creates a check box for a form in HTML?

- a. <checkbox>
- b. <input type="checkbox">
- c. <input=checkbox>
- d. <input checkbox>

59. To create a combo box (drop down box) which tag will you use?

- a. <select>
- b. <list>
- c. <input type="dropdown">
- d. all of above

60. Which of the following is not a pair tag?

- a. <p>
- b. <u>
- c. <i>
- d. <img>

61. What is the full form of HTML?

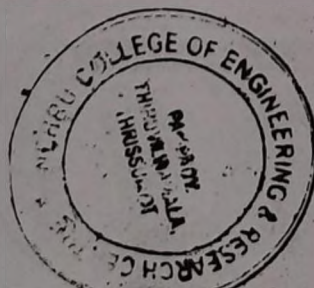

PRINCIPAL  
Nehru College of  
Engineering and Research Centre  
Panipady, Thiruvananthapuram, Kerala Dt.  
Pin - 690 597, Kerala

- a. Hyper text markup language
- b. Hyphenation text markup language
- c. Hyphenation test marking language
- d. Hyper text marking language

62. What is the full form of HTTP?

- a. Hyper text transfer protocol
- b. Hyper text transfer package
- c. Hyphenation text test program
- d. none of the above

63. What is a search engine?

- a. a program that searches engines
- b. a web site that searches anything
- c. a hardware component
- d. a machinery engine that search data

64. What is the full form of TCP/IP?

- a. transmission control protocol / internet protocol
- b. telephone call protocol / international protocol
- c. transport control protocol / internet protocol
- d. none of the above

65. HTML document start and end with which tag pairs?

- a. <HEAD>.....</HEAD>
- b. <BODY>.....</BODY>
- c. <HTML>.....</HTML>
- d. <WEB>.....</WEB>

Visit <https://mcqsets.com> for more MCQ Banks, answers to the subjective questions, online quiz and much more!

66. Which tag is used to create body text in HTML?

- a. <HEAD>
- b. <TEXT>
- c. <TITLE>
- d. <BODY>

67. "Yahoo", "Infoseek" and "Lycos" are \_\_\_\_\_?

- a. Search Engines
- b. Browsers
- c. News groups
- d. None of the above

68. What does the .com domain represents?

- a. Education domain
- b. Commercial domain
- c. Network
- d. None of the above

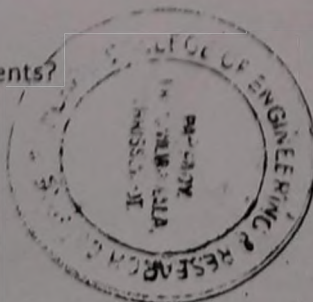

*Handwritten signature*  
PRINCIPAL  
Anna College of  
Engineering and Research Center  
Palangy Thiruvananthapuram  
Pin 680 597 Kerala

69. In Satellite based communication, VSAT stands for?

- a. Very Small Aperture Terminal
- b. Varying Size Aperture Terminal
- c. Very Small Analog Terminal
- d. None of the above

70. Outlook Express is a \_\_\_\_\_

- a. E-Mail Client
- b. Browser
- c. SearchEngine
- d. None of the above

71. <TITLE> ... </TITLE> tag must be within \_\_\_\_\_

- a. Title
- b. Form
- c. Header
- d. Body

72. Text within <EM> ... </EM> tag is displayed as \_\_\_\_\_

- a. bold
- b. italic
- c. list
- d. indented

73. Text within <STRONG> ... </STRONG> tag is displayed as \_\_\_\_\_

- a. bold
- b. italic
- c. list

d. indented

74. <UL> ... </UL> tag is used to \_\_\_\_\_

- a. display the numbered list
- b. underline the text
- c. display the bulleted list
- d. bold the text

75. Which tag is used to display the numbered list?

- a. <OL></OL>
- b. <DL></DL>
- c. <UL></UL>
- d. <LI></LI>

76. Which tag is used to display the large font size?

- a. <LARGE></LARGE>

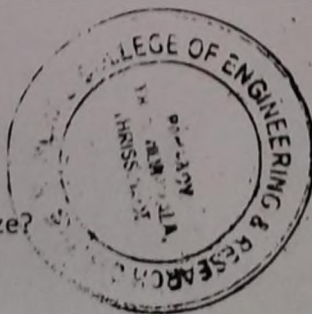

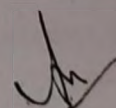
  
PRINCIPAL  
Nehru College of  
Engineering and Research Centre  
Panipady Thiruvilwakkudi, Tamil Nadu  
Pin 680 557

- b. <BIG></BIG>
- c. < SIZE ></SIZE>
- d. <FONT></FONT>

77. <SCRIPT> ... </SCRIPT> tag can be placed within \_\_\_\_\_

- a. Header
- b. Body
- c. both A and B
- d. none of the above

78. using <P> tag will

- a. start a new paragraph
- b. break the line
- c. end the current paragraph
- d. none of the above

79. <TD> ... </TD> tag is used for \_\_\_\_\_

- a. Table heading
- b. Table Records
- c. Table row
- d. none of the above

80. Which is true to change the text color to red?

- a. <BODY BGCOLOR=RED>
- b. <BODY TEXT=RED>
- c. <BODY COLOR=RED>
- d. none of the above

81. With regards to e-mail addresses:

- a. they must always contain an @ symbol
- b. they can never contain spaces
- c. they are case-insensitive
- d. all of the above

82. A homepage is \_\_\_\_\_

- a. an index of encyclopedia articles
- b. where all Internet data is stored
- c. required for access to the Internet
- d. the first page of a website

83. Which of the following is used to explore the Internet?

- a. Browser
- b. Spreadsheet
- c. Clipboard
- d. Draw

Q. You can use mcqSets.com for

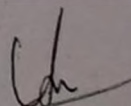

  
PRINCIPAL  
Nehru College of  
Engineering and Research Centre  
Panipady, Thiruvananthapuram, Kerala  
Pin - 580 507 Kerala

- 1. Online quiz
- 2. Downloads

34. What is Internet Explorer?

- a. An Icon
- b. A File Manager
- c. A Browser
- d. The Internet

85. What do I need to get onto the Internet?

- a. Computer
- b. Modem
- c. Browser
- d. All of the above

86. What is an ISP?

- a. nternet System Protocol
- b. nternal System Program
- c. Internet Service Provider
- d. None of the above

87. Which of the following is valid IP address?

- a. 984.12.787.76
- b. 192.168.321.10
- c. 1.888.234.3456
- d. 192.168.56.115

88. Which is not a domain name extension

- a. mil
- b. org
- c. .int
- d. .com

89. What is a FTP program used for?

- a. Transfer files to and from an Internet Server
- b. Designing a website
- c. Connecting to the internet
- d. None of the above

90. Which of the following are commonly found on web pages?

- a. nternet
- b. hyperlinks
- c. intranet
- d. all of the above

91. What is the correct syntax in HTML for creating a link on a webpage?

- a. <LINK SRC= "mcqsets.html">

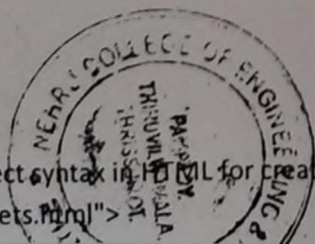

PRINCIPAL  
Nehru College of  
Engineering and Research Centre  
Paripady Thiruvananthapuram, Kerala Dt

- b. <BODY LINK = "mcqsets.html">
- c. <A SRC = "mcqsets.html" >
- d. <A HREF = "mcqsets.html">

92. Which of the following is an attribute of <Table> tag?

- a. SRC
- b. LINK
- c. CELLPADDING
- d. BOLD

93. Choose the correct HTML tag to make the text bold?

- a. <B>
- b. <BOLD>
- c. <STRONG>
- d. Both A) and C)

94. Which HTML tag would be used to display power in expression  $(A+B)^2$  ?

- a. <SUP>
- b. <SUB>
- c. <B>
- d. <P>

Q. You can use mcqsets.com for

- a. Online quiz
- b. MCQ Banks
- c. Downloads
- d. Subjective Questions & answers

Visit <https://mcqsets.com>

95. Choose the correct HTML code to create an email link?

- a. <A HREF = "admin@mcqsets.com "></A>
- b. <A HREF = "mailto:suresh@mcqsets.com"></A>
- c. <MAIL>admin@mcqsets.com </MAIL>
- d. MAILHREF = "[email protected] ">

96. Choose the correct HTML tag for the largest heading?

- a. <H1>
- b. <H6>
- c. <H10>
- d. <HEAD>

97. Output of XML document can be viewed in a

- a. Word Processor
- b. Web browser
- c. Notepad
- d. None of the above

98. What is the correct way of describing XML data?

- a. XML uses a DTD to describe data

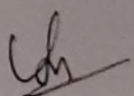

  
PRINCIPAL  
Nehru College of  
Engineering and Research Cen  
Pampady Thiruvananthapuram  
Pin 680 597 Kerala

- b. XML uses a description node to describe data
- c. XML uses XSL to describe the data
- d. XML uses a validator to describe the data

99. Comments in XML document is given by:

- a. <!-- -->
- b. <!-- --!>
- c. <!-- -->
- d. </-- -->

100. Which statement is true?

- a. An XML document can have one root element
- b. An XML document can have one child element
- c. XML elements have to be in lowercase
- d. All of the above

- |        |        |        |        |        |        |        |        |        |         |
|--------|--------|--------|--------|--------|--------|--------|--------|--------|---------|
| 1 - c  | 2 - a  | 3 - b  | 4 - a  | 5 - c  | 6 - d  | 7 - c  | 8 - b  | 9 - d  | 10 - a  |
| 11 - d | 12 - a | 13 - b | 14 - b | 15 - a | 16 - a | 17 - b | 18 - b | 19 - a | 20 - d  |
| 21 - c | 22 - a | 23 - c | 24 - d | 25 - b | 26 - d | 27 - c | 28 - c | 29 - c | 30 - d  |
| 31 - a | 32 - b | 33 - d | 34 - c | 35 - a | 36 - b | 37 - c | 38 - c | 39 - b | 40 - c  |
| 41 - c | 42 - a | 43 - b | 44 - a | 45 - c | 46 - d | 47 - c | 48 - b | 49 - d | 50 - a  |
| 51 - d | 52 - a | 53 - b | 54 - b | 55 - a | 56 - a | 57 - b | 58 - b | 59 - a | 60 - d  |
| 61 - a | 62 - a | 63 - b | 64 - a | 65 - c | 66 - d | 67 - a | 68 - b | 69 - a | 70 - a  |
| 71 - c | 72 - b | 73 - a | 74 - c | 75 - a | 76 - b | 77 - c | 78 - a | 79 - b | 80 - b  |
| 81 - d | 82 - d | 83 - a | 84 - c | 85 - d | 86 - c | 87 - d | 88 - c | 89 - a | 90 - b  |
| 91 - d | 92 - c | 93 - d | 94 - a | 95 - b | 96 - a | 97 - b | 98 - c | 99 - c | 100 - a |

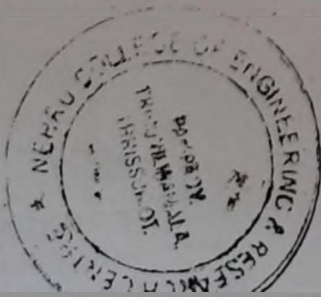

*[Handwritten Signature]*

PRINCIPAL  
 NERU College of  
 Engineering and Research Centre  
 Pampady Thruvankulam Thiruvananthapuram Dt  
 Pin 680 597 Kerala

Nijesh P R  
MCA

NEHRU COLLEGE OF ENGINEERING AND RESEARCH CENTRE

DEPARTMENT OF MCA

Web Designing Question Paper

Each question carries 1 mark

1. What does CSS stand for?  
A. Creative Style Sheets  
B. Colorful Style Sheets  
 C. Cascading Style Sheets  
D. Computer Style Sheets
2. What is the correct HTML for referring to an external style sheet?  
A. <stylesheet>mystyle.css</stylesheet />  
B. <style src="mystyle.css" />  
 C. <link rel="stylesheet" type="text/css" href="mystyle.css">
3. Where in an HTML document is the correct place to refer to an external style sheet?  
A. At the end of the document  
 B. In the <head> section  
C. At the top of the document  
D. In the <body> section
4. Which HTML tag is used to define an internal style sheet?  
 A. <style>  
B. <css>  
C. <script>
5. Which HTML attribute is used to define inline styles?  
A. font  
B. class  
C. styles  
 D. style
6. Which is the correct CSS syntax?  
 A. body {color: black}  
B. {body;color:black}  
C. {body:color=black(body)}  
D. body:color=black
7. How do you insert a comment in a CSS file?  
A. // this is a comment //  
 B. /\* this is a comment \*/  
C. ' this is a comment  
D. // this is a comment
8. Which property is used to change the background color?  
A. bgcolor:  
 B. background-color:  
C. color:
9. How do you add a background color for all <h1> elements?



  
PRINCIPAL  
Nehru College of  
Engineering and Research Centre  
Pampady Thiruvikramala Thrissur Dt  
Pin 680 597 Kerala



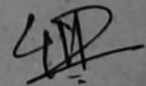

- A. all.h1 {background-color:#FFFFFF}
- B. h1.all {background-color:#FFFFFF}
- C. h1 {background-color:#FFFFFF}
10. How do you change the text color of an element?
- A. text-color=
- B. fgcolor:
- C. color:
- D. text-color:
11. Which CSS property controls the text size?
- A. font-size
- B. font-style
- C. text-style
- D. text-size
12. What is the correct CSS syntax for making all the <p> elements bold?
- A. <p style="text-size:bold">
- B. p {font-weight:bold}
- C. p {text-size:bold}
- D. <p style="font-size:bold">
13. How do you display hyperlinks without an underline?
- A. a {text-decoration:no underline}
- B. a {decoration:no underline}
- C. a {text-decoration:none}
- D. a {underline:none}
14. How do you make each word in a text start with a capital letter?
- A. text-transform:capitalize
- B. You can't do that with CSS
- C. text-transform:uppercase
15. How do you change the font of an element?
- A. font-family:
- B. font=
- C. f:
16. How do you make the text bold?
- A. font:b
- B. font-weight:bold
- C. style:bold
17. How do you display a border like this:  
 The top border = 10 pixels  
 The bottom border = 5-pixels  
 The left border = 20 pixels  
 The right border = 1pixel?
- A. border-width:10px 20px 5px 1px
- B. border-width:10px 1px 5px 20px
- C. border-width:5px 20px 10px 1px
- D. border-width:10px 5px 20px 1px



**PRINCIPAL**  
 Nehru College of  
 Engineering and Research Centre  
 Paripady Thiruvananthapuram Thiruvananthapuram  
 Pin: Kerala

8. How do you change the left margin of an element?

- A. margin:
- B. indent:
- C. margin-left:
- D. text-indent:

19. To define the space between the element's border and content, you use the padding property, but are you allowed to use negative values?

- A. Yes
- B. No

20. How do you make a list that lists its items with squares?

- A. list-type: square
- B. type: square
- C. type: 2
- D. list-style-type: square

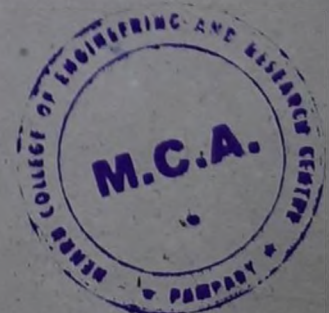
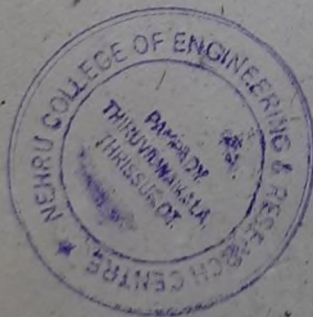

*[Handwritten signature]*

PRINCIPAL  
Nehru College of  
Engineering and Research Centre  
Pampady Thiruvilwamala, Thirissur Dt  
Pin 680597 Kerala

NEHRU COLLEGE OF ENGINEERING AND RESEARCH CENTRE

MCA DEPARTMENT 2015 – 2016

MARK LIST OF STUDENTS

16<sup>th</sup> – 27<sup>th</sup> Nov 2015

No.	Name	Mark
1	ABDUL BASITH	18
2	AMBIKA P	14
3	AMRUTHA SANKARANARAYANAN	14
4	ANJU S	15
5	CHINJU SHAJI	16
6	DHEERAJ DAS	17
7	DIVYA P M	17
8	FAIDAH BEEVI A T	18
9	JIJI KRISHNA P R	18
10	JOTHI I	19
11	MUHAMMED FIROZ	14
12	NAVANEETH KRISHNAN P	15
13	PAVITHRA K	16
14	RAMEEZ M	14
15	RESHMA M	15
16	SAJIN C P	17
17	SONY K.	18
18	SREENATH T M	19
19	SUNIL .V	15
20	VISHNU M	14
21	AISWARYA K	16
22	AISWARYA R	17
23	AMAL N P	14
24	ANJU K	15
25	ANJU S	16
26	ANNAPOORNI K G	18
27	ANUMOL ANTONY	14
28	ASWATHI.V.	15
29	DIVYA P	15
30	GANESH NARAYANAN	16
31	HIMA S	16
32	HONEY XAVIER	14
33	JISHA P J	18
34	JITHU POUL	19
35	KEERTHY A R	17
36	KRISHNA PRIYA. S.	18
37	KRISHNA SHARMA K	19
38	LAKSHMIDEVI M V	17
39	MANSOOR E	19
40	MANU KRISHNAN K	18
41	MEERADEVI M	15
42	NAIR ANISHA BALAKRISHNAN	14
43	NEERAJ KRISHNAN P	15
44	NEON K K	14

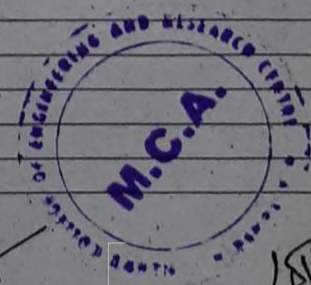
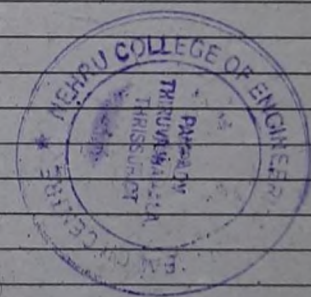

PRINCIPAL

Nehru College of  
Engineering and Research Centre  
Pattipady Thiruvilwamala, Thiruvananthapuram  
Pin 680 597 Kerala

*[Handwritten signature]*

*[Handwritten signature]*

45	NIJEESH P R	17
46	PREETHI K	18
47	PRIYANKA RAJ S	19
48	REVATHY T C	20
49	SHAMEEMA K P	15
50	SHEEBA A	14
51	SHILPA RAMESH P	16
52	SMINUMOL E S	17
53	SOMYA N	18
54	SONI K	18
55	SUDHISHMA T	19
56	VIBITHA C	20
57	VISHAL P V	14
58	AISWARYA K R	15
59	AJESH A J	16
60	ASHA JOHNY	17
61	ASHITHA B Y	18
62	ATHIRA O M	19
63	BINDHU BALACHANDRAN	14
64	DEVI KRISHNA P R	15
65	DIPIN K S	17
66	DIVYA K	18
67	FAYIS K T	19
68	JAYASREE P	20
69	JIBIN VARGHESE	18
70	MOHAMMED RAOFAL	17
71	NAMITHA P S	15
72	NANCY KOCHOUSEPH	16
73	NEELIMA M P	14
74	NIDHILA K	15
75	PRESSY MATHEW	16
76	RAIBY M BENNY	17
77	SHAMILA M I	18
78	SHOBIKA KAILAS S	19
79	SNEHA MOHAN P	17
80	SREEJITH K	18
81	SUBAIR A S	17
82	SUMI M	18



PRINCIPAL

Nehru College of  
Engineering and Research Centre  
Paripady Thiruvilwamala Thirissur Dt  
Pin - 680 597 Kerala

# NEHRU COLLEGE OF ENGINEERING AND RESEARCH CENTRE



NCERC

DEPARTMENT OF MCA

Add-on Program 16th - 27th November 2015

## Certificate of Participation

This is to certify that Mr./Mrs. SOMYA. N ..... of  
NEHRU COLLEGE OF ENGINEERING & RESEARCH CENTRE college has actively participated  
in a value added program "Web Designing". Upon completion of theoretical and  
practical modules and successfully completed the assessment test this document of  
participation is presented.

  
Course Co-ordinator

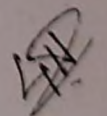
  
HOD-MCA Dept.

  
P  
Ne  
Engineering  
Panipat  
Pin

**Nehru College of  
Engineering and Research Centre**  
Nila Gardens, Pampady, Thiruvilwamala,  
Thrissur 680588.



**DEPARTMENT OF MCA  
Presents**

**Value Added Program  
Web Designing**



**Dates : 16th - 25th November 2015**

**Resource Person: Haris K A**

**Programmer Zyber Solutions**

**Venue : Kapila, NCERC**

**For enquiries contact Coordinator: Mr. Pramod K (9447068556)**



**PRINCIPAL**  
Nehru College of  
Engineering and Research Centre  
Pampady Thiruvilwamala, Thrissur D  
Pin 680 597 Kerala